

# APX2 Non-standby Power Supply

Power



## Installation and Operation Manual

APX2 Non-standby Power Supply

*Effective: April 2006*

Alpha Technologies

Alpha Technologies ®

# Power

---

# APX2

## Non-standby Power Supply

016-526-B0-004, Rev E

Effective Date: April 2006  
Copyright© 2006  
Alpha Technologies, Inc.

A Member of the Alpha Group

 **NOTE:**

---

Photographs contained in this manual are for illustrative purposes only. These photographs may not match your installation

 **NOTE:**

---

Operator is cautioned to review the drawings and illustrations contained in this manual before proceeding. If there are questions regarding the safe operation of this powering system, please contact Alpha Technologies or your nearest Alpha representative.

 **NOTE:**

---

Alpha shall not be held liable for any damage or injury involving its enclosures, power supplies, generators, batteries, or other hardware if used or operated in any manner or subject to any condition not consistent with its intended purpose, or is installed or operated in an unapproved manner, or improperly maintained.

Contacting Alpha Technologies: *www.alpha.com*

or

For general product information and customer service  
(7 AM to 5 PM, Pacific Time), call

**1-800-863-3930,**

For complete technical support, call

**1-800-863-3364**

*7 AM to 5 PM, Pacific Time or 24/7 emergency support*

# Table of Contents

Safety Notes .....	6
1.0 Introduction .....	7
1.1 Operating Principle .....	8
1.2 Standard Features .....	9
1.3 Optional Features .....	10
2.0 Installation.....	12
2.1 Pole-Mount Installations.....	12
2.1.1 Wood Pole Procedure .....	12
2.1.2 Steel or Concrete Pole Procedure.....	13
2.2 Connecting the APX2.....	14
2.2.1 AC Output Connection .....	14
2.2.2 Utility Power Connection .....	15
2.2.3 External Service Disconnect.....	17
2.3 Options.....	19
3.0 Start-Up and Test.....	24
4.0 Troubleshooting and Repair .....	24
4.1 Troubleshooting .....	24
4.2 Repair Instructions .....	24
4.3 Parts and Ordering Information .....	25
4.4 APX2 Schematic / Block Diagram.....	26
5.0 Specifications.....	27

## List of Figures

Fig. 1-1, Ferroresonant ‘Tank’ Circuit and Resulting Output Waveform.....	8
Fig. 1-2, APX2.....	9
Fig. 1-3, APX2 Showing Standard Features.....	9
Fig. 1-4, APX2 and Optional Features.....	10
Fig. 2-1, Mounting Bracket for Wooden Pole.....	12
Fig. 2-2, Mounting Bracket for Steel or Concrete Pole.....	13
Fig. 2-3, Brass Seizure Screw Location.....	14
Fig. 2-4, Center Pin.....	14
Fig. 2-5, Cable Connector / Output Port Assembly.....	14
Fig. 2-6, APX2 Base.....	15
Fig. 2-7, Input Terminal Block.....	15
Fig. 2-8, Service Entrance/Meter Connections 120VAC.....	17
Fig. 2-9, Service Entrance/Meter Connections 240VAC.....	18
Fig. 2-10, Screw Locations for Option Plate.....	19
Fig. 2-11, Input Circuit Breaker Installed in Option Plate.....	20
Fig. 2-12, Input Terminal Block.....	20
Fig. 2-13, Options Connectors.....	21
Fig. 2-14, VSF Output.....	21
Fig. 2-15, Side View of Ammeter.....	22
Fig. 2-16, TDR-M Potentiometer.....	22
Fig. 2-17, SIL-C Installation.....	23
Fig. 4-1, APX2 Schematic.....	26

## List of Tables

Table 1-1, Optional Features.....	11
Table 2-1, Alpha Part Numbers for Square D Breakers.....	16
Table 4-1, Troubleshooting.....	24
Table 4-2, Replacement Parts.....	25
Table 5-1, APX2 Specifications.....	27

# Safety Notes

Review the drawings and illustrations contained in this manual before proceeding. If there are any questions regarding the safe installation or operation of the system, contact Alpha Technologies or the nearest Alpha representative. Save this document for future reference.

To reduce the risk of injury or death, and to ensure the continued safe operation of this product, the following symbols have been placed throughout this manual. Where these symbols appear, use extra care and attention.

## **ATTENTION:**

---

The use of ATTENTION indicates specific regulatory/code requirements that may affect the placement of equipment and installation procedures.



## **NOTE:**

---

A NOTE provides additional information to help complete a specific task or procedure.



## **CAUTION!**

---

The use of CAUTION indicates safety information intended to PREVENT DAMAGE to material or equipment.



## **WARNING!**

---

A WARNING presents safety information to PREVENT INJURY OR DEATH to the technician or user.

# 1.0 Introduction

The Alpha APX2 Non-standby Power Supply provides conditioned power to signal amplifiers in cable television and broadband distribution systems. The transformer is mounted directly to the chassis, and supplies the load with current-limited, regulated AC power that is free from spikes, surges and other forms of power line transients.

AC power enters the module where it is converted to a “quasi” square wave and regulated at the required output voltage. It is then passed on to the load via the VSF fitting located on the baseplate.

The versatile APX2 can be pole or wall-mounted and can be equipped with optional features such as:

- Line and neutral AC input circuit breakers
- Output fuse
- Output receptacle
- Time Delay Relay (TDR-M) to suspend power to the output from 10 to 60 seconds during utility start-up after an AC outage has occurred
- Surge Suppressor (LA-P+ Series) to provide protection from voltage spikes caused by power line disturbances
- Status Indicator LED (SIL-C) to indicate that output power is being supplied to the load
- Amp Clamp (ACAT-3P) to provide “Crowbar” clamping protection from voltage spikes in excess of 104 volts
- Ammeter (AMM) to display output current to the load.

The APX2, along with the entire line of Alpha power products, is one of the most rugged, reliable, and versatile power supplies available. The non-standby power supplies are extremely efficient, and have a typical efficiency rating of 90%.

Alpha Technologies, recognized as an international market leader in the field of backup power, offers complete technical support and prompt, reliable service to ensure that your power supply continues to provide you with years of trouble-free operation.

## 1.0 Introduction, continued

### 1.1 Operating Principle

The basic APX2 unit (without options) contains a ferroresonant transformer, resonant circuit capacitor, VSF output connector, and an input terminal block.

#### Ferroresonant Transformer

Alpha APX2 non-standby power supplies uses ferroresonant transformer technology to provide line conditioning and voltage regulation. The primary and secondary windings of the transformer are physically isolated from each other by a large steel core which significantly reduces the capacitive coupling of spikes and noise to the secondary winding. This provides a regulated, current-limited output with excellent isolation and noise attenuation: 120dB common mode; 60dB transverse mode.

Another unique feature of the ferroresonant transformer is its ability to provide current limiting in the event of a short-circuit. This effect is called foldback. The transformer's output current can typically reach 150% of the nameplate output current rating for a short period of time without damage to the transformer. When the transformer reaches the saturation point, the output current will decrease (foldback on itself) to a minimum value, and thereby provide current limiting.

#### Resonant Circuit Capacitor

An oil-filled resonant AC capacitor is connected to the resonant (secondary) winding of the transformer forming a tank circuit. This provides the resonant circuit function which contributes to the voltage regulation of the supply. The advantage of this type of transformer/capacitor design is the ability of the ferroresonant transformer to regulate its output voltage over a wide range of input voltages and output loading. Typical output voltages may vary  $\pm 3$  to 5%, with input voltage variations of  $\pm 15\%$  of nominal line voltage, and output loading of 20 to 100%. This tight regulation is advantageous in cable television applications as the active devices are protected from dangerous voltage fluctuations.

#### NOTE:

Because the output waveform from the ferroresonant transformer is not a true sine or square wave, but is instead a quasi-square wave, a true RMS voltmeter must be used to correctly measure the output voltages.

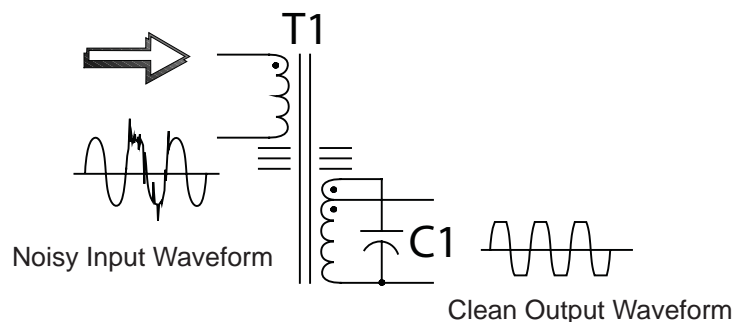

Fig. 1-1, Ferroresonant 'Tank' Circuit and Resulting Output Waveform

## 1.0 Introduction, continued

### 1.2 Standard Features



Fig. 1-2, APX2



Fig. 1-3, APX2 Showing Standard Features

The APX2 non-standby power supply is available in the following configurations:

- **APX2 608 E** (230 VAC, 50 Hz Input) (8 Amp, 480 VA, 60 Volt Output)
- **APX2 614** (120 VAC, 60 Hz Input) (14 Amp, 840 VA, 60 Volt Output)
- **APX2 614 E** (230 VAC, 50 Hz Input) (14 Amp, 840 VA, 60 (48V option) Volt Output)
- **APX2 614 P** (220 VAC, 60 Hz Input) (14 Amp, 840 VA, 60 Volt Output)
- **APX2 915** (120 or 240 VAC, 60 Hz Input) (15 Amp, 1350 VA, 90/75/60 Volt Output)

1.0 Introduction, continued

1.3 Optional Features

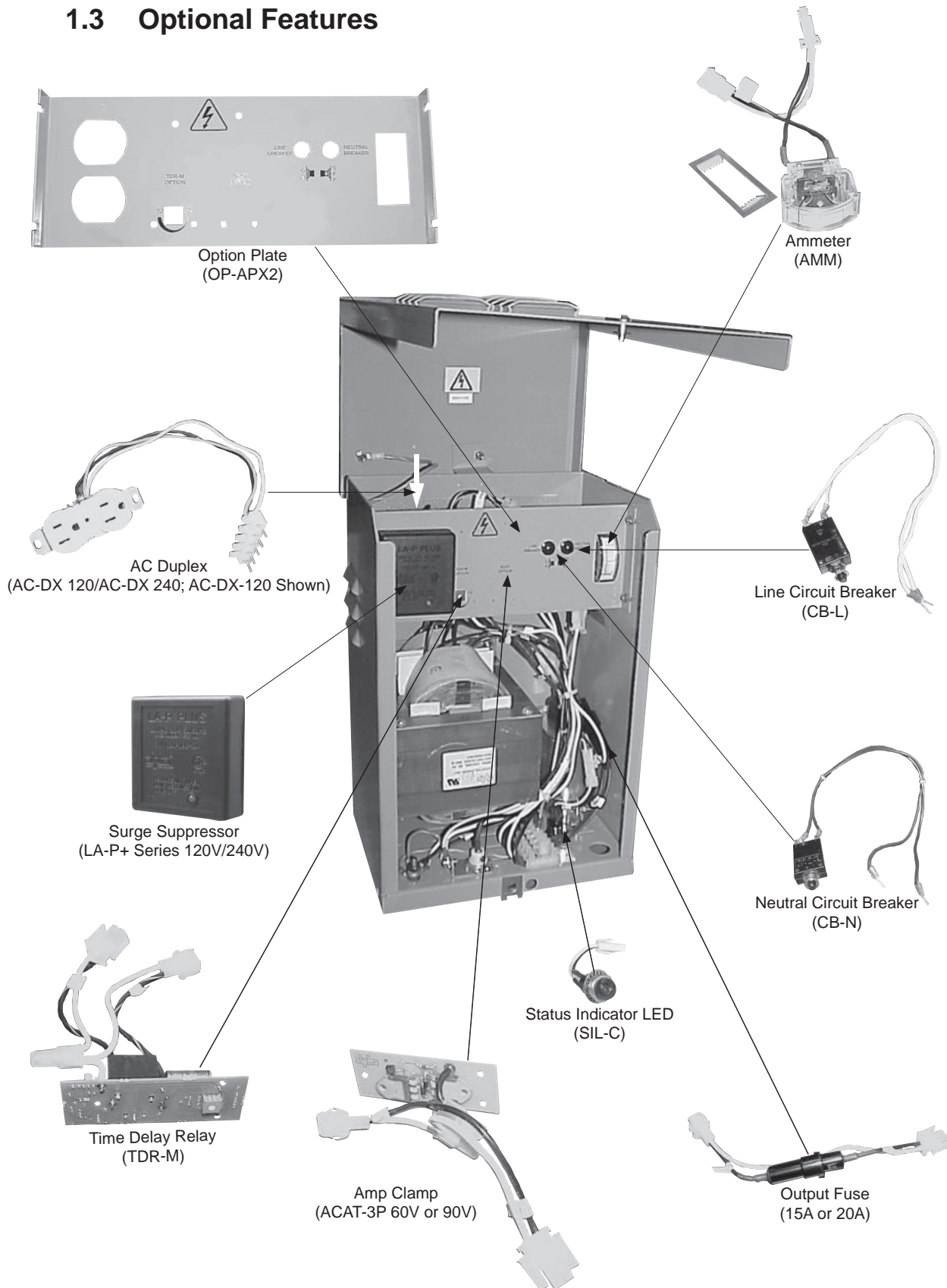

Fig. 1-4, APX2 and Optional Features

## 1.0 Introduction, continued

### 1.3 Optional Features, continued

You can equip the APX2 with the following options:

Option	Description
<b>OP-APX2</b> Option Plate	The option plate provides you with both a user interface and a base on which to install the other options. It is required for all options except the SIL-C and Output Fuse.
<b>CB-L/CB-N</b> Line and Neutral Input Circuit Breakers	The line and neutral input circuit breakers protect the input wiring by limiting the input current to the transformer. In the event the current becomes too high, the breakers will trip.
<b>LAL-P+Series 100-120V/220-240V</b> Plug-in Surge Suppressors	The LA-P+ series surge suppressors are enclosed in a plastic housing and plug directly into a dedicated receptacle. This eliminates the need for additional wiring. This option also provides additional protection from voltage spikes.
<b>AC-DX 120/240</b> AC Duplex	The AC Duplex provides a receptacle position for the LA-P+ Series and serves as an outlet for equipment you may need while servicing the unit, such as light or power tools.
<b>Fuse</b> Output Fuse	The AC Output Fuse protects the load from excessive durations of short circuit current. In the event of such a condition on the output of the transformer, the fuse will blow, protecting the transformer from serious damage.
<b>AMM-C</b> Ammeter	The AMM-C ammeter displays the output current to the load. It can also be used as a status indicator; a zero reading indicating that no output current is being drawn by the load, while a pegged meter indicates a short circuit condition in the plant.
<b>TDR-M</b> Time Delay Relay	The TDR-M delays power to the output from 10 to 60 seconds reducing noise spikes and other transients that can occur with the start-up of utility power after an outage.
<b>ACAT-3P</b> Amp Clamp	<p>The ACAT-3P Amp Clamp protects active and passive equipment from voltage surges and transients. The plug-in clamp consists of two rugged silicon controlled rectifiers (SCRs) connected in an inverse parallel configuration with a steady state current of 35 Amps and a one cycle (8 ms) pulse rating of 500 Amps</p> <p>The SCRs are triggered into conduction whenever the Amp Clamp's bidirectional trigger diodes sense the presence of voltage transients exceeding 104V-115V peak threshold. The fast response trigger circuit gates the appropriate SCR ON (in nanoseconds) to shunt the surge current to ground, effectively protecting sensitive equipment from transient overvoltage conditions.</p>
<b>SIL-C</b> Status Indicator LED	The Status Indicator LED (red) indicates the APX2 is supplying AC output to the load. The long-life LED pilot lamp is visible from outside the enclosure. The LED remains ON as long as power is present at the module output. With this simple form of status monitoring, you can check the status of the power supply output without having to open the enclosure.

Table 1-1, Optional Features

## 2.0 Installation

### 2.1 Pole-mount Installations

The APX2 can be mounted on wooden, steel, or concrete poles.

In the majority of cases, local codes specify a minimum height requirement when mounting the enclosure. Verify height restrictions before you proceed.



#### CAUTION!

Use a bucket truck or suitable climbing equipment, such as a safety harness and spikes, whenever you work with pole-mount installations.



#### NOTE:

Poles are typically the property of your local utility. Before you install an enclosure, have your local utility approve the location and your chosen mounting method.

#### 2.1.1 Wooden Pole Installation

Materials required:

- 5/8" diameter machine bolt (UNC thread), SAE (Grade 5 or better), length to suit pole
- Two 5/8" diameter zinc-plated flat washers
- 5/8" diameter hex nut (UNC thread)

Tools required:

- Auger or drill for boring 3/4" diameter hole through wooden pole
- Mallet or hammer
- Assorted sockets or wrenches

Procedure:

1. Unpack the unit, including the galvanized bracket.
2. Mark the position for the mounting bracket on the utility pole.
3. Drill a 3/4" hole completely through the pole. Secure the bracket with a 5/8" machine bolt, washer and nut.
4. From the back of the enclosure back out the 3/8"-16" bolt sufficiently to mount the unit to the bracket.
5. Position the unit on the mounting bracket. It may be necessary to slightly rock the unit and pull downward to properly seat it on the bracket. Tighten the bolt loosened in step 4.



Fig. 2-1, Mounting Bracket for Wooden Pole

## 2.0 Installation, continued

### 2.1 Pole-mount Installations, continued



Fig. 2-2, Mounting Bracket for Steel or Concrete Pole

#### 2.1.2 Steel or Concrete Pole Installation

Materials required:

Customer supplied pole straps to secure the mounting bracket to the pole. Straps must be stainless, galvanized, or the equivalent.

Tools required:

Assorted sockets or wrenches

Procedure:

1. Unpack the unit, including the galvanized brackets.
2. Position the mounting bracket on the pole and secure it using your pole straps.
3. From the back of the enclosure back out the 3/8"-16" bolt sufficiently to mount the unit to the bracket.
4. Lift the unit onto the upper mounting bracket and pull downward to properly seat. Tighten the bolt loosened in step 3.

## 2.0 Installation, continued

### 2.2 Connecting the APX2

#### 2.2.1 AC Output Connection

Tools required:

1/8" flat-bladed screwdriver.



**NOTE:**

The center conductor may be trimmed to provide a flush fit. The length of the center conductor must be 1.25" from the end to the center of the O-Ring.

Procedure:

1. Prepare the incoming coaxial cable used for the distribution of power including the external fittings (not supplied by Alpha).
2. Loosen the brass seizure screw output fitting to accommodate the center pin of the cable connector.
3. Screw the cable connector into the output port (large hex nut fitting) located on the baseplate of the APX2. The center pin must extend far enough into the fitting so that the seizure assembly can be secured.
4. Firmly tighten the brass seizure screw on the cable or center pin. Arcing and damage to the center conductor can occur if a connection is left loose. As part of routine maintenance, always check the seizure screw to ensure it is tight.



Fig. 2-3, Brass Seizure Screw Location

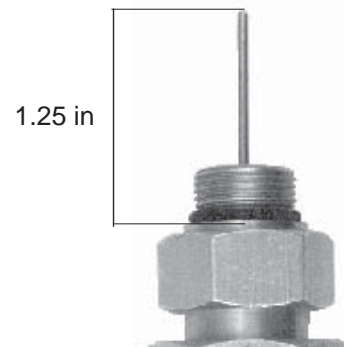
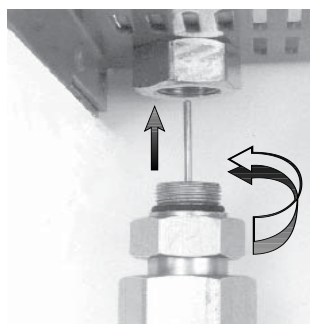

Fig. 2-4, Center Pin



Hex Nut Fitting

Fig. 2-5, Cable Connector/Output Port Assembly

## 2.0 Installation, continued

### 2.2 Connecting the APX2, continued

#### 2.2.2 Utility Power Connection

Utility power enters the enclosure through a 0.875" diameter opening at the base of the unit. The enclosure accepts a standard 1-inch conduit fitting.

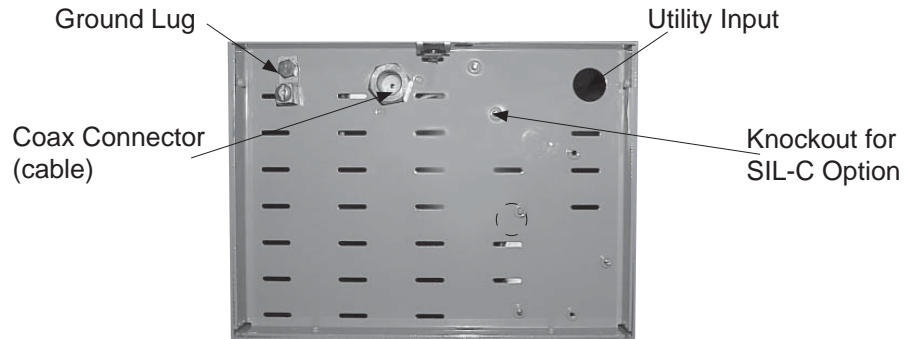

Fig. 2-6, APX2 Base

Tools required:

- 1/2" flat-bladed screwdriver
- 1/8" flat-bladed screwdriver

Procedure:

1. Connect the AC utility wire from the external service disconnect (see Section 2.2.3), to the input terminal block, located internally at the base of the APX2 enclosure.
2. Tie the ground lug of the APX2 enclosure to the Service Entrance (BBX), then bond it to an 8-foot copper ground rod.

Input Voltage	Terminal Block Connection
120/220/230VAC	<ul style="list-style-type: none"><li>• Line 1 connects to position 1</li><li>• Neutral connects to position 2</li><li>• Ground connects to position 3</li></ul>
240VAC	<ul style="list-style-type: none"><li>• Line 1 connects to position 1</li><li>• Line 2 connects to position 2</li><li>• Ground connects to position 3</li></ul>

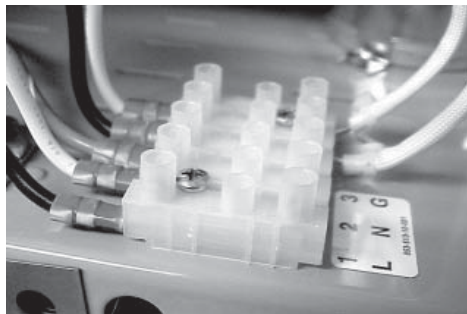

Fig. 2-7, Input Terminal Block

## 2.0 Installation, continued

### 2.2 Connecting the APX2, continued

#### 2.2.3 External Service Disconnect

**NOTE:**

The external service disconnect is customer supplied. Please consult the manufacturer and your local utility for specific installation instructions and guidelines.

An external service disconnect must be installed between the utility power connection and the APX2. All local utility and building codes apply.

- For pole mounted enclosures, attach the service disconnect directly to the utility pole using ¼" x 2-¼" steel wood screws.
- If a utility power meter is used, secure its mounting base in the same manner. Use a suitable conduit to interconnect the meter base, service disconnect, and the power supply enclosure.

**NOTE:**

Service electric ground must be unbroken to service disconnect.

**CAUTION!**

Use a "high-magnetic" trip breaker to accommodate the high inrush currents associated with the start-up of ferroresonant transformers (400A, no-trip, first-half-cycle). Do not replace this breaker with a conventional service entrance breaker.

High-magnetic Square D circuit breakers are available from Alpha, and are the only breakers recommended for use due to their increased reliability in this powering application.

Description	Alpha Part Number	Square D Part Number
220V/240V Installation (15A)	470-224-10	Q0215
120V Installation High-magnetic (20A)	470-017-10	Q0120HM
120V Installation High-magnetic (15A)	470-013-10	Q0115HM
BBX-External Service Disconnect	020-085-10	Q02-4L70RB (UL listed)

Table 2-1, Alpha Part Numbers for Square D Breakers

## 2.0 Installation, continued

### 2.2 Connecting the APX2, continued

#### 2.2.3 External Service Disconnect, continued

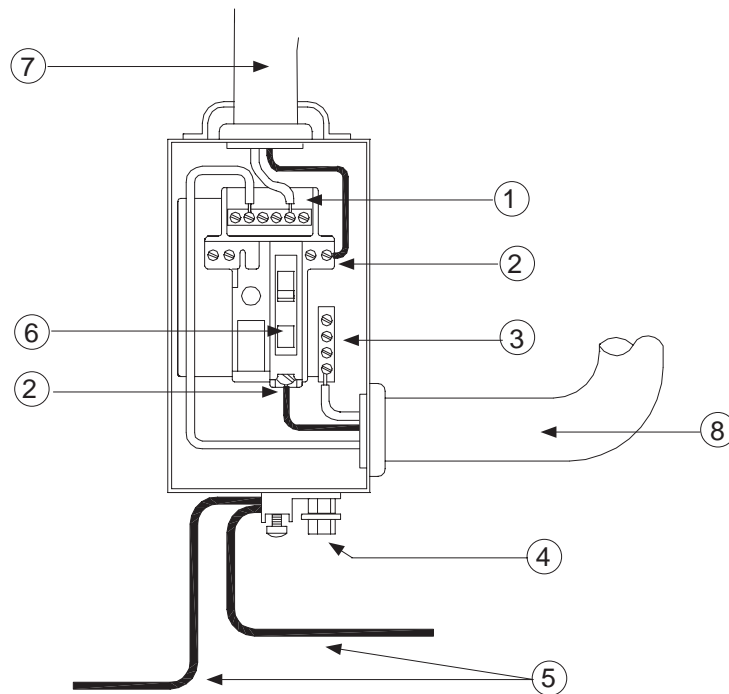

- |                |                                   |
|----------------|-----------------------------------|
| ① Neutral Bus  | ⑤ #8AWG (min) Copper Ground Wire  |
| ② Hot          | ⑥ Circuit Breaker (Sq D Q0115 HM) |
| ③ Ground Bus   | ⑦ To Utility                      |
| ④ Ground Clamp | ⑧ To Enclosure                    |

Fig. 2-8, Service Entrance / Meter Connections, 120VAC

## 2.0 Installation, continued

### 2.2 Connecting the APX2, continued

#### 2.2.3 External Service Disconnect, continued

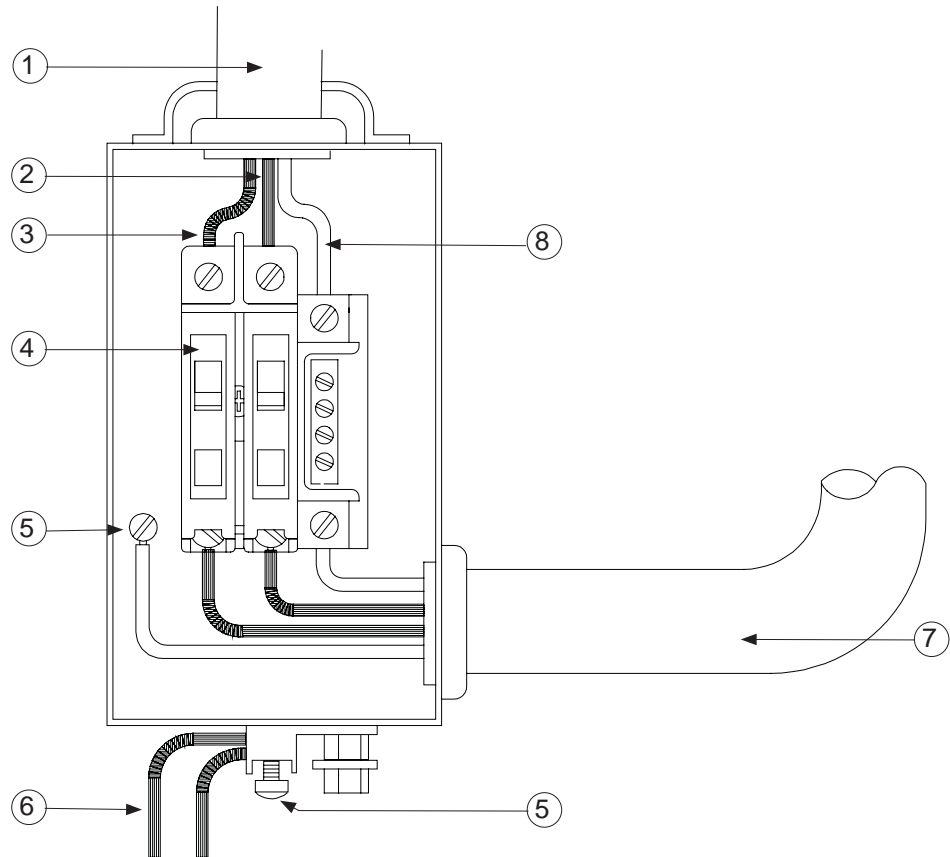

- |              |                              |
|--------------|------------------------------|
| ① To Utility | ⑤ Ground                     |
| ② L1 (Black) | ⑥ #8 AWG (min) Copper Ground |
| ③ L2 (Red)   | ⑦ To Enclosure               |
| ④ Breaker    | ⑧ Neutral                    |

Fig. 2-9 Service Entrance / Meter Connections, 240 VAC

## 2.0 Installation, continued

### 2.3 Options

Options for the APX2 non-standby power supply can be easily installed in the field in a minimum amount of time. See Section 1.3 for a complete list and description of the available options.



#### CAUTION!

Always disconnect the power supply from the unit before installing any optional features.



#### NOTE:

All options ordered with the APX2 are installed by Alpha. Use qualified service personnel to install additional options.

#### OP-APX2 (Option Plate)

Tools required:

1/4" wrench

Procedure:

1. Locate the pre-installed mounting screws, high on the inside wall of the APX2.
2. Align the option plate slots with their corresponding screws and tighten.

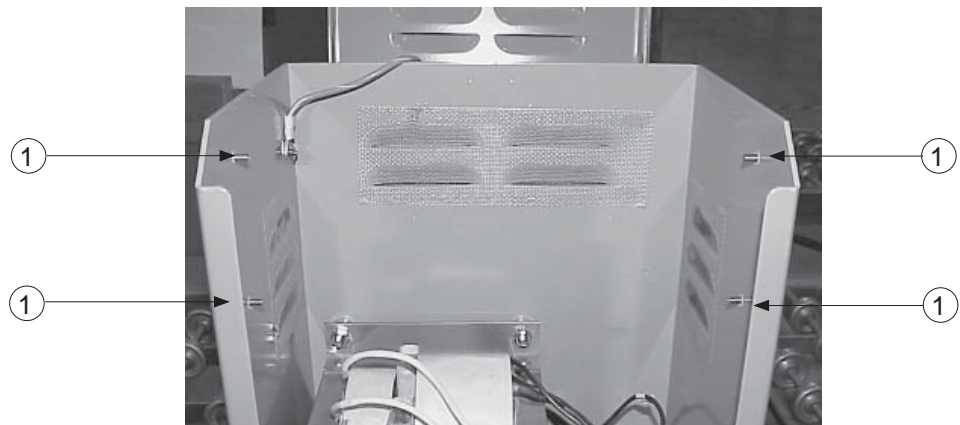

① Locations of mounting screws

Fig. 2-10, Screw Locations for Option Plate

## 2.0 Installation, continued

### 2.3 Options, continued



#### CAUTION!

Disconnect utility power before you install optional features.

#### CB-L (Input Line Circuit Breaker)

Tools required:

- Adjustable wrench
- 1/8" flat-bladed screwdriver

Procedure:

1. Remove the nut from the front of the circuit breaker. Place the circuit breaker into the position marked "Line" on the Option Plate, and replace the nut.
2. On the terminal block (located on the base of the APX2 enclosure), remove the Black wire jumper at positions 1 and 4.
3. Install the wire originating from the top of the circuit breaker into position 1 of the terminal block.
4. Install the wire originating from the bottom of the circuit breaker into position 4 of the terminal block.
5. Connect the APX2 to utility power and test the APX2 for proper operation.

#### CB-N (Input Neutral Circuit Breaker)

Tools required:

- Adjustable wrench
- 1/8" flat-bladed screwdriver

Procedure:

1. Remove the nut from the front of the circuit breaker. Place the circuit breaker into the position marked "Neutral" on the Option Plate, and replace the nut.
2. On the terminal block, remove the White jumper wire at terminals 2 and 5.
3. Install the wire originating from the top of the circuit breaker into position 2 of the terminal block.
4. Install the wire originating from the bottom of the circuit breaker into position 5 of the terminal block.
5. Connect the APX2 to utility power and test the APX2 for proper operation.



Fig. 2-11, Input Circuit Breaker Installed in Option Plate



Fig. 2-12, Input Terminal Block

## 2.0 Installation, continued

### 2.3 Options, continued

#### LA-P+ Series Surge Suppressor

Procedure:

To install the surge suppressor, plug the unit directly into the AC Duplex. The AC Duplex is located on the top left of the Option Plate. (See Fig. 1-4.)

#### AC-DX-120/240 (AC Duplex)

Tools required:

1/4" wrench

Procedure:

1. The AC Duplex is installed on the left side of the Option Plate. Use the two provided screws to fasten the receptacle into place.
2. The wiring package of the AC Duplex includes a five-position terminal block plug, that connects to the terminal block. Align pin #1 on the terminal block plug with position #1 on the terminal block.



#### NOTE:

Install the following options in the order listed. When you install options, always begin at the transformer and end at the output connector.

Install in this order: 1) Output Fuse; 2) Ammeter; 3) TDR-M; 4) Amp Clamp

In the event that one or more of these options is not present, continue to the next in the series. The SIL-C (Status Indicator LED) is connected independently of the other options.

#### Fuse (Output Fuse)

Procedure:

1. Plug the female connector of the output fuse into the male connector of the transformer, verifying appropriate voltage.
2. Plug the male connector of the Output Fuse into the female connector of the next option in the series, or into the VSF output if no other options are present. See Figs. 2-12 and 2-13.
3. Reconnect the APX2 to utility power and test for proper operation or continue to add options.

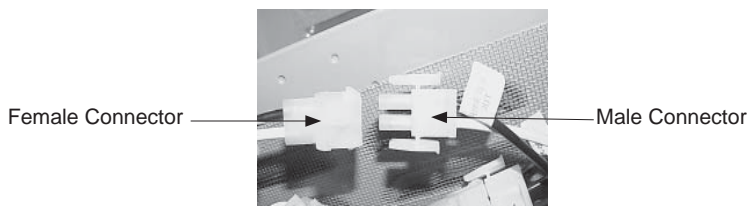

Fig. 2-13, Options Connectors



VSF Output

Fig. 2-14, VSF Output

## 2.0 Installation, continued

### 2.3 Options, continued

#### AMM-C (Ammeter)

Procedure:

1. The ammeter is placed in series with the output fuse and the TDR-M. Before you install the ammeter, disconnect the wire set from the fuse holder.
2. With the 0-Amp reading at the bottom, insert the ammeter into the corresponding slot on the option plate.
3. Slide the pressure clip completely forward until it makes contact with the option plate.
4. Plug the female connector into the output fuse, or, if no output fuse is present, into the transformer.
5. Plug the male connector into either the next option in the series, or if no other options are present, the VSF output.

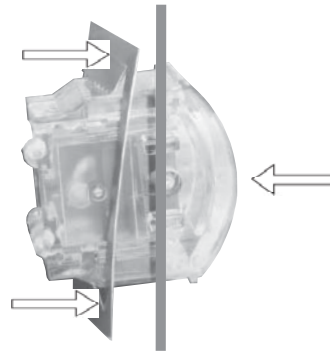

Fig. 2-15; Side View of Ammeter

#### TDR-M (Time Delay Relay)

Procedure:

1. Insert the insulating paper between the circuit board and the option plate.
2. Install the three plastic standoffs on the TDR-M circuit board, on the same side as the potentiometer. These standoffs will hold the TDR-M in place.
3. Install the TDR-M where the option plate is labeled "TDR-M Option." In a correct installation, the plastic standoffs hold the TDR-M in place and the potentiometer is pressed completely through the front of the option plate.
4. Plug the female connector of the TDR-M into the male connector of the previous option or, if no other options are present, into the transformer.
5. Plug the male connector of the TDR-M into the female connector of the next option or, if no other options are present, into the VSF output.

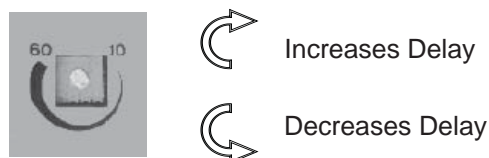

Fig. 2-16; TDR-M Potentiometer

## 2.0 Installation, continued

### 2.3 Options, continued

#### ACAT-3P (Amp Clamp)

Procedure:

1. Insert the insulating paper between the circuit board and the option plate.
2. Install the three plastic standoffs on the ACAT-3P circuit board on the side with no components. These standoffs hold the ACAT-3P in place.
3. Install the Amp Clamp where the option plate is labeled "ACAT Option". The plastic standoffs hold the ACAT-3P in place.
4. Plug the female connector of the ACAT-3P into the male connector of the previous option in the series or, if no other options are present, into the transformer.
5. Plug the male connector of the ACAT-3P into the female connector of the next option in the series or if no other options are present, into the VSF output.
6. Connect the APX2 to utility power and test for proper operation.

#### SIL-C (Status Indicator LED)

Tools required:

- 1/2" flat-bladed screwdriver
- Adjustable wrench

Procedure:

1. Using 1/2" flat-bladed screwdriver, remove the knockout plug from the base of the APX2 enclosure.
2. Route the connector of the SIL-C option up through the knockout hole and into the base of the enclosure.
3. Route the large star washer and nut over the connector and wires of the SIL-C. Screw the nut onto the threaded portion of the lamp's base and tighten.
4. Plug the male connector of the SIL-C into the female connector of the VSF.
5. Connect the APX2 to the utility power and test the APX2 for proper operation. See Section 3.1 for the testing procedure.

SIL-C Installed  
in Baseplate



Fig. 2-17, SIL-C Installation

## 3.0 Start-up and Test

Test the APX2 before you place it into service. You can begin testing once all utility and cable connections are complete.

Procedure:

1. Before you apply power, verify that the AC LINE circuit breaker (if installed) is in the OUT (off) position. In the OUT position the white portion of the stem is visible. If it is not in the OUT position, depress the breaker button until it resets.
2. Switch the external service entrance breaker (located outside of the enclosure) to ON.
3. Press the breaker button to reset the APX2 internal AC circuit breaker (if installed). The white portion on the stem is not visible.
4. Using a true reading RMS digital multimeter, measure the output voltage at the output connector of the APX2. The voltage should read between 60VAC and 65VAC for 60VAC output models, and 83 and 91VAC for 90VAC output models.
5. If you have installed the ammeter option, verify that the current draw is in the correct range. For example, below 8A for an 8A unit or below 14A for a 14A unit.
6. Close the cover on the APX2. Secure the hold-down screw and lock the enclosure.



### NOTE:

In step 4, if you use a non-RMS type voltmeter, your reading may be off by as much as 10% due to the “quasi” square wave output of the ferroresonant transformer.

## 4.0 Troubleshooting and Repair

### 4.1 Troubleshooting

Symptom	Probable Cause	Remedy
No output to cable (No AC line power)	Utility power outage	Use voltmeter to verify 120VAC or 230VAC at receptacle
	Poor or no connection terminal block	Verify that connection has been made and is securely tightened

Table 4-1, Troubleshooting



### NOTE:

Alpha Technologies is not responsible for damage caused by the improper packing of returned units.

## 4.0 Troubleshooting and Repair, continued

### 4.2 Repair Instructions

To return a unit to Alpha Technologies for repair:

- Obtain a Return Material Authorization (RMA) from Alpha Technologies, ([www.alpha.com](http://www.alpha.com), select Support link). Clearly mark the RMA on the original shipping container. If the original container is not available, pack the unit in at least 3 inches of shock absorbent material.
- As an aid to the service department, please include the power supply maintenance log when returning a unit for service.
- Do not use popcorn type packing material.
- Prepay and insure shipment. COD and freight collect shipments are not accepted.

### 4.3 Parts and Ordering Information

The following parts can be replaced in the field and are available from Alpha Technologies. When ordering parts, please specify the model number on the nameplate, and the part number listed below.

Type	Description	Part Number	Used in Model
Capacitors	Oil Filled 12 $\mu$ F; 660VAC	210-007-12	APX2 608E
	Oil Filled 60 $\mu$ F; 370VAC	210-017-10	APX2 614
	Oil Filled 18 $\mu$ F; 240VAC	210-010-10	APX2 614E, 614P
	Oil Filled 20 $\mu$ F; 240VAC	210-011-10	APX2 915 (120V or 240V)

Table 4-2, Replacement Parts

## 4.0 Troubleshooting and Repair, continued

### 4.4 Schematic/Block Diagram

This diagram illustrates the main components of the APX2 Non-Standby power supply, including where options are electrically installed in the circuit. For detailed instructions on installing options please refer to Section 2.4, Options.

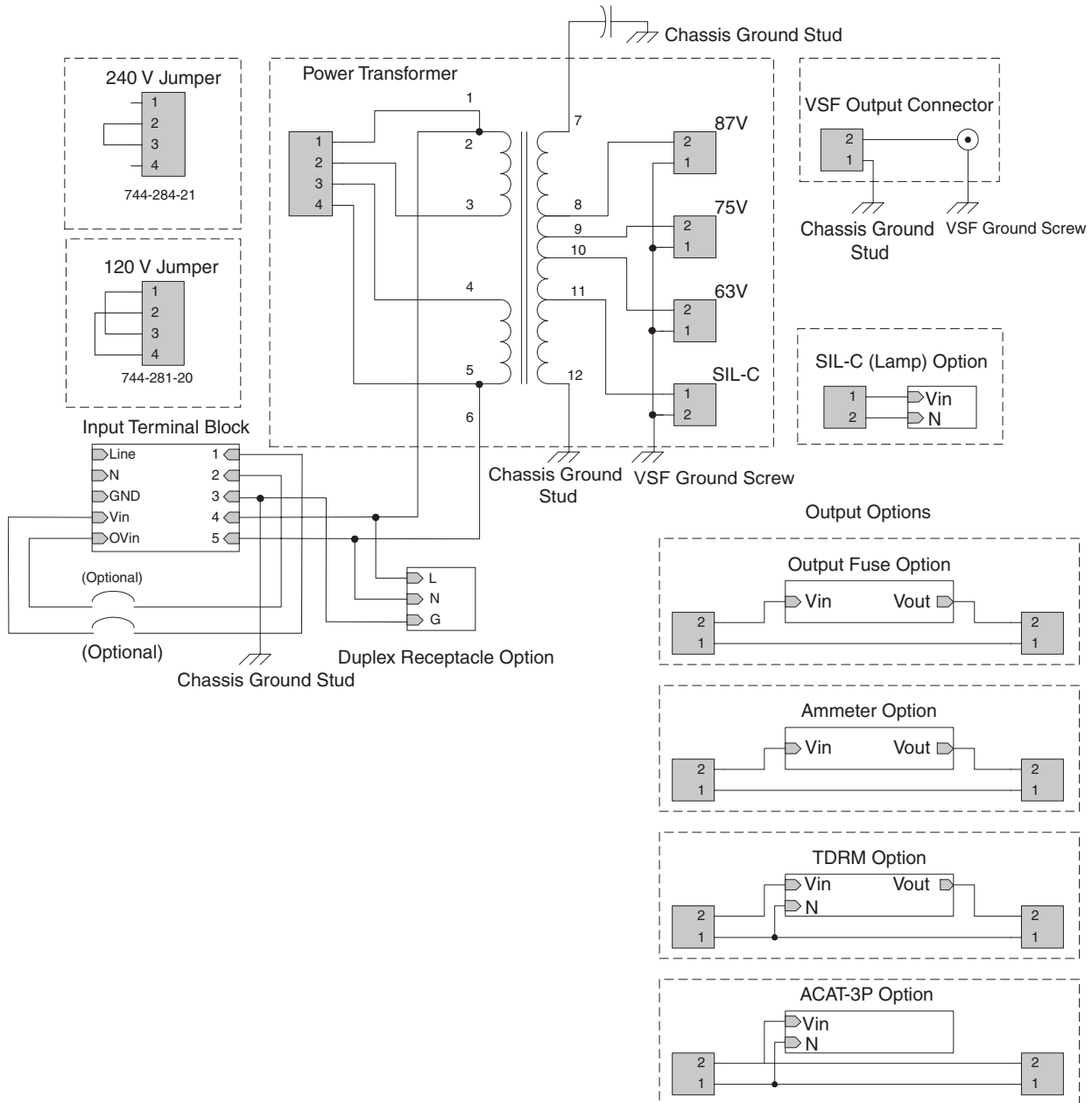

Fig. 4-1, APX2 Schematic

## 5.0 Specifications

MODEL	APX2 608E	APX2 614	APX2 614P	APX2 614E	APX2 915 (120V)	APX2 915 (240V)
Input Voltage (VAC)	230 ± 20%	120 ± 20%	220 ± 20%	230 ± 20%	120 ± 20%	240 ± 20%
Input Frequency (Hz)	50 ± 3%	60 ± 3%	60 ± 3%	50 ± 3%	60 ± 3%	60 ± 3%
Input Current (A)	5.3 Max	7 Max	5.3 Max	5.3 Max	11.2 Max	5.6 Max
Output Voltage (VAC)	60	60	60	60 (48V option)	90/75/60	90/75/60
Output Current (A)	8 Max	14 Max	14 Max	14 Max	15 Max	15 Max
Output Power (VA)	480	840	840	840	1350	1350
Output Current Limit	150% of Output Rating	150% of Output Rating	150% of Output Rating	150% of Output Rating	150% of Output Rating	150% of Output Rating
Regulation	± 5%	± 5%	± 5%	± 5%	± 5%	± 5%
Input	15 Amp	15 Amp	15 Amp	15 Amp	20 Amp	15 Amp
Output Protection (Fuse)	15 Amp	15 Amp	15 Amp	15 Amp	20 Amp	20 Amp
Efficiency	90%	90%	90%	90%	90%	90%
Finish	Gray powder Coat	Gray powder coat	Gray Powder Coat	Gray Powder Coat	Gray powder Coat	Gray Powder Coat
Operating Temperature Range	-40°F to +130°F(-40°C to +55°C)	-40°F to +130°F(-40°C to +55°C)	-40°F to +130°F(-40°C to +55°C)	40°F to +130°F(-40°C to +55°C)	-40°F to +130°F(-40°C to +55°C)	-40°F to +130°F(-40°C to +55°C)
Dimensions (HxWxD)	15" x 10.5" x 7.5"	15" x 10.5" x 7.5"	15" x 10.5" x 7.5"	15" x 10.5" x 7.5"	15" x 10.5" x 7.5"	15" x 10.5" x 7.5"
Weight (lbs/kg)	32/14.5	32/14.5	32/14.5	32/14.5	48/21.7	48/21.7

Table 5-1, APX2 Specifications

Specifications subject to change without notice.



# Power

Alpha Technologies



Alpha Technologies  
3767 Alpha Way  
Bellingham, WA 98226  
**USA**  
Tel: +1 360 647-2360  
Fax: +1 360 671-4936  
Web: www.alpha.com

Alpha Technologies Ltd.  
4084 McConnell Court  
Burnaby, BC, V5A 3N7  
**CANADA**  
Tel: +1 604 430-1476  
Fax: +1 604 430-8908

Alpha Technologies  
Europe Ltd.  
Twyford House  
Thorley  
Bishop's Stortford  
Hertfordshire  
CM22 7PA  
**UNITED KINGDOM**  
Tel: +44 (0)1279-501110  
Fax: +44 (0)1279-659870

Alpha Technologies GmbH  
Hansastraße 8  
D-91126 Schwabach  
**GERMANY**  
Tel: +49-9122-79889-0  
Fax: +49-9122-79889-21

Alphatec, Ltd  
P.O. Box 56468  
Limassol, Cyprus  
**CYPRUS**  
Tel: +357-25-375675  
Fax: +357-25-359595

AlphaTEK ooo  
Khokhlovskiy Pereulok 16  
Stroenie 1, office 403  
109028 Moscow  
**RUSSIA**  
Tel: +7 495 916 1854  
Fax: +7 495 916 1349

Alphatec Baltics  
S. Konarskio G. 49  
Vilnius 2009  
**LITHUANIA**  
Tel: +350 5 210 5291  
Fax: +350 5 210 5292

Alpha Technologies  
5 Avenue Victor Hugo  
F-92140 Calmart France  
**FRANCE**  
Tel: +33-3-41-90-07-07  
Fax: +33-1-41-90-93-12