

Alpha APX2-G

Indoor Series

Non-standby Power Supplies

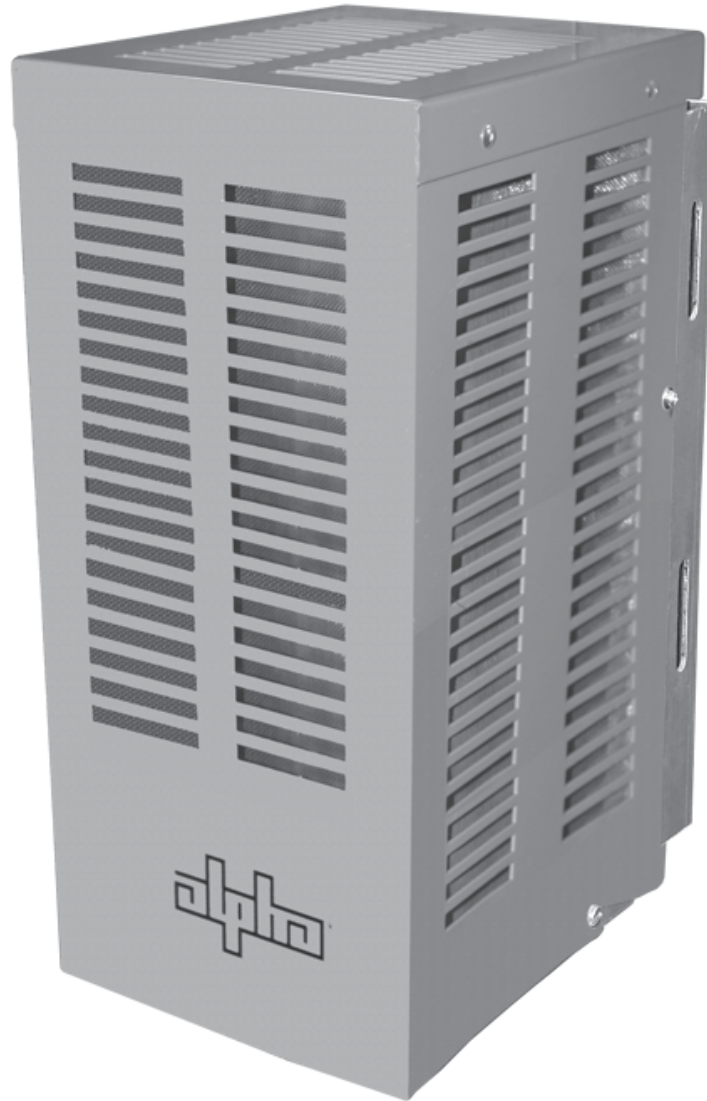

Alpha APX2-G Series

Installation Manual

Effective: September, 2005

Alpha Technologies 
Power

Alpha APX2-G Mesh Cover Series Installation Manual

016-550-B4-001, Rev. A

Copyright© 2005

Alpha Technologies, Inc.

member of The  Group™



NOTE

Photographs contained in this manual are for illustrative purposes only. These photographs may not exactly match your installation.



NOTE

Review the drawings and illustrations contained in this manual before proceeding. If there are questions regarding the safe operation of this powering system, please contact Alpha Technologies or your nearest Alpha representative.



NOTE

Alpha denies responsibility for any damage or injury involving its enclosures, power supplies, generators, batteries, or other hardware when used for an unintended purpose, installed or operated in an unapproved manner, or improperly maintained.

For general **Alpha Technologies** product information and customer service:

- **www.alpha.com**
- **+49-9122-79889-0 (Western and Eastern Europe)**
- **+86-10-8462-6760 (China)**

For complete **technical support**:

1-360-647-2360

(7:00 AM to 5:00 PM Pacific Time, or 24/7 emergency support)

Table of Contents

Important Safety Instructions.....	5
1.0 Overview and Specifications	8
1.1 The Alpha APX2-G Indoor Series	8
1.2 Alpha APX2-G Indoor Series Specifications	10
1.3 Theory of Operation.....	10
1.4 Operation	11
2.0 Installing an Alpha APX2-G Mesh Cover Indoor Unit	12
2.1 Wall-mount Installations.....	12
2.2 Connecting an Alpha APX2-G Unit	14
2.2.1 AC Output Connection	14
2.2.2 Utility Power Connection.....	15
2.2.3 External Service Disconnect.....	15
3.0 Initial Startup.....	16
4.0 Troubleshooting and Repair	17
4.1 Troubleshooting	17
4.2 Important Repair Instructions.....	17
4.3 Parts and Ordering Information	17
4.3.1 Ordering	17
4.3.2 Replacement Parts	18
4.4 Schematic of the Alpha APX2-G Non-Standby power supply.....	18
Mounting Template	19

List of Figures

Fig. 1-1, Alpha APX2-G Indoor Series Non-standby Power Supply (front view).....	8
Fig. 1-2, Alpha APX2-G without Cover (left side view)	9
Fig. 1-3, Alpha APX2-G without Cover (right side view)	9
Fig. 1-4, Ferroresonant 'Tank' Circuit and Resulting Output Waveform	11
Fig. 1-5, Alpha APX2-G Operational Controls	11
Fig. 2-1, Wall-mount Holes on APX2-G	12
Fig. 2-2, Possible Wall-mounting Orientations	13
Fig. 4-1, Alpha APX2-G Schematic.....	18

Important Safety Instructions!

Review the drawings and illustrations contained in this manual before proceeding. If there are any questions regarding the safe installation or operation of the system, contact Alpha Technologies or the nearest Alpha representative. Save this document for future reference.

To reduce the risk of injury or death caused by electrical shock, explosion of fuel or moving parts; and to ensure the continued safe operation of this product, the following symbols have been placed throughout this manual. Where these symbols appear, use extra care and attention.

ATTENTION

Alpha Technologies' products are subject to change through continual improvement processes. Therefore, specifications and/or design layouts may vary slightly from descriptions included in this manual. Updates to the manual will be issued when changes affect form, fit or function.

ATTENTION

The use of ATTENTION is only for specific regulatory/code requirements that may affect the placement of equipment and installation procedures.

Symbols you may see in this Manual



NOTE:

A NOTE gives readers additional information to help them complete a specific task or procedure.



CAUTION!

A CAUTION presents safety information to PREVENT DAMAGE TO Alpha or CUSTOMER'S EQUIPMENT. A CAUTION tells you how to correctly perform a procedure or action and what could happen if you fail to follow the instructions.



WARNING:

A WARNING presents safety information to PREVENT INJURY OR DEATH to the technician/user. A WARNING tells you how to take specific safety precautions and then explains what may happen if those precautions are not followed.

Unpacking and Inspection

Carefully remove the unit from its shipping container and inspect for damage. If items are damaged or missing, immediately contact Alpha Technologies and the shipping company. Most shipping companies have a short claim period.

Save the original shipping container. It provides support for the unit during shipping.

If you need to return a unit for service, repackage it in its original shipping container. If you do not have the original shipping container, repack the unit with at least 8 centimeters of shock-absorbing material to prevent shipping damage.



NOTE

Do not use popcorn-type packing material. Alpha Technologies is not responsible for damage caused by improper packing on returned units.

General Safety Precautions



CAUTION!

This product and its associated hardware may contain equipment, or parts which have accessible hazardous voltage or currents.

To avoid injury:

- This enclosure and its associated hardware must be serviced only by authorized personnel.
- Enclosure must remain locked at all times, except when authorized service personnel are present.
- Remove all conductive jewelry or personal equipment prior to servicing equipment, parts, connectors, wiring, or batteries.
- Read and follow all installation, equipment grounding, usage, and service instructions included in this manual.
- Use proper lifting techniques whenever handling enclosure, equipment, or parts.
- Never use uninsulated tools or other conductive materials when installing, maintaining, servicing or replacing this equipment.



CAUTION!

Enclosure, equipment or parts may be damaged or cause damage if used or installed improperly.

To avoid damage:

- Prior to installation, verify that the AC input voltage to the equipment matches with respect to voltage and frequency.
- Prior to installation, verify that the output voltage from the equipment matches the voltage requirements of the connected equipment (load).
- Prior to installation, verify that the enclosure's utility service panel is equipped with a properly rated circuit breaker for use with the equipment inside. Refer to manufacturer's recommendations.
- Review and upgrade utility service panel circuit breaker requirements whenever the equipment within the enclosure is changed.
- Prior to installation, contact local utilities, local building maintenance departments, and cable/piping locator services to ensure that installation does not interfere with existing utility or building cables/piping.
- Do not exceed the output rating of equipment. Verify load requirements prior and during connection process.

Electrical Safety

- Lethal voltages are present within the power supply and electrical boxes. Never assume that an electrical connection or conductor is not energized. Check the circuit with a volt meter with respect to the grounded portion of the enclosure (both AC and DC) prior to any installation or removal procedure.
- Do not work alone under hazardous conditions.
- A licensed electrician is required to install permanently wired equipment.
- Input voltages can range up to 240 VAC. Ensure that utility power is disabled before beginning installation or removal.
- Ensure no liquids or wet clothes contact internal components.
- This equipment works continuously.

Mechanical Safety

- Power supplies can reach extreme temperatures under load.
- Use caution around sheet metal components and sharp edges.

1.0 Overview and Specifications

1.1 The Alpha APX2-G Indoor Series

The Alpha APX2-G Indoor non-standby power supply series provides conditioned power to signal amplifiers in cable television and broadband distribution systems. The transformer is mounted directly to the chassis, and supplies the load with current-limited, regulated AC power that is free from disturbances caused by spikes, surges and other forms of power line transients.

The Alpha APX2-G Indoor series is a non-standby power supply designed for indoor use. The inexpensive, reliable, and versatile Alpha APX2-G indoor series can be wall-mounted in either a vertical or horizontal orientation or mounted on a wooden, steel, or concrete pole.

 **NOTE:**

Outdoor versions of the Alpha APX2-G non-standby power supply are available. Contact your nearest Alpha representative for information.

The Alpha APX2-G indoor units contain a ferroresonant transformer, a resonant circuit capacitor, a terminal block, and are equipped with an input fuse, input line switch, visual output “ON” indicator, output coaxial terminal, ground connection, and a current shunt for output current measurement. They deliver safe operations in all load conditions.

The Alpha APX2-G indoor series, along with the entire line of Alpha power products, is designed to be one of the most rugged, reliable, and cost-effective power supplies available. With over a million powering installations in more than 50 countries, Alpha is one of the world’s leading suppliers of reliable communication powering and offers complete technical support and prompt, reliable service to ensure that your power supply provides you with years of trouble-free operation.

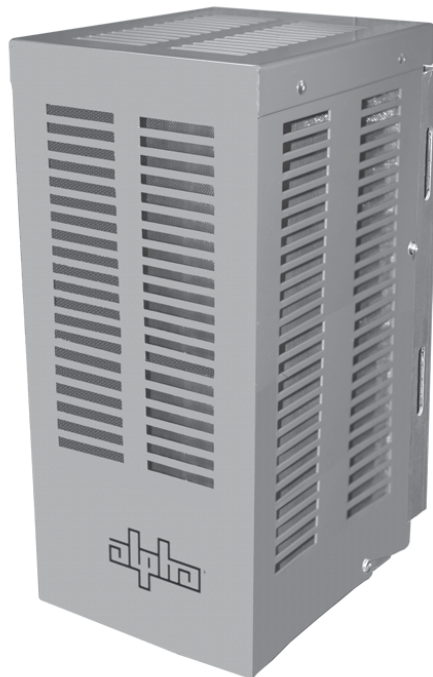

Fig. 1-1, Alpha APX2-G Indoor Series Non-standby Power Supply (front view)

1.0 Overview and Specifications, *cont*

1.1 The Alpha APX2-G Indoor Series

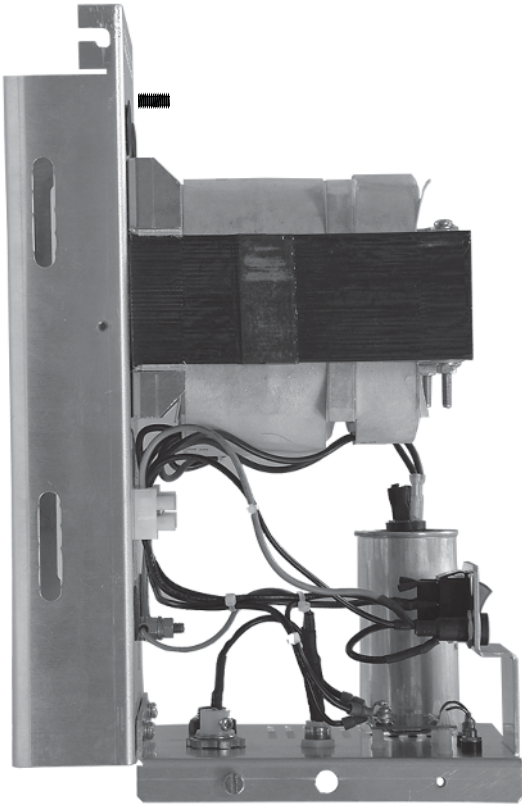
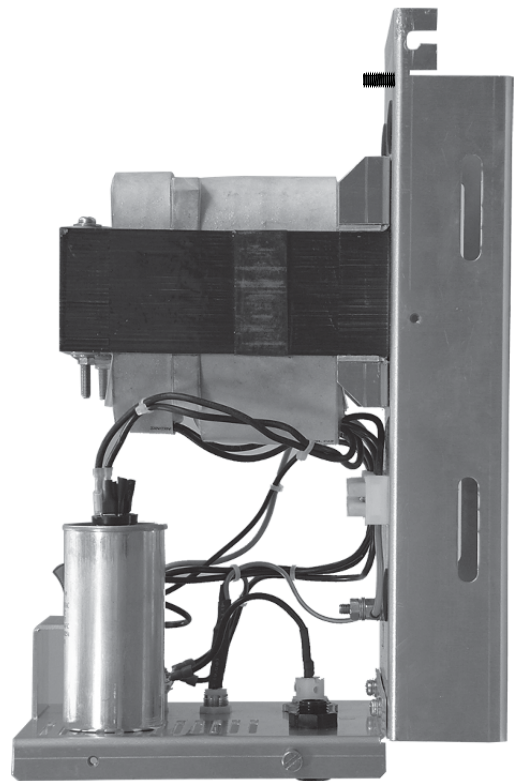

Fig. 1-2, Alpha APX2-G without cover (left side view)

Fig. 1-3, Alpha APX2-G without cover (right side view)



1.0 Overview and Specifications, *cont.*

1.2 Alpha APX2-G Indoor Series Specifications

Model	Input Voltage	Frequency	Output Voltage	Output Current (maximum)
608 G	220/230VAC, $\pm 20\%$	50Hz $\pm 3\%$	48/63V, $\pm 5\%$	8A
615 G	220/230VAC, $\pm 20\%$	50Hz $\pm 3\%$	48/63V, $\pm 5\%$	15A
905 G	220/230VAC, $\pm 20\%$	50Hz $\pm 3\%$	63/87V, $\pm 5\%$	5A
910G	220/230VAC, $\pm 20\%$	50Hz $\pm 3\%$	63/87V, $\pm 5\%$	10A
614 G	100/200VAC, $\pm 20\%$	60Hz $\pm 3\%$	63V, $\pm 3\%$	14A
614 G	200/240VAC, $\pm 20\%$	60Hz $\pm 3\%$	63V, $\pm 3\%$	14A
Operating temperature range for all models			-40°C to +50°C	
Humidity rating			95% (non-condensing)	
Unit weights				
Models 614/615/910		15.88kg		
Models 608/905		12.7kg		
Dimensions, overall		370mm H x 170mm W x 240mm D		

1.3 Theory of Operation

The APX2-G Indoor Series non-standby power supply uses ferroresonant transformer technology to provide line conditioning and voltage regulation. The primary and secondary windings of the transformer are physically isolated from each other by a large steel core which significantly reduces the capacitive coupling of spikes and noise to the secondary winding. This provides a regulated, current-limited output with excellent isolation and noise attenuation: 140dB common mode; 80dB transverse mode.

An oil-filled resonant AC capacitor is connected to the resonant (secondary) winding of the transformer forming a *tank circuit*. This provides the resonant circuit function which contributes to the voltage regulation of the supply. The advantage of this type of transformer/capacitor design is the ability of the ferroresonant transformer to regulate its output voltage over a wide range of input voltages and output loading. Typical output voltages may vary $\pm 5\%$ with 90% efficiency, with input voltage variations of $\pm 20\%$ of nominal line voltage, and output loading of 20% to 100%. This tight regulation is advantageous in cable television applications as the active devices are protected from dangerous voltage fluctuations.

Another unique feature of the ferroresonant transformer is its ability to provide current limiting in the event of a short-circuit. This effect is called *foldback*. The transformer's output current can typically reach 150% of the nameplate output current rating for a short period of time without damage to the transformer. When the transformer reaches the saturation point, the output current will decrease (foldback on itself) to a minimum value, and thereby provide current limiting. Designs based on a ferroresonant transformer are extremely rugged and reliable, and offer many years of trouble-free operation.

Alpha's non-standby power supplies are extremely efficient, and have a typical efficiency rating of $>90\%$ at full load.

1.0 Overview and Specifications, *cont.*

✓ NOTE:

Use a true RMS voltmeter to correctly measure the output voltages.

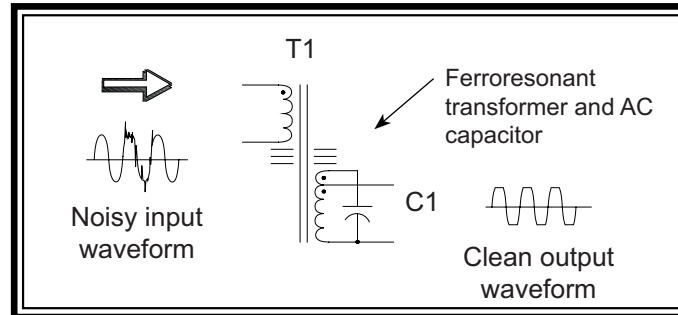

Fig. 1-4, Ferroresonant 'Tank' Circuit and Resulting Output Waveform

The output waveform from the ferroresonant transformer is not a true sine or square wave, but is instead a quasi-square wave.

1.4 Operation

✓ NOTE:

All controls and indicators for the Alpha APX2-G, except the power switch, are accessible on the faceplate of the unit.

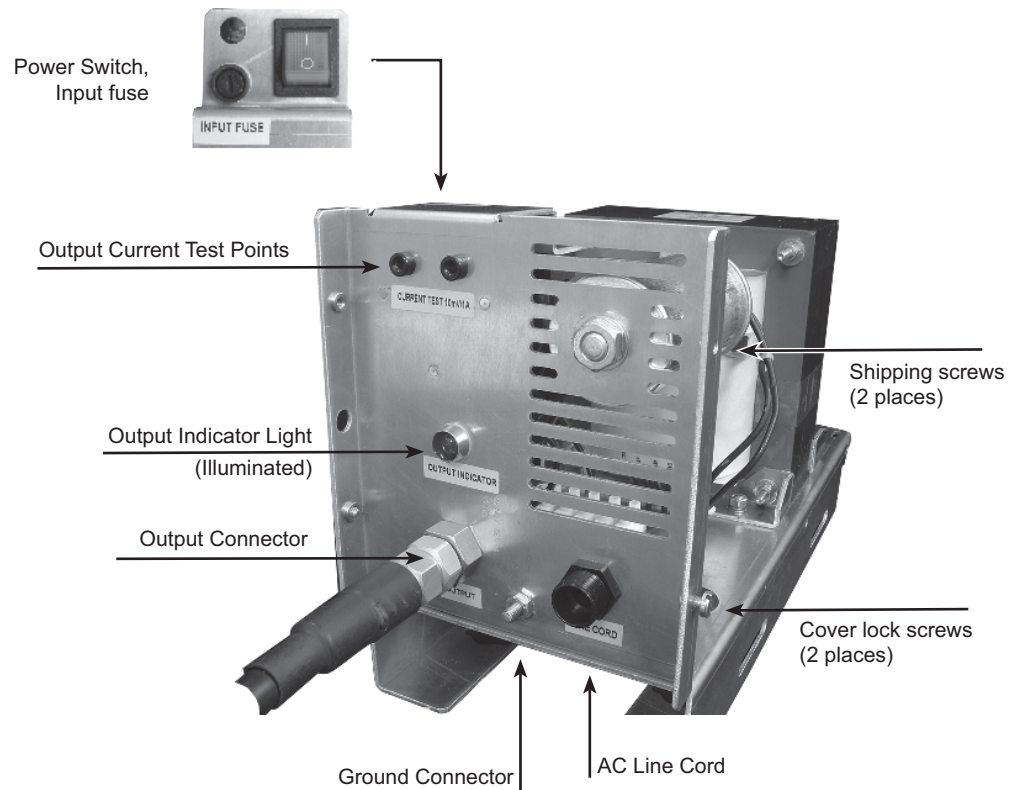

Fig. 1-5, Alpha APX2-G Operational Controls

2.0 Installing an Alpha APX2-G Indoor Unit



NOTE:

Install equipment strictly according to the installation instructions provided.

2.1 Wall Mounting Procedure

For wall mounting, securely fasten the unit to the wall with four 8mm screws of appropriate length to support the unit.

Required Materials

Four 8mm screws appropriate for the mounting surface

Required Tools

Assorted screwdrivers, sockets or wrenches

1. Unpack the unit.
2. Remove the two securing screws from the bottom exterior sides of the cover and remove the cover from the chassis.
3. Position the APX2-G chassis in the correct location. The unit is mounted using the keyhole slots on the mounting flanges and can be mounted either vertically or horizontally. See Fig. 2-3 and 2-4.
4. Use the supplied template (last page of this manual) to mark the location of the mounting holes.
5. With an appropriate drill bit, drill the four holes for mounting.
6. Screw the four screws into the mounting surface. Leave approximately 2-3mm between the screw head and mounting surface.
7. Remove the plastic covers in the front of the mounting holes.
8. Align the APX2-G unit mounting holes over the screws and slide the chassis downward into the slots. Securely tighten the top screws by inserting the screwdriver through the access holes in the back of the chassis. Replace the four plastic plugs, making sure they properly fit.
9. Continue to Section 2.2 Connecting an Alpha APX2-G Unit.

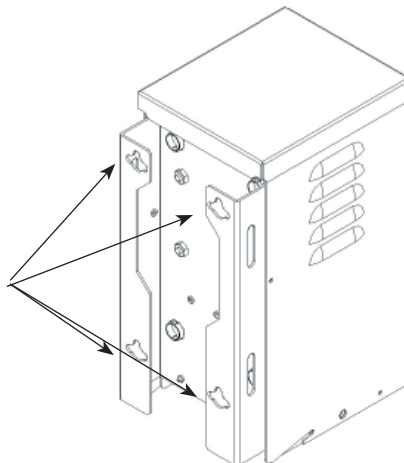
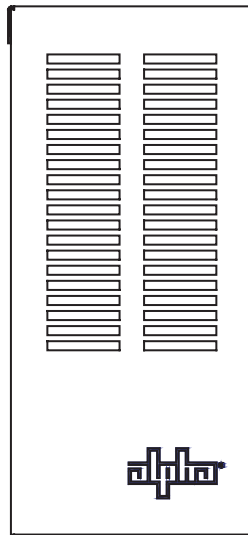
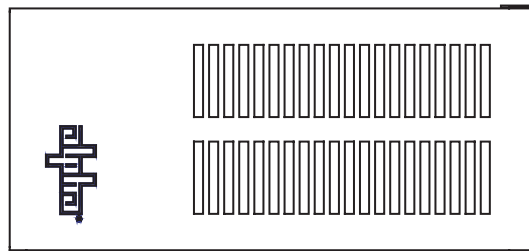

Fig. 2-1 Wall mounting holes of the APX2-G

2.0 Installing an Alpha APX2-G Unit, *cont.*



Vertical Wall Mount



Horizontal Right Facing Wall Mount

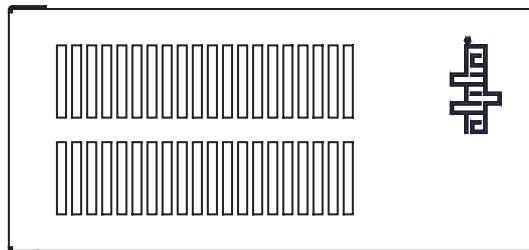

Horizontal Left Facing Wall Mount

Fig. 2-2 Possible wall mounting orientations

2.0 Installing an Alpha APX2-G Unit, *cont.*

2.2 Connecting the Alpha APX2-G

2.2.1 AC Output Connection

Tools required: appropriate open-end wrenches and screwdrivers

1. Prepare the incoming coaxial cable used for the distribution of power (including external fittings not supplied by Alpha).
2. Loosen the seizure screw output fitting to accommodate the center pin ("stinger") of the cable connector.

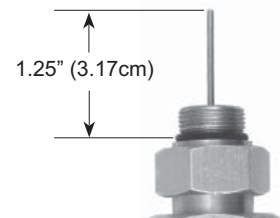
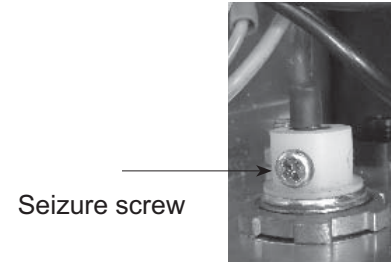

NOTE:

The center conductor may be trimmed to allow for a flush fit. The length of the center conductor must be 1.25" (3.17cm) from the end to the center of the O-Ring.

3. Screw the cable connector into the output port (large hex nut fitting) located on the baseplate of the Alpha APX2-G. Make sure that the center pin extends far enough into the fitting so that the seizure assembly can be secured.



4. Tighten the brass seizure screw on the cable "stinger" or center conductor to 25 in-lbs (2.82N-m).

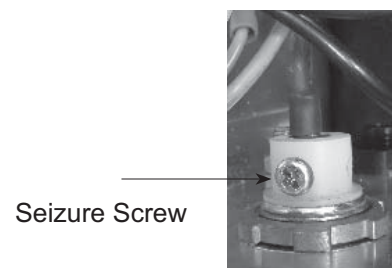

2.0 Installing an Alpha APX2-G Unit, *cont.*

2.2.1 AC Output Connection, *cont.*

WARNING!

It is important to adequately tighten the cable “stinger” seizure screw as arcing may occur due to a loose connection. During routine maintenance, always check the seizure screw assembly to ensure that it is tight. Alpha is not responsible for damage to equipment or personnel because of incorrect taps or loose connections.

5. Choose the right tie-in for power from the terminal block of the transformer. For the APX2-608G and APX2-615G, the output default is 63V (shown). For the APX2-905G and -910G, the default output voltage from the primary tap of the transformer (not shown) is 87V .

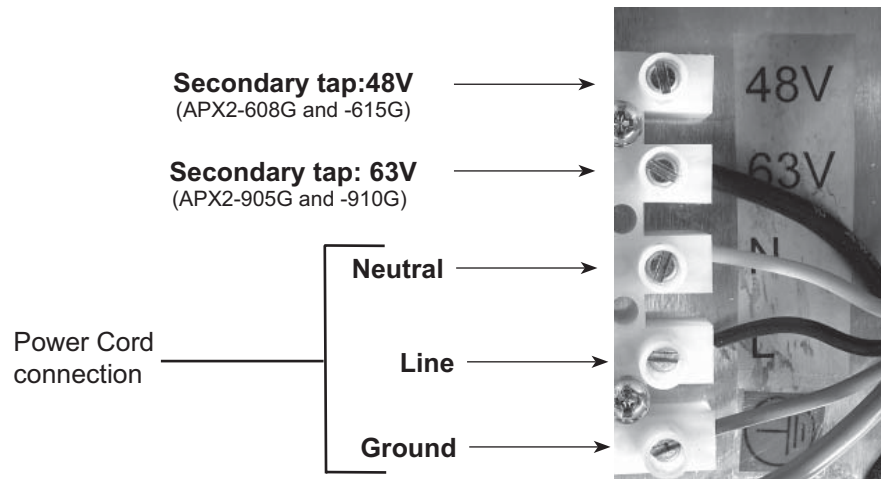

NOTE:

To change voltage outputs from 63V to 48V (see picture) or 87V to 63V, select the appropriate tie-in, then tighten the screws on the terminal block.

2.2.2 Utility Power Connection

The APX2-G is supplied without a line cord to allow the installer to select the most suitable cord and plug for the installation (14 AWG is recommended). The power cord is installed as indicated above. The cable fitting is equipped with a strain relief clamp to securely attach the line cord.

2.2.3 External Service Disconnect

If installing an external service disconnect, locate it between the utility power connection and the Alpha APX2-G unit. (The customer supplies the external service disconnect. Please consult manufacturer or local power utility company for specific installation instructions and guidelines.)

NOTE:

Install a “high magnetic” trip breaker rated for 220/240V, 15A normally used in HVAC (Heating, Ventilation, Air Conditioning) applications to accommodate the high-inrush currents associated with the start-up of ferroresonant transformers (400 Amp, no-trip, first-half cycle).

3.0 Initial Startup

Test the Alpha APX2-G before placing it into service. Start testing after utility and cable connections have been made.

Procedure:

1. Before applying power, verify that the AC LINE input switch is in the OFF position.
2. If present, switch the external service entrance breaker (located outside of the enclosure) to ON. Use a true RMS voltmeter to verify correct input voltage
3. Activate Alpha APX2-G by pressing the input switch to ON. The switch will illuminate to indicate that power is present.
4. Use a true reading RMS digital multimeter to measure the output voltage at the output connector of the Alpha APX2-G. The voltage will read between 60 and 65VAC for 63VAC output.

NOTE:

If you use a non-RMS type voltmeter, the reading can be off by as much as 10% due to the “quasi” square-wave output of the ferroresonant transformer.

5. The APX2-G is equipped with a 10mV/1A shunt as shown below. The current draw must not exceed 8A (maximum) for the APX2-608G model, and 15A (maximum) for the APX2-615G model.

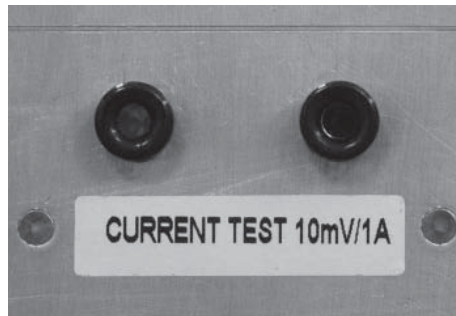

6. Remove power from unit.
7. Install and close the cover on the Alpha APX2-G. Secure the hold-down screw and lock the enclosure.

NOTE:

If the unit is noisy after Step 6, remove the cover, then make sure it aligns with the side rails as you again replace the cover.

4.0 Troubleshooting and Repair

4.1 Troubleshooting

Symptom:	Probable Cause:	Remedy:
No output to cable	Utility power outage	Check input switch light indicator. (Verify switch is on.) Check input fuse. Replace with same type of fuse Use voltmeter to verify 220/230VAC at receptacle. Check output indicator light.

Alpha Technologies recommends that the power supply maintenance log accompany units brought in for bench service to aid the technician in troubleshooting the problem.

4.2 Important Repair Instructions

Before returning a unit to Alpha Technologies for repair, contact the nearest Alpha repair facility or sales office to obtain a Return Material Authorization (RMA) number. The RMA must be clearly marked on the unit's original shipping container. If the original container is no longer available, pack the unit in at least 3 inches of shock absorbent material (do not use popcorn-type material for packaging), and clearly mark the RMA on the outside of the shipping container.

NOTE:

Returns must be prepaid and insured. Alpha **does not** accept COD and freight collect. Alpha Technologies **does not** assume responsibility for damage caused by improper packing of returned units.

4.3 Parts and Ordering Information

4.3.1 Ordering

To find additional information about Alpha products, services, and office locations, go to: www.alpha.com.

To order parts, contact the Alpha Technologies Customer Service Department directly

Latin America:	+1-360-647-2360
Germany	+49-9122-79889-0
Australia:	+61-2-9894-7866
United Kingdom	+44 1279-501110
Middle East	+357-25-375675
China:	+86-10-8462-6760
Asia except China	+1-360-647-2360

To obtain **emergency** technical support (7 days/week, 24 hours/day) call:

+49-9122-79889-0
(Western/Eastern Europe)

+86-10-8462-6760
(China)

+1-360-647-2460
(U.S.)

4.0 Troubleshooting and Repair, *continued*

4.3.2 Replacement Parts:

The following parts can be replaced in the field and are available from Alpha Technologies. To order parts, please specify the model number that appears on the nameplate, and contact your nearest Alpha sales office.

Alpha Part No.	Type	Description
210-050-86	Capacitor	Oil Filled 12.5 μ F; 660 VAC
210-051-86	Capacitor	Oil Filled 17.5 μ F; 660 VAC
460-275-86	Fuses	Slow Blow 5mmx20.5mm; 5 amp
460-276-86	Fuses	Slow Blow 5mmx20.5mm; 8 amp
460-281-86	Fuses	Slow Blow 5mmx20.5mm; 15 amp

4.4 Alpha APX2-G System Schematic

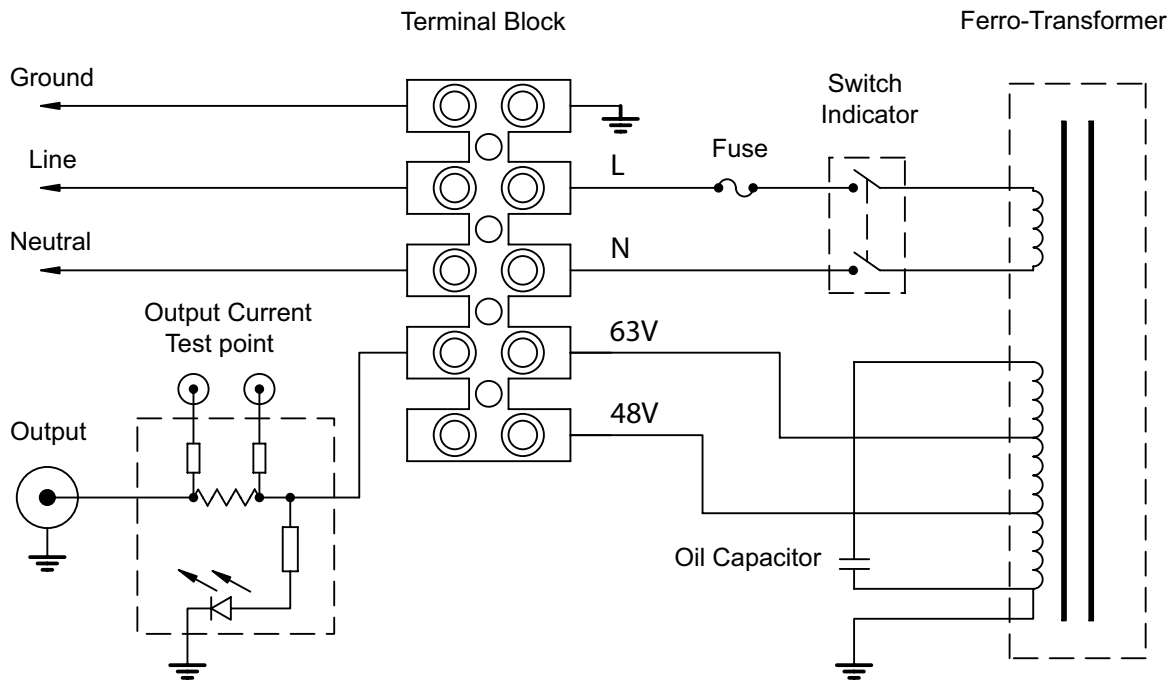

Fig. 4-1, Alpha APX2-G Schematic

22.90cm

11.40cm

Mounting Template

Mark the holes and position drill according to the mounting hardware.

Remove the black plastic plugs in order to tighten the mounting hardware. Please replace the plugs after tightening hardware.

Alpha Technologies Power

Alpha Technologies
3767 Alpha Way
Bellingham, WA 98226
USA
Tel: +1 (360) 647-2360
Fax: +1 (360) 671-4936
Web: www.alpha.com

Alpha Technologies Ltd.
4084 McConnell Court
Burnaby, BC, V5A 3N7
CANADA
Tel: +1 (604) 430-1476
Fax: +1 (604) 430-8908

Alpha Technologies
Europe Ltd.
Twyford House
Thorley
Bishop's Stortford
Hertfordshire
CM22 7PA
UNITED KINGDOM
Tel: +44 1279-501110
Fax: +44 1279-659870

Alpha Technologies GmbH
Hansastraße 8
D-91126 Schwabach
GERMANY
Tel: +49-9122-79889-0
Fax: +49-9122-79889-21

Alphatec
339 St. Andrews Street
Suite 101
Andrea Chambers
Limassol, Cyprus
CYPRUS
Tel: +357-25-375675
Fax: +357-25-359595

Alpha Technologies
Unit 6, 8 Anella Ave.
Castle Hill, NSW 2154
AUSTRALIA
Tel: +61-2-9894-7866
Fax: +61-2-9894-0234