

Fiber Backhaul Enclosure



Fiber Backhaul Enclosure (FBE) Installation Manual *Effective: July 2009*

Power

Alpha Technologies

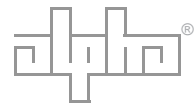

Fiber Backhaul Enclosure Installation Manual

021-081-B0-001, Rev. A
Effective Date: July, 2009
Copyright© 2009
Alpha Technologies, Inc.

member of The  Group™



NOTE:

Alpha denies responsibility for any damage or injury involving its enclosures, power supplies, generators, batteries or other hardware, manufactured by Alpha or members of the Alpha Group, when used for an unintended purpose, installed or operated in an unapproved manner, or improperly maintained.



NOTE:

Photographs and drawings contained in this manual are only for illustrative purposes. These photographs and drawings may not exactly match your installation.



NOTE:

Review the written and illustrative information contained in this manual before proceeding. If there are questions regarding the safe installation or operation of this product, please contact Alpha Technologies or your nearest Alpha representative.

Contacting Alpha Technologies: *www.alpha.com*

OR

For general product information and customer service (7 AM to 5 PM, Pacific Time), call

1-800-863-3930

For complete technical support, call

1-800-863-3364

7 AM to 5 PM, Pacific Time or 24/7 emergency support

Table of Contents

Safety Information	5
1.0 Introduction.....	8
1.1 Fiber Backhaul Enclosure.....	8
1.2 Fiber Backhaul Enclosure (FBE) Specifications	10
1.3 Parts List.....	11
2.0 Installation.....	12
2.1 Lifting	12
2.2 Enclosure Installation, H-Bracket.....	15
2.3 Connecting Utility Power.....	16
2.4 Enclosure Cooling.....	17
2.5 Cabinet Air Filtration.....	17

Figures & Tables

Fig. 1-1 Fiber Backhaul Enclosure	8
Fig. 1-2 Fiber Backhaul Enclosure (open).....	9
Fig. 2-1 Enclosure Lifting Arrangement.....	12
Fig. 2-2 Enclosure Dimensions (Without Battery Cabinet)	13
Fig. 2-3 Enclosure Dimensions (With Battery Cabinet)	13
Fig. 2-4 Enclosure Dimensions cont'd.....	14
Fig. 2-5 FBE Installation	15
Table 1-1 Specifications	10
Table 1-2 Parts List.....	11

Safety Notes

Review the drawings and illustrations contained in this manual before proceeding. If there are any questions regarding the safe installation or operation of the system, contact Alpha Technologies or the nearest Alpha representative. Save this document for future reference.

To reduce the risk of injury or death, and to ensure the continued safe operation of this product, the following symbols have been placed throughout this manual. Where these symbols appear, use extra care and attention.

ATTENTION

The use of ATTENTION indicates specific regulatory/code requirements that may affect the placement of equipment and /or installation procedures.



NOTE:

A NOTE provides additional information to help complete a specific task or procedure.



CAUTION!

The use of CAUTION indicates safety information intended to PREVENT DAMAGE to material or equipment.



WARNING!

WARNING presents safety information to PREVENT INJURY OR DEATH to the technician or user.

Battery Maintenance Guidelines

The battery maintenance instructions listed below are for reference only. Battery manufacturer's instructions for transportation, installation, storage or maintenance take precedence over these instructions.

- To prevent damage, inspect batteries every 3 months for:
 - **Signs of battery cracking, leaking or swelling.** The battery should be replaced immediately by authorized personnel using a battery of the identical type and rating.
 - **Signs of battery cable damage.** Battery cable should be replaced immediately by Authorized Personnel using replacement parts specified by vendor.
 - **Loose battery connection hardware.** Refer to battery manufacturer's documentation for the correct torque and connection hardware for the application.
- Apply battery manufacturer's specified antioxidant compound on all exposed connections.
- Verify battery terminals and/or exposed connection hardware is not within 2 inches of a conductive surface. Reposition batteries as necessary to maintain adequate clearance.
- Clean up any electrolyte (battery emission) in accordance with all federal, state, and local regulations or codes.
- Proper venting of the enclosure is recommended. Follow the Battery Manufacturer's approved transportation and storage instructions.
- Always replace batteries with those of an identical type and rating. Never install old or untested batteries.
- Do not charge batteries in a sealed container. Each individual battery should have at least 0.5 inches of space between it and all surrounding surfaces to allow for convection cooling.
- All battery compartments must have adequate ventilation to prevent an accumulation of potentially dangerous gas.

Recycling and Disposal Instructions

Spent or damaged batteries are considered environmentally unsafe. Always recycle used batteries or dispose of the batteries in accordance with all federal, state and local regulations.

Electrical Safety

- Lethal voltages are present within the power supply and electrical boxes. Never assume that an electrical connection or conductor is not energized. Check the circuit with a volt meter with respect to the grounded portion of the enclosure (both AC and DC) prior to any installation or removal procedure.
- Always use the buddy system when working under hazardous conditions.
- A licensed electrician is required to install permanently wired equipment.
- Input voltages can range up to 240 Vac. Ensure that utility power is disabled before beginning installation or removal.
- Ensure no liquids or wet clothes contact internal components.
- Hazardous electrically live parts inside this unit are energized from batteries even when the AC input power is disconnected.

Mechanical Safety

- Keep hands and tools clear of fans. Fans are thermostatically controlled and will turn on automatically.
- Power supplies can reach extreme temperatures under load.
- Use caution around sheet metal components and sharp edges.

Battery Safety Notes

WARNING!

Lead-acid batteries contain dangerous voltages, currents and corrosive material. Battery installation, maintenance, service and replacement must be performed only by authorized personnel.

Chemical Hazards

Any gelled or liquid emissions from a valve-regulated lead-acid (VRLA) battery contain dilute sulfuric acid, which is harmful to the skin and eyes. Emissions are electrolytic, and are electrically conductive and corrosive.

To avoid injury:

- Servicing and connection of batteries shall be performed by, or under the direct supervision of, personnel knowledgeable of batteries and the required safety precautions.
- Always wear eye protection, rubber gloves, and a protective vest when working near batteries. Remove all metallic objects from hands and neck.
- Batteries produce explosive gases. Keep all open flames and sparks away from batteries.
- Use tools with insulated handles, do not rest any tools on top of batteries.
- Batteries contain or emit chemicals known to the State of California to cause cancer and birth defects or other reproductive harm. Battery post terminals and related accessories contain lead and lead compounds. Wash hands after handling (California Proposition 65).
- Wear protective clothing (insulated gloves, eye protection, etc.) whenever installing, maintaining, servicing, or replacing batteries.
- If any battery emission contacts the skin, wash immediately and thoroughly with water. Follow your company's approved chemical exposure procedures.
- Neutralize any spilled battery emission with the special solution contained in an approved spill kit or with a solution of one pound Bicarbonate of soda to one gallon of water. Report chemical spill using your company's spill reporting structure and seek medical attention if necessary.
- All battery compartments must have adequate ventilation to prevent an accumulation of potentially dangerous gas.
- Prior to handling the batteries, touch a grounded metal object to dissipate any static charge that may have developed on your body.
- Never use uninsulated tools or other conductive materials when installing, maintaining, servicing or replacing batteries.
- Use special caution when connecting or adjusting battery cabling. An improperly connected battery cable or an unconnected battery cable can make contact with an unintended surface that can result in arcing, fire, or possible explosion.

1.0 Introduction

1.1 Fiber Backhaul Enclosure

Alpha's new Fiber Backhaul Enclosure is engineered to house optical fiber equipment to support high speed cellular data backhaul. Built with eleven rackmount spaces, the Alpha FBE is able to house fiber and powering gear including an Ethernet switch, power inverters, rectifiers, fiber splice tray, GMT and additional controls. Optional configurations enable the addition of Batteries, DC rectifiers and a Service Utility Entrance. With Telecom-grade, padlockable quarter-turn locks and Demark access, the FBE offers easy maintenance access and complete security.



NOTE:

For Fiber Backhaul Enclosure wiring diagrams and alarm information, see *Fiber Backhaul Enclosure System Schematics*, Alpha P/N 021-081-08.



Figure 1-1, Fiber Backhaul Enclosure



Figure 1-2, Fiber Backhaul Enclosure (open)

1.0 Introduction

1.2 Fiber Backhaul Enclosure (FBE) Specifications

Fiber Backhaul Enclosure		
Material:	Aluminum	
Exterior Finish:	Powdercoated exterior	
Exterior hardware:	Stainless Steel	
Interior hardware:	Stainless Steel and/or Zinc plated	
Mechanical		
Dimensions (maximum)	Fiber Backhaul Enclosure	Fiber Backhaul Enclosure (with Battery Cabinet)
Width (in/mm):	23/584	23/584
Height (in/mm):	27/686	41/1041
Depth (in/mm):	22.3/565	22.3/565
Weight (lbs/kg):	57/26	82/37.5
Enclosure External Mounting:	Wall or H-bracket	
Enclosure Internal Mounting:	Adjustable (front to back) 19" equipment rack. 11RU with maximum equipment depth of 15", up to 17" without optional din rail and ground bar	
Door(s):	Front: Hinged, with quarter-turn Telecom-grade locks Demark/craft access - 2RU in height for eight RJ45 connectors with surge protection and two LGX fiber connector panels	
Knockouts:	2 x 2", 2 x 1.5", 4 x 0.75"	
Environmental		
Cooling:	Redundant fans; 24 or 48Vdc, ball bearing, sealed, >70,000hr MTBF	
Solar Insulation:	3/16" foil blanket (minimum)	
Vent/Bug Screen:	20x20 mesh	
Operating Temperature:	-40° to 120°F/-40° to 49°C	
Safety		
Agency Standards:	CSA	CSA C22.2 No 60950-01-07; 60950-22-07
	UL	UL 60950-1; UL 60950-22-2007
	Cabinet	NEMA Type 3R
Optional Service Entrance:	SUSE rated	
Grounding:	Permanent chassis ground for #6AWG wire	

* "Information Technology Equipment Safety"

Table 1-1, FBE Specifications

1.3 Parts List

Enclosure Components	
Description	Part Number
Enclosure Assembly, FBE	031-296-20
Optional Components	
Description	Part Number
Temperature alarm switch	171-005-10
Din rail, accessory mounting	605-752-A1-001
Fan controller, 24Vdc	704-696-31
Enclosure Lifting Kit	744-941-25
Fan tray assembly, 24Vdc	746-062-21
Enclosure tamper switch kit	746-064-20
GMT style fuse panel, 24Vdc	746-065-20
Spare Components	
Description	Part Number
Tamper Switch	424-050-19
GMT Fuse, 10A	460-069-10
GMT Fuse, 5A	460-084-10
Replacement Fan (pair), 24Vdc	746-072-20
Electrostatic Air Filter	565-151-10

Table 1-2, Parts List

2.0 Installation

2.1 Lifting

Attach the lifting chain to the eyebolts located in the top of the enclosure. Verify the adjustable chain links are tightened securely. Also verify the length of the cable between the eyebolts and the lifting hook (2d) is at least twice the distance (d) between the lifting eyebolts and the lifting angle of the chain is greater than or equal to 60 degrees.



NOTE:

Remove the lifting ears after installation. The ears are made of steel and may rust over time.



WARNING!

Do not allow personnel to walk beneath the suspended unit during the lifting operation. Use steel-toe work shoe protection. Use "hard hats" at all times during this procedure.



CAUTION!

Do not lift the enclosure with the equipment or batteries in place. Ensure load capacity of lifting equipment is rated for the weight of the Fiber Backhaul Enclosure.

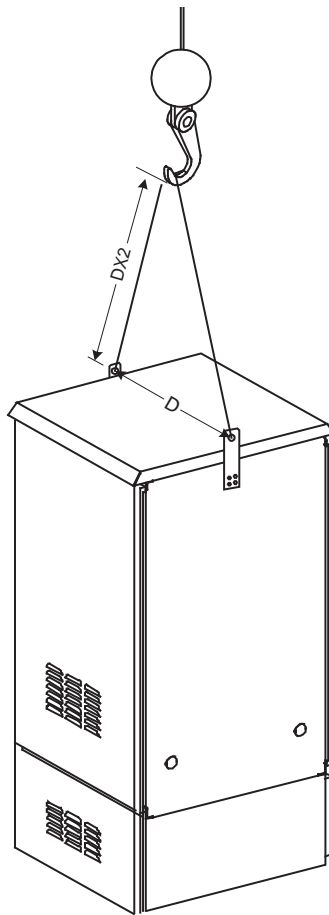

Fig. 2-1, Enclosure Lifting Arrangement

2.2 Enclosure Installation, H-Bracket

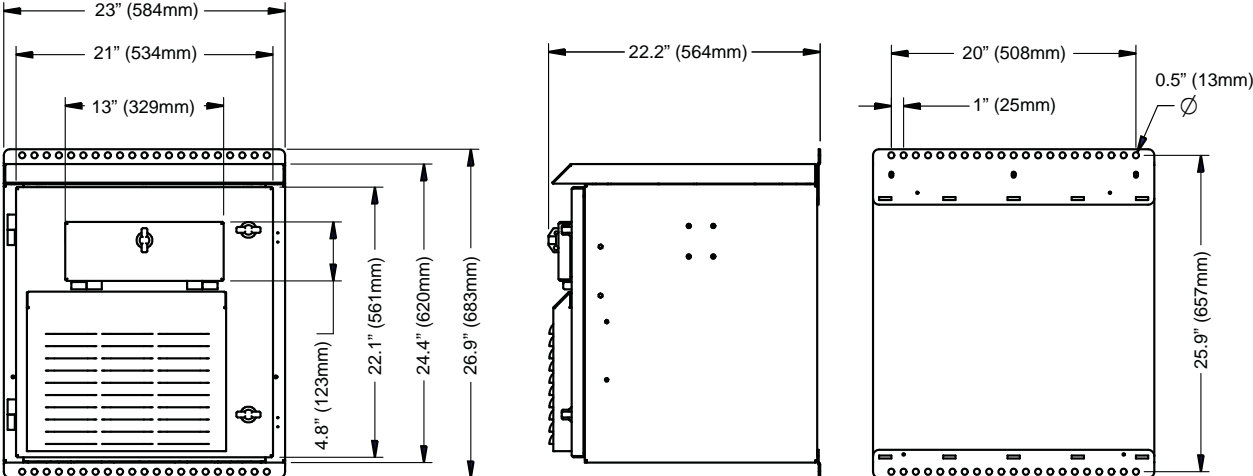

Figure 2-2, Enclosure Dimensions (without battery cabinet)

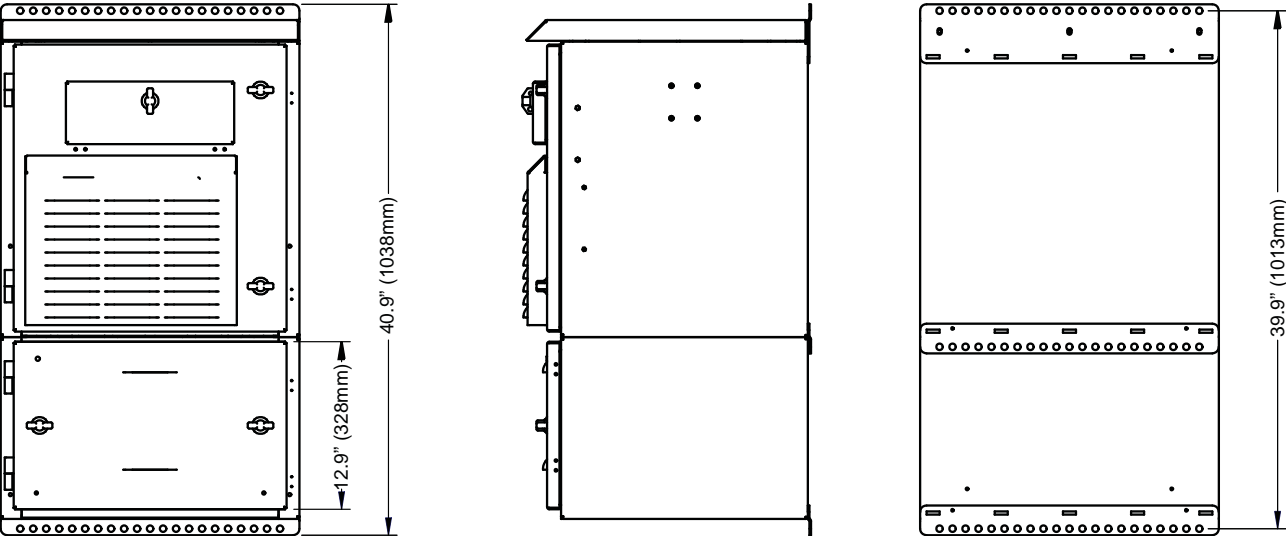
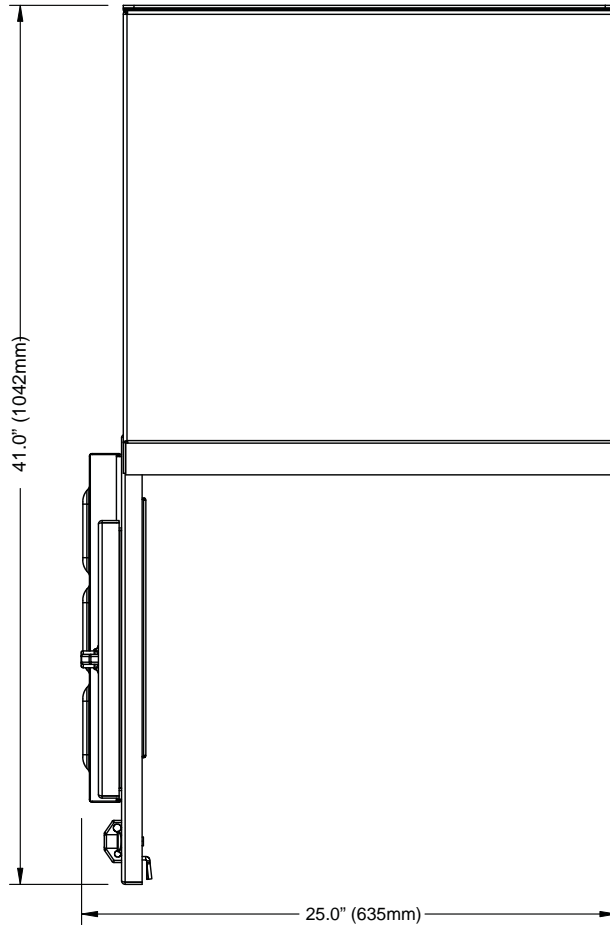

Figure 2-3, Enclosure Dimensions (with Battery Cabinet)

2.2 Enclosure Installation, H-Bracket (continued)



Notes:

- 1) Standard FBE units are equipped with Left-hand opening doors. Right-hand opening doors are available as an option.
- 2) Maximum equipment depth for standard configuration is 15" (380mm). If optional DIN rail and ground bar are not required, the EIA rails may be moved forward to increase maximum depth to 17" (432mm).

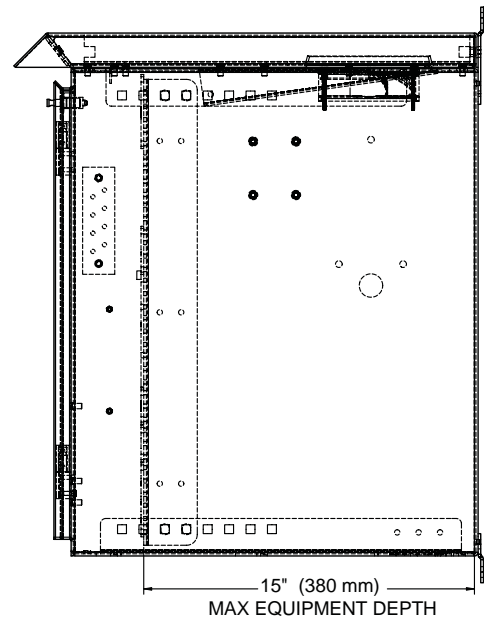
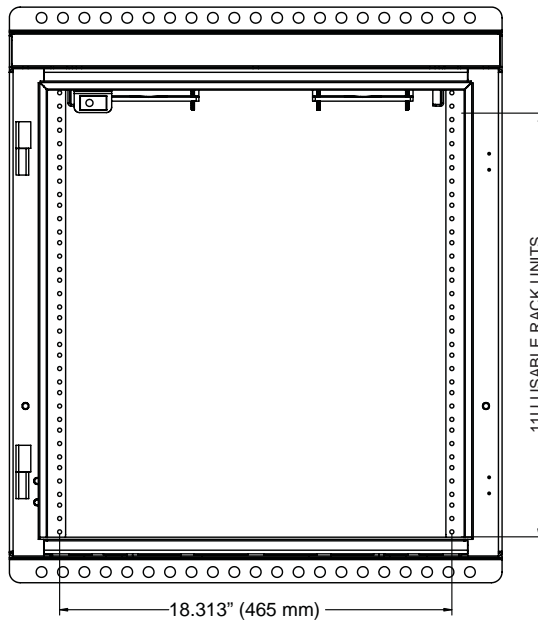

Figure 2-4, Enclosure Dimensions cont'd

2.2 Enclosure Installation, H-Bracket (continued)

Most codes require the base of the enclosure to be located a minimum height from the ground. Always verify height restrictions before proceeding.

Recommended Tools and Materials:

- Ratchet with 5/8" (19mm) socket
- Level
- 7/16" x 1" (M12 x 25) hex head stainless steel bolts (quantity 4)
- 1" (25.4mm) diameter (minimum 0.1"/2.5mm thick) stainless steel flat washer for 7/16" (M12) bolt (quantity 4)
- Stainless steel helical lock washer for 7/16" (M12) bolt (quantity 4)
- Lifting kit (optional)

Installation Procedure:

1. Position the enclosure on an H-Bracket capable of supporting 350lbs (160kg).
2. The optional lifting ears may be used to raise and position the empty enclosure.
3. Using a level, ensure that the enclosure base is parallel to the ground.
4. Secure the enclosure to the H-Bracket using four user-supplied 7/16" x 1" (M12 x 25) hex head stainless steel bolts, helical lock washers and flat washers.

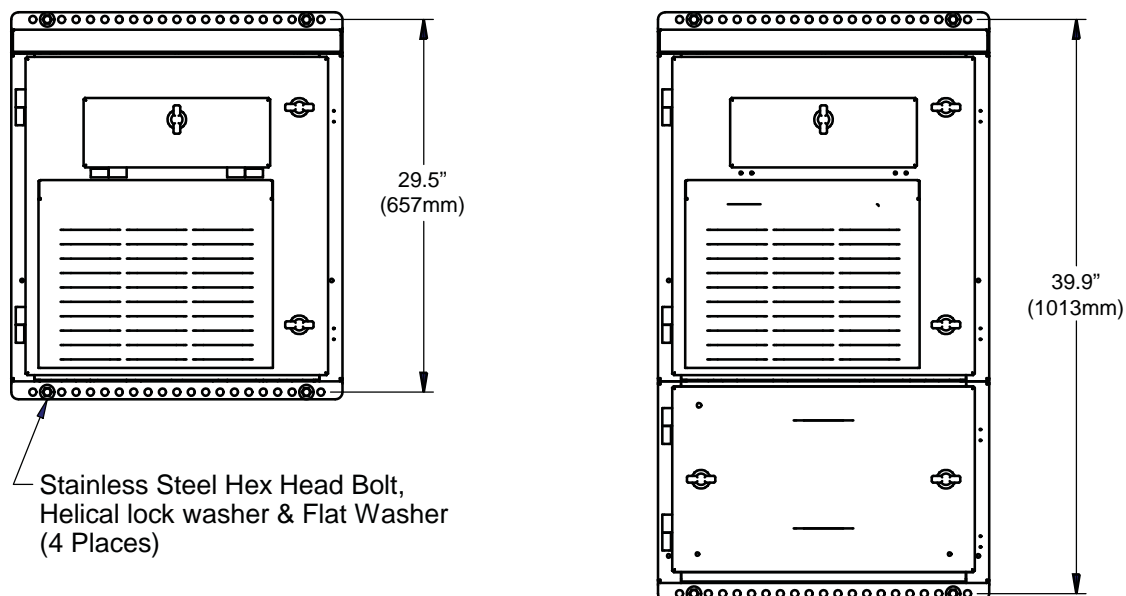

Figure 2-5, FBE Installation

2.0 Installation

2.3 Connecting Utility Power



WARNING!

ONLY qualified personnel should connect the utility power. Power must be connected in compliance with local electrical codes, and common safety practices must be observed.

ATTENTION:

- Connection to utility power may need to be approved by the local utility before installing the enclosure.
- Your local authority may require that a service disconnect switch (UL listed) be provided by the installer and be connected between the power source and the enclosure.



WARNING!

Low impedance grounding is **mandatory for personnel safety** and critical for the proper operation of the cable system .

Strike (Lightning) Ground

Lightning strikes, grid switching, or other aberrations on the power line and/or communications cable have the potential to cause high-energy transients which can damage the powering or communications systems. Without a low-impedance path to ground, the current, when traveling through wires of varying impedance, produce damaging high voltage. The most viable method available to protect the system from damage is to divert these unwanted high-energy transients along a low-impedance path to ground. A low-impedance path to ground prevents these currents from reaching high voltage levels and posing a threat to equipment. The single-point grounding system provides a low-impedance path to ground, and the key to its success is the proper bonding of the ground rods, so the components of the grounding system appear as a single point of uniform impedance. Alpha recommends the use of a surge arresting device electrically bonded to the grounding system.



NOTE:

All ground rod connections must be made by means of a listed grounding clamp suitable for direct burial or exothermically welded.

2.4 Enclosure Cooling

 **NOTE:**

Consultation with Alpha Applications Engineering is required. Provisions must be made for adequate air flow in the cabinet, equipment total heat dissipation load inside the cabinet, equipment min/max operating temperatures, equipment over-temp fail safe shutdown capability, environmental outdoor design conditions, and battery back up run times.

- Cooling capacity 200W dissipated with 10°C rise over ambient.
- Two 100 CFM fans with variable speed temperature control.
- Fans are off below 25°C. Fans increase from 40% to 100% with increased enclosure temperature from 25°C to 45°C. Power to the Fan Control PCBA must be provided by a circuit breaker or fuse. 5A recommended; 10A maximum.
- Form C dry contact alarm, fan fail, open on alarm.
- Maximum power draw 23W.

2.5 Cabinet Air Filtration

The system has an electrostatic filter that should be inspected for cleaning or replacement every six months depending on time of year or environment. Clean the filters by back flushing with water in the direction indicated and reinstall the filter with air flow direction pointing into the enclosure and drain holes at the bottom.

 **NOTE:**

Some environments may require more frequent inspections to maintain optimum airflow.

2.0 Installation

Power

Alpha Technologies 

Alpha Technologies
3767 Alpha Way
Bellingham, WA 98226
USA
Tel: +1(360) 647-2360
Fax: +1(360) 671-4936
Web: www.alpha.com

Alpha Technologies Ltd.
4084 McConnell Court
Burnaby, BC, V5A 3N7
CANADA
Tel: +1(604) 430-1476
Fax: +1(604) 430-8908

Alpha Technologies
Europe Ltd.
Twyford House
Thorley
Bishop's Stortford
Hertfordshire
CM22 7PA
UNITED KINGDOM
Tel: +44 1279-501110
Fax: +44 1279-659870

Alpha Technologies GmbH
Hansastraße 8
D-91126 Schwabach
GERMANY
Tel: +49-9122-79889-0
Fax: +49-9122-79889-21

Alphatec, Ltd
P.O. Box 56468
Limassol, Cyprus
CYPRUS
Tel: +357-25-375675
Fax: +357-25-359595

Alpha Technologies France
34, Grande Rue
Bétheny, F-51450
FRANCE
Phone: +33 32 64990 54
Fax: +33 95 60205 01