

P45 Series Battery Charger



Operating Manual
Effective: April, 2006

Alpha Technologies ®

Power

P45 Series Charger

Operation Manual

031-186-B1-001, Rev. A

Effective Date: April, 2006

Copyright © 2006

Alpha Technologies, Inc.

member of The  Group™



NOTE:

The technical data and specifications in this document provided courtesy of MTI Technologies and have not been verified by Alpha Technologies.



NOTE:

Photographs contained in this manual are for illustrative purposes only. These photographs may not match your installation.



NOTE:

Operator is cautioned to review the drawings and illustrations contained in this manual before proceeding. If there are questions regarding the safe operation of this powering system, please contact Alpha Technologies or your nearest Alpha representative.



NOTE:

Alpha shall not be held liable for any damage or injury involving its enclosures, power supplies, generators, batteries, or other hardware if used or operated in any manner or subject to any condition not consistent with its intended purpose, or is installed or operated in an unapproved manner, or improperly maintained.

Contacting Alpha Technologies: *www.alpha.com*

or

For general product information and customer service (7 AM to 5 PM, Pacific Time), call

1-800-863-3930

For complete technical support, call

1-800-863-3364

7 AM to 5 PM, Pacific Time and 24/7 emergency support

TABLE OF CONTENTS

IMPORTANT SAFETY INSTRUCTIONS.....	5
INTRODUCTION.....	9
INSTALLATION.....	10
PLACEMENT.....	10
VENTILATION AND COOLING	10
ELECTRICAL CONNECTION AND WIRING.....	11
POWER UP	11
SYSTEM POWER OFF PROCEDURE	11
THEORY OF OPERATION.....	12
DISPLAY SCREEN AND KEYPAD	13
DISPLAY SCREEN.....	13
Keypad:	13
Fixed charger mode:.....	13
Display unit.....	13
ACCESSING MENU VIA KEYPAD; OVERVIEW.....	14
MENU STRUCTURE QUICK OVERVIEW.....	15
MENU DETAILED FUNCTIONS.....	18
MAIN MENU.....	18
Equalize.....	18
LCD Contrast.....	18
Reset alarms and relays (available in case of alarm only)	19
Adjust	19
Control	19
Alarms	20
Level 2 (strict level).....	22
Readings	23
MODBUS (OPTIONAL)	24
MATERIAL CONFIGURATION	24
RAM MEMORY MAP.....	24
1.1 Format for voltage and current values	25
1.2 Logic of alarms.....	26
1.3 Float/Equalize	26
1.4 Reset Alarm.....	27
TROUBLE SHOOTING	28
REGULAR PREVENTIVE MAINTENANCE	29
CONTROL BOARD (PC) - ADJUSTMENT PROCEDURE.....	30
EXAMPLE.....	30
Procedure.....	31
ALARMS ADJUSTMENT PROCEDURE.....	32
EXAMPLE.....	32
Procedure.....	32

Safety Notes

Review the drawings and illustrations contained in this manual before proceeding. If there are any questions regarding the safe installation or operation of the system, contact Alpha Technologies or the nearest Alpha representative. Save this document for future reference.

To reduce the risk of injury or death, and to ensure the continued safe operation of this product, the following symbols have been placed throughout this manual. Where these symbols appear, use extra care and attention.

ATTENTION:

The use of ATTENTION indicates specific regulatory/code requirements that may affect the placement of equipment and /or installation procedures.



NOTE:

A NOTE provides additional information to help complete a specific task or procedure.



CAUTION!

The use of CAUTION indicates safety information intended to PREVENT DAMAGE to material or equipment.



WARNING!

A WARNING presents safety information to PREVENT INJURY OR DEATH to the technician or user.

Safety Precautions

- Only qualified personnel may service the system.
- Verify the voltage requirements of the equipment to be protected (load), the AC input voltage to the power supply (line), and the output voltage of the system prior to installation.
- Verify the utility service panel is equipped with a properly rated circuit breaker for use with this system.
- When connecting the load, DO NOT exceed the output rating of the power supply.

Recycling and Disposal Instructions

Spent or damaged batteries are considered environmentally unsafe. Always recycle used batteries or dispose of the batteries in accordance with all federal, state and local regulations.

Electrical Safety

- Lethal voltages are present within the power supply and electrical boxes. Never assume that an electrical connection or conductor is not energized. Check the circuit with a volt meter with respect to the grounded portion of the enclosure (both AC and DC) prior to any installation or removal procedure.
- Always use the buddy system when working under hazardous conditions.
- A licensed electrician is required to install permanently wired equipment.
- Input voltages can range up to 600 VAC. Ensure that utility power is disabled before beginning installation or removal.
- Ensure no liquids or wet clothes contact internal components.
- Hazardous electrically live parts inside this unit are energized from batteries and capacitors even when the AC input power is disconnected.
- AC and DC currents are present in this system even with the indicators and circuit breakers in the OFF position.

Mechanical Safety

- Keep hands and tools clear of fans. Fans (if equipped) are thermostatically controlled and will turn on automatically.
- Power supplies can reach extreme temperatures under load.
- Use caution around sheet metal components and sharp edges.

Introduction

Thank you for having chosen Alpha Industrial Power. The P45 series battery charger is designed to provide quality DC power for many years.

This user's manual contains important technical instructions to be followed by qualified personnel responsible for the installation, start-up and maintenance of this unit. We recommend that this manual be read closely to ensure safe and reliable operation of this equipment.

NOTE:

Upon receipt, inspect the unit for shipping damage. Verify any wire connections have not become loose or disconnected during transportation. Do not install unit until receiving inspection has been completed.

Installation

Placement:

FOR INSTALLATION, PLEASE REFER TO NATIONAL AND LOCAL ELECTRICAL CODES.

The system is very heavy equipment. To prevent personal injury or equipment damage, use lifts and extreme care when handling.

Ventilation and cooling:

The rectifier/charger is rated to better perform within 14°F (−10°C) and 122°F (+50°C) temperature range.

To calculate the required air displacement (exchange) volume, please use the following equation:

$$V = \text{BTU} \times e (0.125 \times H \times T_k / T_o) / (T_r - T_k)$$

V = air flow: [cubic meter/hour]

BTU = Total dissipated heat

T_r = Maximum allowed room temperature [°K] {i.e. 50°C = 323°K}

T_k = Temperature of input cooling air

T_o = 273°K

H = Altitude [km]

Avoid placing the system in direct sunlight.

NOTE:

To ensure adequate ventilation and safe access make sure that the following clearances are respected:

- 3 in. (10 cm) on the sides and top
- 3 feet (1 meter) in front of the unit.

Should seismic conditions require a more secure installation the unit may be bolted to the floor. Four (4) holes are provided for this purpose.

Installation, *continued*

Electrical connection and wiring

Before Connecting the P45 battery charger verify the following:

- The battery breaker is disconnected (if applicable)
- All the circuit breakers are OFF
- The relays, fuses and circuit boards are installed
- The unit is wired in accordance with the instructions (refer to the wiring connections and electrical diagram)

Wire size is very important. The nameplate provides the essential information regarding the input and output voltages and currents.

Refer to your Local or National Electrical Code (NEC) for WIRE GAUGE and GROUNDING instructions.



NOTE:

Use appropriate gauge wire for current load.
Correct voltage and polarity are of critical importance. Check all connections for tightness and polarity.
When connecting batteries, observe correct polarities.

Power up

After all wire installation has been completed and double checked, the unit may be powered up as follows:

- Before connecting the load to the charger, compare the critical characteristics of the load with the critical characteristics of the charger (i.e. measure line-neutral voltage, positive-neutral voltage).
- Keep a log of manipulations (i.e. V_{FLOAT} and V_{EQUALIZE} values entered, alarm messages, alarm and SCR blinking LEDs).
- All input and output breakers must be in **OFF** position.
- Apply power to the equipment from the source panel.
- Turn on AC breaker (**ON** position).
- Turn on DC breaker (if supplied) (**ON** position).
- Green LED must turn **ON**.
- Wait 5 seconds until the indication screen (**LCD**) indicates the system output voltage and status.
- The system soft starts by increasing the output current and the voltage.

If readings or calibration of the unit is necessary, refer to the field programming section for more information.

System power Off procedure

- Open the AC breaker (OFF position).
- Open the DC breaker (if supplied) (OFF position).
- Open the source panel's AC breaker (OFF position).
- If work inside the unit has to be performed, wait 5 minutes to discharge the filter capacitors or use bleeding resistors of the correct rating to discharge the capacitors.

Upon completion of this procedure, the system can be considered de-energized.

Theory of operation

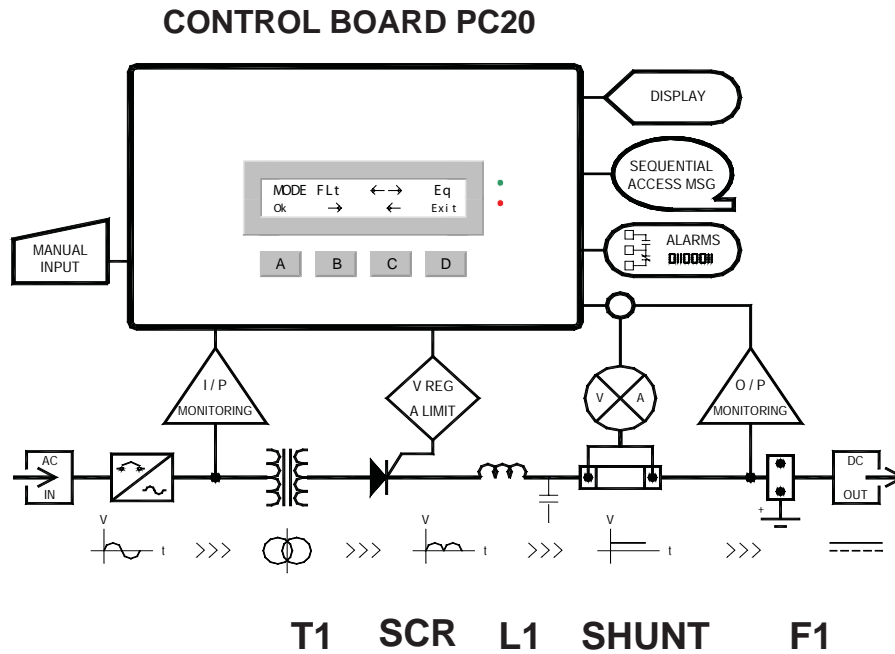

T1 — The AC supply is transformed and isolated.

SCR — The transformer secondary voltage is rectified by a full-wave, half-controlled bridge.

L1, C1 (optional) — The rectified DC voltage is smoothed by LC filter section.

Shunt — Current and voltage reading sent to the control board

F1 — A fuse protects the SCRs and diodes.

Control Board — The PC20 series control board provides automatic charge control, precise voltage regulation, alarm status annunciation and display.

Display Screen and Keypad

Display Screen

The P45 series provides a very flexible and friendly user interface. The display supplied with the standard unit's features a high visibility, back light LCD display.

Keypad

The P4500 uses four (4) long life membrane switches.

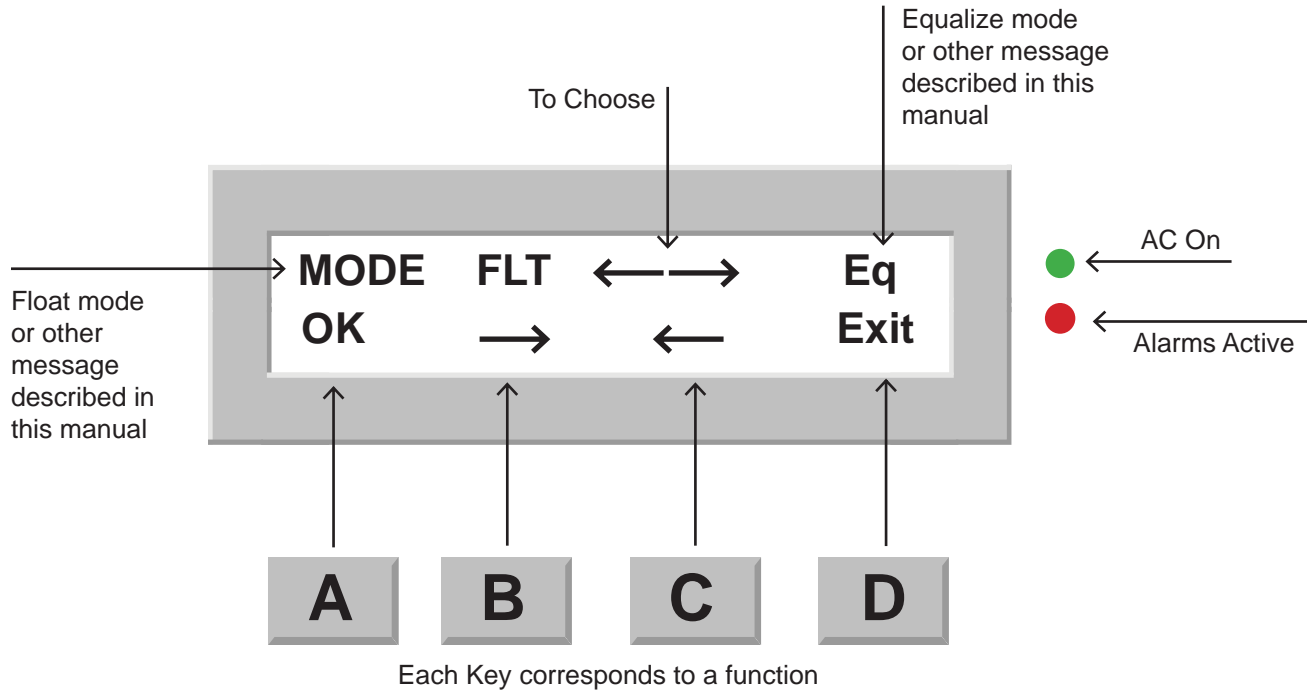

Fixed charger mode

Display unit

- Adjustable values are displayed on the higher row of the LCD, i.e. number of relays, alarm ON/OFF, voltage level.
- Key functions are displayed on the lower row, depending of the menu context.
- When an alarm is active on the charger the exact failure message is appears and the red LED blinks to warn the user.
- In case of multiple alarms the P45 display unit will show sequentially all the warning messages.
- There is also an AC sector detection LED (green LED).
- The user is able to save parameters individually.
- LCD power save feature shuts down the display unit after 5 minutes of keyboard inactivity. When the P45 enters power save mode it saves the latest values entered. Upon wake-up, the P45 returns to the main menu.
- The display accuracy is $\pm 2\%$, ± 1 digit.

Accessing menu via keypad; overview

On power-up the following reading appears on the screen (example).

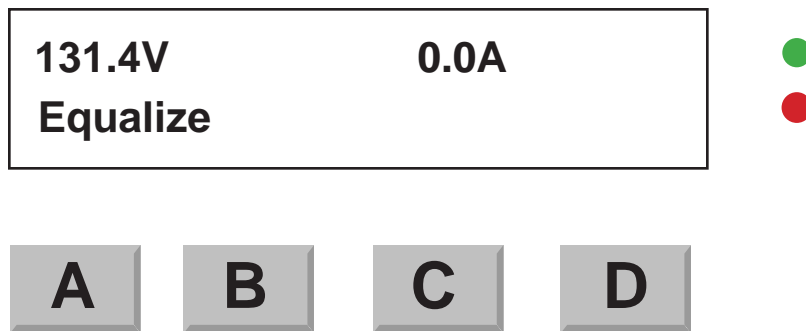

From that point, if you press any key, A to D (only once), you reach the menu screen.

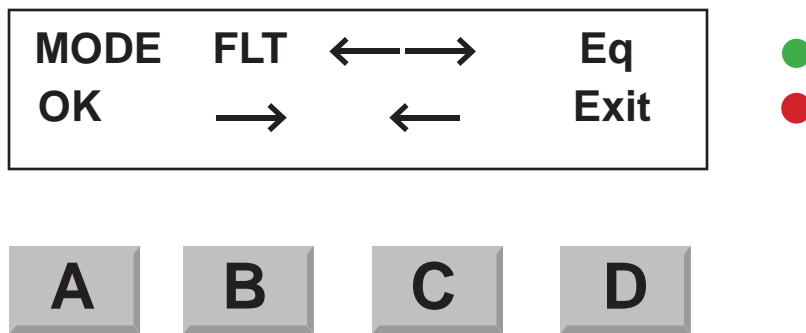

Press **A** (OK), to access the Float / Equalize menu. Press **D** (Exit) to step back to the menu screen.

From the menu, you may reach the different functions by pressing **B**(→).

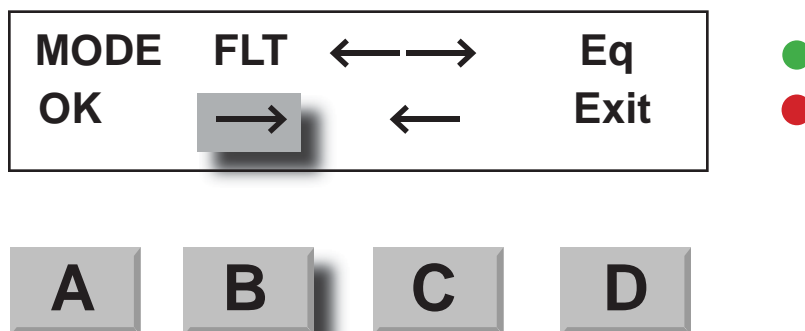

...after one touch of the B (→) key, you get the first function "Adjust".

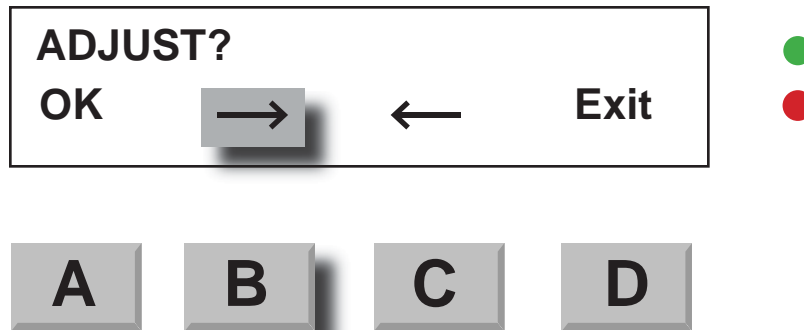

Continuing pressing B (→) will make the screen successively scroll through the following functions:

- Reset Alarm ? (present only in case of alarm)
- Adjust?
- Reading?
- Relay test?
- Contrast LCD

Pressing C (←), 4 times, will make the screen scroll in the opposite direction, back to the initial menu screen.

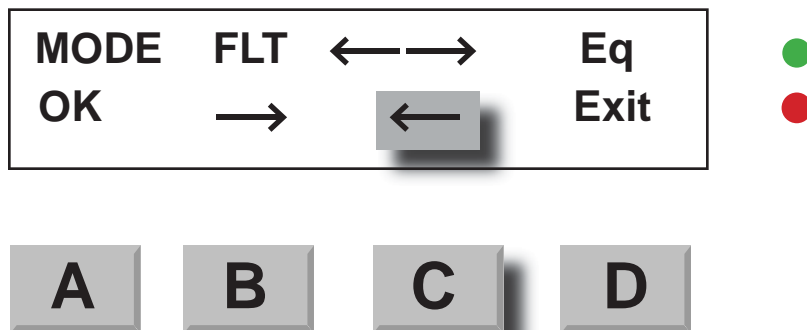

Each function has many sub-functions represented by the following tree structure.

Menu structure quick overview

(some of the menu items may be not applicable for your order)

From the previous menu screen, press B

B (→) Reset Alarm? (visible only in case of alarm)

B (→) Adjust?

A (Ok)

Enter Password (contact AIP for password of this level 2 access)



WARNING!

Modifications to the following settings affect output voltage and output current of the charger and should be done only by qualified technician.

...Control?

A (Ok)

Float 124.9 (for example)

B (→) I Lim 23.3A

Eq	131.5	On	
TEQ	08 H		*
LVEQ	106.1V	On	*
TALimEq	05mn	On	*
AC Eq		On	*
T Float	30 D		*

(*) available only if Eq is "On"

B (→) ...Alarm?

A (Ok)

Talarm 10 S (for example)

B (→) HVAL 138.1V On

... HVSH 90.2V Off

L VAL 100.0V On

L Vdis 61.5V On

GNDF- 5.0mA Off

GNDF+ 5.0mA Off

AC Fail On

LCD latch Off

Com Al latch Off

Ind Al latch Off

Audio Alarm Off

Mesg latch Off

Rct. fail On

Htemp Off

H Ext T 100C Off

L Ext T 00C Off

ACHV 160.0V Off

ACLV 0.0V Off

Fuse Off

Hi ripple Off

I lim Alarm Off

Eq Alarm Off

Bat. disch Off

Pressing C(←) repetitively will make you scroll back in the menu. Pressing D(Exit) will make you step one level back in the hierarchy of the tree menu.

B(→) **Level2?**
 A (Ok)
Enter Password (contact AIP for password of this level 2 access)



WARNING!

Modifications to the following settings should be done by qualified technician)

	Display Off	Off	(for example)
B(→)	Default value		
...	Nom Volt	150V	
	Nom AMP	25 A	
	DCV cal	132.0V	
	DCA cal	0.0A	
	AC display	Off	*
	ACV cal	78.4V	
	ACA cal	539.5A	
	VMIN	0.0V	
	VMAX	160.0V	
	IMAX	*02.2A	
	Remote V sens	Off	
	Load sharing	Off	
	Tcomp	Off	
	LCD Pwr save	Off	
	Remote EQ	Off	
	AH display	Off	*
	Batt capa	100AH	

(*) affect menu option in **Reading** submenu if set to "ON"

Pressing C(←) repetitively will make you scroll back in the menu. Pressing D(Exit) will make you step one level back in the hierarchy of the tree menu.

B(→) **Reading?**
 A (Ok) :Frequency
 B(→) AC display *
 ... AH meter * (not yet available)
 (*) : must be set "ON" in **Level2** menu, to be visible here



B(→) **Relay test?**
 A (OK) A(Yes) D(No)

B(→) **Contrast LCD**
 Press A (OK) A(Set) D(No)

MENU DETAILED FUNCTIONS

(some of the menu items may be not applicable for your order)

Definition of the 4 keys functions. Display field explains the key function shown on the LCD lower row depending on sub-menu context.

KEY	ACTION	DISPLAY	NOTE
A	“OK” Key	OK	Enter the displayed sub-menu (or Set key for sub-function)
B	Scroll Down sub-menu		Go UP next selection
C	Scroll Up sub-menu		Go DOWN last selection
D	Return to previous menu	Exit	Return last selection

Main menu:

Use → or ← keys to scroll the level 0 sub-menus. **SET** to enter menu.

Equalize

DISPLAY	PRESS	ACTION
Float Equalize Exit	Float Equalize Exit	Set float mode Set Equalize mode Return to main menu

DISPLAY	PRESS	ACTION
Reading	SET	Display frequency, AC display, AH meter

LCD Contrast

DISPLAY	PRESS	ACTION
Contrast LCD	SET + -	Access contrast control Contrast High Contrast Low

Reset alarms and relays: (available in case of alarm only)

DISPLAY	PRESS	ACTION
Reset relays	Yes No	Reset all the relays Go to Reset alarm
Reset Alarm msg (not displayed)	Yes No	Clear all alarms messages Go to Relay test
Relay Test (not displayed)	Yes No	Test all relays Go back one level

Adjust:

Use → or ← keys to scroll the sub-menus. **SET** to enter menu. **EXIT** to return to previous menu.

DISPLAY	PRESS	ACTION
PASSWORD	B-A-C (Push in order) EXIT	Enter Level 1 Return to previous menu Password must be valid to access Control, Alarms and reading sub- menu
Control?	SET	Go to Control adjustments
Alarms?	SET	Go to alarm adjustments
Level2?	SET	Go to level 2sub-menu

Control:

Use → or ← keys to scroll to the Control sub-menus. **SET** to enter menu. **EXIT** to return to previous menu.

DISPLAY	PRESS	ACTION	DEFAULT VALUE
Float	+ or -	Adjust Float Voltage (V)	Vnom x 1.09
I LIM	+ or -	Adjust Current Limit (A)	
Eq	SET + or -	Toggle On/Off Equalization Voltage Adjust Equalization Voltage	On Vnom x 1.12
T eq	+ or -	Adjust Equalization Time (Hour)	
L VEQ	+ or -	Adjust Low Equalization Voltage (V)	Vfloat x 0.85
TA LIM E	+ or -	Adjust Time/Current Limit Equalization (Minute)	5 min
ACEq	SET	Toggle On/Off AC Equalization	On
Tfloat	+ or -	Adjust Float Timing (Days)	28

Alarms

Use **→** or **←** keys to scroll the Alarm sub-menus. **SET** to enter menu. **EXIT** to return to previous menu.

DISPLAY	PRESS	ACTION	DEFAULT VALUE
Talarm	+ or –	Adjust alarm Timing (sec)	10 sec
HVAL relay xxx	+ or – NEXT NEXT, On/Off NEXT, + or –	Adjust High Voltage alarm level (V) Go to Relays selection/toggle menu Toggle On/Off High Voltage alarm Select relays number (1 to 7)	Ve _q x 1.05 On No. 2
HVSH relay xxx	+ or – NEXT NEXT, On/Off NEXT, + or –	Adjust High Voltage Shutdown level (V) Go to Relays selection/toggle menu Toggle High voltage shutdown Select relays number (1 to 7)	Ve _q x 1.1 Off No. 8
LVAL relay xxx	+ or – NEXT NEXT, On/Off NEXT, + or –	Adjust Low Voltage alarm level (V) Go to Relays selection/toggle menu Toggle On/Off Low Voltage alarm Select relays number (1 to 7)	0.8 x V _{float} On No.3
LVDis relay xxx	+ or – NEXT NEXT, On/Off NEXT, + or –	Adjust Low Voltage Disconnect level (V) Go to Relays selection/toggle menu Toggle Low voltage Disconnect Select relays number (1 to 7)	 No. 4
GNDF– relay xxx	+ or – NEXT NEXT, On/Off NEXT, + or –	Adjust Negative Ground Fault level (mA) Go to Relays selection/toggle menu Toggle Negative Ground Fault Select relays number (1 to 7)	5 mA On No. 4
GNDF+ relay xxx	+ or – NEXT NEXT, On/Off NEXT, + or –	Adjust Positive Ground Fault level (mA) Go to Relays selection/toggle menu Toggle Positive Ground Fault Select relays number (1 to 7)	5 mA On No. 4
AC Fail	+ or – NEXT NEXT, On/Off NEXT, + or –	Select relays number (1 to 7) Go to Relays selection/toggle menu Toggle On/Off AC Failure Alarm Select relays number (1 to 7)	 On No.5
Mesg latch	SET	Toggle On/Off Alarm Message Latch	On
LCD latch	Not available		
CAL latch	SET	Toggle On/Off Common Alarm Latch	Off
Ind alm latch	SET	Toggle On/Off Individual Alarm Latch	On
Audio latch	SET	Toggle On/Off Audio Alarm Latch	Off
Mesg latch	SET	Toggle On/Off Alarm Display Latch	On

Alarms, continued

DISPLAY	PRESS	ACTION	DEFAULT VALUE
Rct fail relay xxx	+ or – NEXT NEXT, On/Off NEXT, + or –	Select relays number (1 to 7) Go to Relays selection/toggle menu Toggle On/Off Rectifier Failure alarm Select relays number (1 to 7)	On No.1
H temp	SET + or –	Toggle On/Off High Temperature alarm Select relays number (1 to 7)	On
H ext T relay xxx	+ or – NEXT NEXT, On/Off NEXT, + or –	Adjust High External temperature level Alarm Go to Relays selection/toggle menu Toggle High External temperature level Alarm Select relays number (1 to 7)	
L ext T relay xxx	+ or – NEXT NEXT, On/Off NEXT, + or –	Adjust Low External temperature level Alarm Go to Relays selection/toggle menu Toggle Low External temperature level Alarm Select relays number (1 to 7)	
ACVH relay xxx	+ or – NEXT NEXT, On/Off NEXT, + or –	Adjust High AC Voltage level alarm Go to Relays selection/toggle menu Toggle High AC Voltage Level Alarm Select relays number (1 to 7)	Off
ACVL relay xxx	+ or – NEXT NEXT, On/Off NEXT, + or –	Adjust Low AC Voltage level alarm Go to Relays selection/toggle menu Toggle Low AC Voltage Level Alarm Select relays number (1 to 7)	Off
DC Fuse	SET + or –	Toggle On/Off Fuse alarm Select relays number (1 to 7)	
Hi ripple	SET + or –	Toggle On/Off High Ripple alarm Select relays number (1 to 7)	Off
Ilim Alarm	SET + or –	Toggle On/Off Current Limit alarm Select relays number (1 to 7)	
Eq Alarm	SET + or –	Toggle On/Off Equalize alarm Select relays number (1 to 7)	Off No. 4
Bat, disch	SET + or –	Toggle On/Off Battery Discharge alarm Select relays number (1 to 7)	Off Batt. Current > O/P current

Level 2 (strict level)

Use → or ← keys to scroll the **level 2** sub-menus. SET to enter menu. EXIT to return to previous menu.

DISPLAY	Press	ACTION	Default Value
PASSWORD	Contact AIP EXIT	Enters Level 2 Return to previous menu Password must be valid to access Control, Alarms and reading sub-menu	
Value default	SET	Toggle On/Off Select factory value On/Off	
Display Off	SET	Toggle On/Off When Off, all values are displayed When On, only values that are set to “On” are displayed	
NomVolt	+ or -	Adjust the Nominal Voltage displayed Once values is set Nominal Voltage is not displayed	Factory preset
NomAmp	+ or -	Adjust the Nominal Ampere displayed Once values is set Nominal Ampere is not displayed	Factory preset
DCV cal offset XXX	+ or - NEXT, + or -	Adjust the DC Voltage calibration Adjust the DC Voltage offset	
DCA cal offset XXX	+ or - NEXT, + or -	Adjust the DC Current calibration Adjust the DC Current offset	
AC display	SET	Toggle On/Off AC display	Off
ACV cal	+ or -	Adjust the AC Voltage calibration	
ACA cal		Adjust the AC Current calibration	
VMIN	+ or -	Adjust the Minimum Output Voltage Default value is 0	
VMAX	+ or -	Adjust the Maximum Output Voltage	
IMAX	+ or -	Adjust the Maximum Output Current	
Remote V sens	SET	Toggle On/Off the Remote Voltage Sensing	Off

Level 2 (strict level), *continued*

Use → or ← keys to scroll the **Level 2** sub-menus. SET to enter menu. EXIT to return to previous menu.

DISPLAY	PRESS	ACTION	DEFAULT VALUE
Load sharing	SET	Toggle On/Off the Load Sharing	Off Negative slope regulation
Tcomp	SET	Toggle On/Off Temperature Compensation	Off
LCD pwr save	SET	Toggle On/Off LCD power save After 5 min of inaction on LCD goes on power save	Off
Remote Eq	SET	Toggle On/Off Remote Equalization	Off
AH display	SET	Toggle On/Off Ampere/Hour display	Off
Bat cap	+ or -	Adjust the Ampere/Hour capacity of Battery	

Readings

Use → or ← keys to scroll the **Readings** sub-menus. SET to enter menu. EXIT to return to previous menu.

DISPLAY	PRESS	ACTION	DEFAULT VALUE
Frequency		Actual frequency	Active
AC display	L	Display AC voltage	Off
	N	Display AC current	Off
AH meter		Display Ampere/ Hour in percent	Off
		Display Ampere/ hour	Off

NOTE:

If **FIXED CHARGER** mode is in the “OFF” position, then no alarms, float, equalize modes are accessible. (i.e. software exits set up mode after having chosen variable current or/and voltage)

Modbus (optional)

Material configuration

The RS-232 communication operates in a slave modbus, with 8 bits, 1 start and 1 stop bit. The speed of the transmission is configured on the communication card (PCOM1). The available speeds are 300, 1200, 4800, 9600 (default) and 19200 bauds. The address of the PCOM1 card is on board configurable from address 1 to 255. The default address is "1" .

RAM memory map

The following map show the structure RAM of the PCOM1 card. **(R)** means « **readable** » and **(W)** means « **writable** ».

VARIABLE	ADDRESS (DEC)	BYTES	STATUS
Vout	00	2	R
Vfloat / Vref (setting value)	01	2	W/R
Vequalize (setting value)	02	2	W/R
Volt low equalize (setting value)	03	2	R
Volt low alarm (setting value) (setting value)	04	2	R
Volt low alarm disconnect (setting value)	05	2	R
Volt high alarm (setting value)	06	2	R
Volt high alarm shut down (setting value)	07	2	R
GND+ (setting value)	08	2	R
GND- (setting value)	09	2	R
I out (setting value) (setting value)	10	2	R
I Lim (setting value) (setting value)	11	2	W/R
V ph1 (setting value) (setting value)	12	2	R
V ph2 (setting value) (setting value)	13	2	R
V ph3 (setting value)	14	2	R
I ph1 (setting value)	15	2	R
I ph2 (setting value)	16	2	R
I ph3 (setting value)	17	2	R
Alarm Rectifier Fail (status)	18H	1	R
Alarm High Volt (status)	18L	1	R

Table 1

RAM memory map, *continued*

VARIABLE	ADDRESS (DEC)	BYTES	STATUS
Alarm low Volt (status)	19H	1	R
Alarm neg ground (status)	19L	1	R
Alarm pos ground (status)	20H	1	R
Alarm AC Fail (status)	20L	1	R
Alarm HV ShutDown (status)	21H	1	R
Alarm Low Volt desc (status)	21L	1	R
Alarm AC high volt (status)	22H	1	R
Alarm AC low volt (status)	22L	1	R
Alarm High external temperature (status)	23H	1	R
Alarm low external temperature (status)	23L	1	R
Alarm High temperature of card (status)	24H	1	R
Alarm Battery Discharging (status)	25L	1	R
Alarm I Lim (status)	26H	1	R
Alarm Equalize (status)	26L	1	R
Alarm cut fuse (status)	27H	1	R
Not Used	27L	X	X
Equalize/Float	28	2	W/R
Reset Alarms	29	2	W
Password	30	2	W

Table 1, *continued*

NOTE:

Reading the value “FF_(HEX)” at any “Status Alarm” address means that this alarm has not been ordered with your charger.

1.1 Format for voltage and current values

Voltage and current values are coded on 2 bytes :

Example:

Vout = 651.3V (6513 decimal = 1971 hex),
so the coded value will be :

19 hex / 71 hex; (19 MSB, 71 LSB) or 6513 in decimal (65 MSB, 13 LSB)
(MSB : most significant byte, LSB : less significant byte)

1.2 Logic of Alarms:

Address value	FF	0	1
alarm state	Not available	Not active	Active

Table 2

1.3 Float/Equalize

The command “equalize/float” is coded on 2 bytes. The **least significant byte** (LSB) indicates the state of operation of the charger. (Reading mode) « 0 » indicates that the charger is in float mode, « 1 » indicates that the charger is in equalize mode (see Table 3).

The **most significant byte** (MSB) allows changing of the state of the charger (writing mode) when it's possible, meaning « correct pass word » and mode « remote RS232 = 1 » (see Table 4).

The equalize mode is authorized (i.e. remote RS232 = 1). To change the operation mode (Float or equalize) of the charger, refer to Table 3. If the value “0” is sent to address 28, the charger is forced to “float” mode. If the value sent to address 28 is “1”, the charger is forced to “equalize” mode.

Writing :

MODE \ ADDRESS	28
float	0000
equalize	0001

Table 3

Reading :

MODE \ ADDRESS	28
float	0000
equalize	0001

Table 4

1.4 Reset Alarm

To deactivate an alarm, just send the value « 1 » at the address 29 **(in writing mode)**.

Mode	Address
Alarm Reset	29 0001

Table 5

Troubleshooting

Field programming

Should trouble occur with your P4500 rectifier please read the following:



WARNING!

Only qualified personnel should service this unit. The battery and AC supply should be disconnected before replacing any component.

FAULT	RECOMMENDATION
No output	Verify that the AC breaker is closed (“ON”) Verify that the AC supply is of correct voltage and frequency Verify the DC output fuse Verify the output and input connections Replace control board PC20 Replace thyristor modules
Abnormal noise	Verify thyristors Replace control board PC20

If trouble persists please call:

1-800-863-3364

7 AM to 5 PM, Pacific Time and 24/7 emergency support

Regular preventive maintenance

Regular maintenance is required to ensure reliable operation of your system.

COMPONENT	ACTION	FREQUENCY
Battery	Measure and record the voltage across each battery cell and across the entire battery.	Monthly
Battery	Verify and record the electrolyte level of each battery cell. If necessary top off with distilled water	Monthly
Battery	Verify and record the specific gravity of each battery cell	Monthly
Charger	Verify the operation of all indicators	Monthly
Battery, Charger	Use a vacuum cleaner equipped with a small brush and remove any accumulated dust (especially around ventilation openings)	Yearly
Battery, Charger	Visually verify the condition of all components	Yearly
Battery, Charger	Verify all connections. If necessary, retorque to manufacturers specifications.	Yearly
Battery	Clean and re-grease all battery connections	Yearly
Battery	Wash battery using distilled water only.	Yearly

For systems supplied with lead acid batteries, a partial discharge of the battery is recommended on an annual basis, to verify battery and charger performance.

For systems supplied with nickel-cadmium batteries we recommend a complete discharge and decommissioning charge on a bi-annual basis. Alpha Technologies provides both these services.

Control board (PC) - Adjustment Procedure

Required tools:

DC voltmeter, DC ammeter or clamp-meter, DC load bank or dummy load (to simulate a load).

Use the test report of the unit (included in the user's manual) and refer to the following data:

DC output float voltage V_f
 DC output equalize voltage (if required) V_e
 DC output maximum current I_m

Example — 18Ni-Cd cell system (for your specific Ni-Cd or lead acid please use the information provided by the battery supplier)

Constant voltage:

- Float voltage = 1.42 volt/cell
- Equalize voltage = 1.55 volt/cell
- Number of cells = 18

Current limit:

Adjust the current limit to the test report value.

Nickel cadmium battery

A	B	C
Float voltage V_f	Number of cells x 1,42*v/cell	25,6 v
Equalize voltage V_e	Number of cells x 1,55**v/cell	27.9v
Auto equalize level V_{ae}	$V_f \times 0,85$	21.76 v
Maximum charging current I_{max}	I_{max}	5 Amp.

Control board (PC) - Adjustment Procedure, *continued*

Adjustment Procedure:

1. Switch the AC breaker off.
2. Switch the DC breaker off (if provided).
3. Disconnect batteries from charger.
4. Connect resistive load
5. Connect DC voltmeter across DC output terminal (see wiring diagram)
6. Switch the AC breaker on.

Use → or ← keys to scroll the Control sub-menus. **SET** to enter menu. **EXIT** to return to previous menu.

DISPLAY	PRESS	ACTION	VALUE
Float	+ or -	Adjust Float Voltage (V)	25.6 V
I LIM	+ or -	Adjust Current Limit (A)	5,0 A
Eq	SET + or -	Toggle On/Off Equalization Voltage Adjust Equalization Voltage (V)	On 27,9 V
T eq	+ or -	Adjust Equalization Time (Hour)	
L VEQ	+ or -	Adjust Low Equalization Voltage (V)	21,76 V
TI LIM E	+ or -	Adjust Time/Current limit Equalization (Minute)	5 min
AC Eq	SET	Toggle On/Off AC Equalization	On
Tfloat	+ or -	Adjust Float Timing (Days)	28 Days

Alarms Adjustment Procedure

Required tools:

DC voltmeter, DC ammeter or clamp-meter, DC load bank or dummy load (to simulate a load).

Use the test report of the unit (included in the user’s manual) to have the following data handy :

- DC output float voltage V_f
- DC output equalize voltage (if required) V_e
- DC output maximum current I_m

Example— 18Ni-Cd cell system (for your specific Ni-Cd or lead acid please use the information provided by the battery supplier)

Constant voltage:

- Float voltage =1.42 Volt/cell
- Equalize voltage =1.55 volt/cell
- Number of cells = 18

Nickel cadmium battery

A	B	C
Float voltage V_f	Number of cells x 1,42* v/cell	25.6 v
Equalize voltage V_e	Number of cells x 1,55** v/cell	27.9v
High volts alarm V_h	$V_e \times 1,03$	28.7 v
Low volts alarm V_L	$V_f \times 0,8$	20.4 v



NOTE:

Float and equalize voltage provided by the battery manufacturer.

Alarms Adjustment Procedure:

1. Switch the AC breaker off.
2. Switch the DC breaker off (if provided).
3. Disconnect batteries from charger.
4. Connect resistive load.
5. Connect DC voltmeter across DC output terminal (see wiring diagram).
6. Switch the AC breaker on.

Alarms Adjustment Procedure, *continued*

Use → or ← keys to scroll the Level 2 sub-menus. SET to enter menu. EXIT to return to previous menu.

DISPLAY	PRESS	ACTION	DEFAULT VALUE
Talarm	+ or –	Adjust alarm Timing (sec)	10 sec
HVAL relay xxx	+ or – NEXT NEXT, On/Off NEXT, + or –	Adjust High Voltage alarm level (V) Go to Relays selection/toggle menu Toggle On/Off High Voltage alarm Select relays number (1 to 7)	28,7 V On No. 2
LVAL relay xxx	+ or – NEXT NEXT, On/Off NEXT, + or –	Adjust Low Voltage alarm level (V) Go to Relays selection/toggle menu Toggle On/Off Low Voltage alarm Select relays number (1 to 7)	20,4 V On No.3
GNDF– relay xxx	+ or – NEXT NEXT, On/Off NEXT, + or –	Adjust Negative Ground Fault level (mA) Go to Relays selection/toggle menu Toggle Negative Ground Fault Select relays number (1 to 7)	5 mA On No. 4
GNDF+ relay xxx	+ or – NEXT NEXT, On/Off NEXT, + or –	Adjust Positive Ground Fault level (mA) Go to Relays selection/toggle menu Toggle Positive Ground Fault Select relays number (1 to 7)	5 mA On No. 4
AC Fail	+ or – NEXT NEXT, On/Off NEXT, + or –	Select relays number (1 to 7) Go to Relays selection/toggle menu Toggle On/Off AC Failure Alarm Select relays number (1 to 7)	 On No.5
Rectifier Fail	+ or – NEXT NEXT, On/Off NEXT, + or –	Select relays number (1 to 7) Go to Relays selection/toggle menu Toggle On/Off AC Failure Alarm Select relays number (1 to 7)	 On No.1

Power

Alpha Technologies 

Alpha Technologies
3767 Alpha Way
Bellingham, WA 98226
USA
Tel: +1 360 647 2360
Fax: +1360 671 4936
Web: www.alpha.com

Alpha Technologies Ltd.
4084 McConnell Court
Burnaby, BC, V5A 3N7
CANADA
Tel: +1 604 430 1476
Fax: +1 604 430 8908

Alpha Technologies
Europe Ltd.
Twyford House
Thorley
Bishop's Stortford
Hertfordshire
CM22 7PA
UNITED KINGDOM
Tel: +44 0 1279 501110
Fax: +44 0 1279 659870

Alpha Technologies GmbH
Hansastraße 8
D-91126 Schwabach
GERMANY
Tel: +49 9122 79889 0
Fax: +49 9122 79889 21

Alphatec, Ltd
P.O. Box 56468
Limassol, Cyprus
CYPRUS
Tel: +357 25 375675
Fax: +357 25 359595

AlphaTEK ooo
Khokhlovskiy Pereulok 16
Stroenie 1
109028 Moscow
RUSSIA
Tel: +7 495 916 1854
Fax: +7 495 916 1349

Alphatec Baltics
S. Konarskio G. 49
Vilnius 2009
LITHUANIA
Tel: +350 5 210 5291
Fax: +350 5 210 5292

Alpha Technologies
5 Avenue Victor Hugo
F-92140 Calmart France
FRANCE
Tel: +33 3 41 90 07 07
Fax: +33 1 41 90 93 12