

# ***RPM***

Remote Parallel Monitor

---

---

**Instruction Manual**

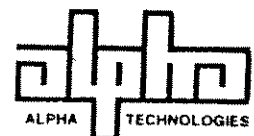



FILE

TABLE OF CONTENTS

AN OVERVIEW

INTRODUCTION  
SYSTEM CONCEPT  
ALPHA REMOTE STATUS MONITORING  
HOW TO USE THIS MANUAL

SECTION 1 - THE RPM CARD AND POWER SUPPLY

1.1 FEATURES  
1.2 SPECIFICATIONS  
1.3 PRECAUTIONS  
1.4 INSTALLING THE RPM  
1.5 START-UP PROCEDURE  
1.6 SIGNALS FROM RPM BOARD  
1.7 COMMANDS TO RPM BOARD  
1.8 INVERTER (STANDBY) MODE  
1.9 EXIT FROM INVERTER MODE  
1.10 CALIBRATION PROCEDURE

SECTION 2 - HOOKING UP THE RF COMMUNICATIONS MODEM

2.1 TEXSCAN VITAL SIGNS SYSTEM  
2.2 CENTURY III STATUS MONITOR  
2.3 JERROLD STSM STATUS MONITOR

SECTION 3 - USING THE SOFTWARE

3.1 TROUBLESHOOTING WITH THE STATUS MONITOR

APPENDICES

A INPUT/OUTPUT OPTIONS OF THE VARIOUS STATUS MONITOR  
SYSTEMS  
B LIST OF AVAILABLE EQUIPMENT

DRAWINGS

A		136-11	1077	Battery Connection Diagram
A	020-019-C0	266-1	2027	SPI/Output Filter Installation
A		262-1	2030	SPI/Output Filter Assembly
C		315-1	3027	Component Layout of RPM Control Board
A	740-120-C0		5005	Tamper Switch Installation
A			5007	Interconnect Cable, TDM-1 to RFC
A			5009	Interface Cable Assembly, Alpha to Century III Status Monitor
A			5016	Enclosure Cable Assembly, Alpha to Century III Status Monitor
A			5021	TDM-1 Installation Diagram
C			5022	Typical Set-Up of RPM
A			5023	Typical Installation Block Diagram
A			5031	Alternate Installation Block Diagram
B			5040	RPM Test Set-Up
A		496-10	5049	Wire Harness, TDM-1 to RPM.
A	870-100-C0	316-1	5050	Current Sense Cable
A			5056	Typical Status Monitoring Configuration, Alpha/Century III (External Transponder)
A			5057	Typical Status Monitoring Configuration, Alpha/Century III (Internal Transponder)
A		496-9		External Interface Connections

\* Wherever used in this manual, Texscan Vital Signs, Century III, Jerrold, and C-COR are registered trademarks of Texscan Corporation, Century III Electronics Inc., General Instrument Corporation and C-COR Electronics Inc., respectively.

## AN OVERVIEW

### INTRODUCTION

Over the past few years, Cable TV systems and services have become increasingly sophisticated, putting the pressure on the manufacturers of cable equipment to come up with quicker and easier methods of servicing such systems while keeping the maintenance costs down.

One such method involves the electronic surveillance of an entire CATV system or critical parts thereof. The hardware portion of this system is usually referred to as a Remote Status Monitor.

### SYSTEM CONCEPT

The Remote Status Monitor will comprise of the following basic building blocks:

- System Computer
- Headend or Plant Interface Module
- Two way Cable System
- RF Transponder Module
- Logic Interface to Power supply
- CATV Standby Power Supply

Refer to Alpha Drawing C5022 in the last part of this manual.

Operating under special software commands, the computer will send out a digital code to the Plant Interface Module, which in turn converts this code into a modulated RF signal to be transmitted throughout the Cable System. This modulated RF contains a serial data stream that locates a specific power supply as per the computer instructions. Once the transmitted code matches the internal code of the "addressed" power supply, two-way communications can be established with this unit. The power supply can now be commanded to perform a specific set of functions, as incorporated in the computer "software". It will report back on a different RF frequency its status and other pertinent information such as battery voltage, outside temperature, and so forth.

The logic interface card to the power supply will keep track of all functions of the power supply. Each power supply in the system can be monitored, or "interrogated" on an individual basis. For example, we can send out a command to place the unit in the high charge mode or to do a self-test. We can also retrieve information regarding the condition of the batteries as well as the length of time the power supply has been on standby.

This information allows us to judge the condition of each power supply and its ability to provide satisfactory standby performance. More importantly, it allows us to do preventative maintenance on an "as required" basis with obvious advantages over a scheduled maintenance program.

The ability to remotely analyze the nature of a power supply malfunction further allows us to dispatch service personnel equipped

with the right parts or tools to fix the problem. The savings in labor costs are clear. In addition, one can dispatch moderately skilled persons to the site as the problems and remedy can be closely defined from the headend or office location.

#### ALPHA REMOTE STATUS MONITORING

The Alpha Remote Status Monitor System offers the following features:

1. Compatibility with almost any status monitor system presently manufactured. The monitoring features are limited by the number of input/output pins made available at the status monitor transponder, and by the level of software written for the system (this depends on the manufacturer).
2. Easy to retrofit on an existing cable system utilizing Alpha power supplies. In most instances no modifications need to be performed on the power supply and enclosure. A simple exchange of logic cards and installation of the interface cables is all that is necessary.
3. Easy to connect the RF portion when used with certain transponders. The Alpha logic card provides auxiliary power to the transponder thus eliminating the need for a separate power supply for the transponder. RF cabling to the enclosure is minimized because the same cable which carries power from the supply to the cable system can be used for two-way RF communications.
4. Can co-exist with an existing or proposed amplifier status monitoring system. Again, depending upon the choice of status monitor hardware, amplifier and power supply status monitoring can share the same headend plant interface and use similar or identical transponders at each remote location. The cost savings are obvious.

#### HOW TO USE THIS MANUAL

The manual is divided into four sections:

1. The installation and operating instructions for the RPM card, to give an understanding of what it is capable of doing and to prepare it for interacting with other parts of a status monitor system.
2. The installation of the RF communications modem, consisting of a Processor to Plant Interface at the headend and many Transponder Modules, one for each power supply, with the appropriate connections to the power supply and to the cable system. The transponders may be located either inside the power supply enclosure, or outside in a separate housing with an umbilical cable to the power supply.
3. General tips on the use of the software for monitoring power supplies and the interpretation of faults for troubleshooting purposes.

4. Appendices for specific technical details on equipment which may be used in a system.

Drawings are located at the end of this book and are inserted in numerical order for ease in finding those referenced by the text.

If additional help is needed to complete your particular installation or if you have custom requirements, please feel free to contact Alpha Engineering, either directly or through your nearest Alpha representative.

In the U.S., contact Alpha Technologies Inc. (206) 671-7703  
In Canada, contact Alpha Technologies Ltd. (604) 430-1476

## SECTION 1 - THE RPM CARD AND POWER SUPPLY

### 1.1 FEATURES

1.1.1 The RPM Remote Parallel Monitor Card is a logic controller board which may be used to upgrade the Alpha AP Series of Standby Power Supplies - any one of the AP660, AP960, AP880, AP660HE or AP960HE models - for the purpose of remote status monitoring. It directly replaces any of the older existing logic cards without modification or recalibration of the power supply in which it is installed.

1.1.2 The RPM card is available in versions directly compatible with the following status monitor systems of other manufacturers:

1. Texscan Vital Signs\* (requires no modification - all interface cables may be obtained from Alpha as accessories)
2. Century III\* Model 8927 (requires special interface cable and enclosure connector which must be factory installed, and RPM card with Century III option)
3. Jerrold\* Model STSM (requires special interface cables and CATV enclosure fittings as well as RPM card with Jerrold STSM option)
4. C-COR\* (in process of finalizing interface levels at time of writing this manual - consult Alpha Engineering)

\* Texscan Vital Signs, Century III, Jerrold, and C-COR are registered trademarks of Texscan Corporation, Century III Electronics Inc., General Instrument Corporation and C-COR Electronics Inc.

The type of measurements possible and the degree of control over the power supply both depend on the choice of status monitor system and software. More details are given in Section 3 of this book.

Status monitor systems other than those mentioned above may be adapted to the RPM board. For custom requirements, contact your nearest Alpha representative or Alpha Engineering directly.

1.1.3 The RPM card may be used as a stand-alone unit, in the absence of status monitoring, to provide some local monitoring features within the power supply that it is residing. Used in this way, it performs identically to the Model APM670 logic card, providing such useful functions as:

1. Temperature compensated charging over a wide range (0°C to 60°C)
2. Dual charging modes (float and equalize) sequenced automatically by a crystal controlled clock.
3. Current limited charger to prevent damage to electronics

when battery faults occur

4. Low voltage dropout protection to prevent batteries from becoming totally discharged and damaged
5. Inverter short circuit protection to protect against all fault conditions in the main transformer

A single chip microcomputer continuously monitors the status of the power supply, such as battery failure, output failure, whether or not in standby, and sends these output (alarm) flags via an input/output port for connection to a status monitor transponder. In addition, the microcomputer performs on-board functions (independently of the status monitor control) such as determining when and how fast to charge the batteries (float or equalize) and whether or not to flash a local alarm light on the power supply. It is also possible to make simple changes to the RPM board's software to maintain compatibility with various status monitor systems which have limited monitoring capability.

## 1.2 SPECIFICATIONS

Input Power Requirements	20-48 VDC at 150 mA max.
Output Power for Aux. Circuitry	14 VDC @ 500 mA, regulated
Parallel Port	Pin 1 - Battery Neg., Logic Common 2 - External Power (+14 VDC @ 500 mA) 3 - Standby Alarm 4 - Output (60 VAC) Voltage 5 - Battery Voltage 6 - General Alarm 7 - Tamper Alarm 8 - Output (60 VAC) Current 9 - Set Equalize 10 - Output AC Alarm 11 - Set Self Test (Standby) 12 - Battery Neg., Logic Common 13 - Not Used 14 - Tamper Switch 15 - Tamper Switch
Commands (TTL, CMOS compatible)	- Set Self Test - Set Equalize - Reset Alarms
Alarm Outputs (TTL, CMOS)	- General Alarm for Batt/Inv Fail (latched) - Standby Alarm for Inverter Mode Operation (latched) - Output AC Alarm for Output AC Fail (latched) - Tamper Alarm



1.4.2 If the RPM card replaces an older existing logic card, proceed as follows:

1. Disconnect the batteries by unscrewing the battery fuse (Model AP660) or by pulling the breaker (Models AP960, AP880, AP660HE, and AP960HE). Use this method only if the battery wiring has already been connected to the power supply and is not disturbed - otherwise proceed as in Section 2.2 on Battery Connections. Disconnect the AC utility power by pulling the line power cord or switching off the utility breaker.
2. Wait 2 minutes for the power supply capacitors to discharge sufficiently, then remove the old logic card by pulling it straight out of its edge connector.
3. Unpack the RPM card, being extremely careful to handle it only by the edges. Keep fingers away from the static-sensitive ICs, or use a grounded wrist strap if they must be touched.
4. Plug the RPM card into the empty edge connector, being careful to insert it straight and to seat it squarely into the connector.

CAUTION: USE CARE WHEN HANDLING A POWER SUPPLY WHICH HAS JUST BEEN TAKEN OUT OF SERVICE FOR INSTALLING THE RPM BOARD. THE POWER TRANSFORMERS CAN GET VERY HOT IN ACTUAL OPERATION AND MAY CAUSE THE INSTALLER TO DROP THE SUPPLY. THE USE OF GLOVES IS HIGHLY RECOMMENDED.

1.4.3 If a status monitor system is to be connected up to monitor the power supply, refer to Section 2. If no status monitoring is used, go to Section 1.5 on Start-up Procedure.

## 1.5 START-UP PROCEDURE

1.5.1 This procedure may be followed with or without hooking up to a remote status monitoring system. If status monitoring is required, make sure all connectors are fitted before the power supply is energized, by following the steps in Section 2.

1.5.2 With the batteries disconnected, or the battery fuse/breaker pulled out, plug the AC line cord into a utility outlet. In approximately 30 seconds, the red standby light on the front panel of the power supply should flash at an approximate 1 Hz rate. Reset the flashing alarm by depressing the pushbutton on the RPM card or the front panel (if provided, this is marked TEST/EQ RESET). Reconnect battery wiring or reactivate fuse/breaker.

1.5.3 Depress the pushbutton twice to place the power supply in the inverter mode. Depress once more to de-activate the inverter and switch the unit back to AC line operation. The charger will be in high charge (EQUALIZE) mode when this is done. Successive pushes on

the switch will repeat this cycle.

## 1.6 OUTPUTS FROM RPM BOARD

Refer to Alpha Drawings D2039 (schematic) and C3027 (component layout).

The RPM card has seven output pins which change logic state or vary in analog voltage level to correspond to various faults and loading conditions within the power supply. As well there are two auxiliary supply pins to power external equipment such as a status monitor transponder. These pins are part of the input/output port or connector which is designated as J1. The number of outputs which can be accessed for status monitoring will depend on your choice of status monitoring system.

### 1.6.1 ALARM CONDITIONS

There are four alarm conditions which can occur if there are faults or potential faults in the power supply: one flashing (hardware) alarm called the STANDBY light mounted on the enclosure or power supply front panel, and three logic (software) alarms available for connection to a status monitor system. The three logic alarms are GEN PS, STANDBY, and 60 VAC.

### 1.6.2 FLASHING ALARM

This operates independently of any status monitor and is mainly used to alert field service personnel of any of the following conditions:

1. Initial powering up of the supply from a completely de-energized condition.
2. Battery condition deteriorating so that the total voltage drops rapidly below 31.2 volts when in the SELF-TEST mode. This is followed by an immediate transfer back to AC utility power.
3. Inverter failure during inverter mode of operation. See Section 1.9.2.
3. Battery failure during inverter mode of operation and subsequent return to AC utility power.
4. 60 VAC output shorted momentarily or fuse blown during inverter mode, with subsequent return to AC utility power.

The FLASHING alarm is not accessible on the RPM board for status monitor connection, but normally open and normally closed contacts are available on the power supply main terminal strip TB1, if a hookup is required. See the Alpha manual entitled "Operating Instructions for AP Series Standby Power Supplies" for further details.

### 1.6.3 GEN PS ALARM

The General Power Supply Alarm is activated by the same conditions as in Section 1.6.2. Its main use is for status monitoring, and connection is via pin 6 of connector J1. The alarm output is normally high (typically 14 volts) until a fault occurs, at which point it becomes latched active low (typically less than 1 volt). It must then be manually reset to a high state using the TEST/EQ RESET pushbutton or by the remote status monitor. See Section 1.7.3 for further details.

NOTE: WHEN THE GEN PS ALARM IS MONITORED AS A SEPARATE ALARM (DIGITAL LEVEL ONLY) RESISTOR R134 MUST BE REMOVED FROM THE RPM BOARD. SEE ALPHA DRAWING C3027. IF THE RESISTOR IS LEFT ON, THEN THE STANDBY ALARM PIN (SECTION 5.4 BELOW) IS NOT USED FOR MONITORING. THE GEN PS ALARM PIN INDICATES TWO LEVELS: HIGH (14V USUALLY) FOR NEITHER ALARM, HALF SCALE (7V) FOR STANDBY ONLY AND LOW FOR EITHER/BOTH GEN PS AND STANDBY.

### 1.6.4 STANDBY ALARM

This alarm is active low whenever the inverter is running. To use for status monitoring, connect to pin 3 of connector J1. Resetting is done automatically when the power supply transfers to AC utility power.

### 1.6.5 60 VAC ALARM

This is activated if the 60 VAC output fuse is blown, or if an overload on this output causes the voltage to drop below a specific level. The overload may be momentary or prolonged. The output goes active low when the fault occurs, and is latched. Connection for status monitoring is made via pin 10 of connector J1. Resetting must be done manually by first correcting the fault condition (replacing the blown fuse, for example) and then pushing the TEST/EQ RESET switch or issuing a command from the remote status monitor terminal.

### 1.6.6 TAMPER ALARM

This is a logic level which is controlled by an external switch on the power supply. The switch supplied with the RPM accessory kit is a normally-closed contact which is kept open by shutting the enclosure door to the power supply. By opening the door the switch again closes, providing an active low level to the status monitor. The switch is connected to pins 14 and 15 of J1. Connection to the status monitor is via pin 7 of J1. The status monitor system used should have an input capable of 15 VDC and the necessary software for latching this level.

### 1.6.7 BATTERY VOLTAGE

This is a scaled-down analog level available for A/D measurements possible with some status monitor systems. The output is 0-24 volts to represent a battery range of 0-48 volts. Connection is made at pin 5 of connector J1. The particular status monitor system used

must be capable of handling a 24 VDC input and the software should have provisions for scaling up to the actual battery level.

#### 1.6.8 60 VAC VOLTAGE

This is a scaled-down analog level of the output voltage. Connection is made at pin 4 of J1. The particular status monitor system used must be capable of processing AC levels up to 100 volts peak and the software should have scaling provisions.

#### 1.6.9 60 VAC CURRENT

This is a scaled-down level of the output current. The scaling factor of 0.4 volts per ampere of load current gives a maximum 6 volts for a 15 amp supply. The current is sensed from the output ammeter M1 on the power supply, by means of a twisted wire pair which plugs into connector J3 on the RPM card (this sense cable is part of the RPM accessory kit). Connection for status monitoring is made at pin 8 of J1. The status monitor system used must be capable of a 15 VDC input and also have scaling provisions.

#### 1.6.10 AUXILIARY POWER

Power for the status monitor transponder may be derived from the +14 VDC supply on the RPM card, available at pin 2 of J1. Pin 1 or 12 may be used as the common return. The maximum supply current available at this pin is 50 mA.

CAUTION: THE COMMON PIN (1 OR 12) IS TIED TO THE 60 VAC COMMON AND ALSO THE BATTERY MINUS TERMINAL, AND HENCE TO CHASSIS (ENCLOSURE GROUND). THE LOGIC GROUND ON THE RPM CARD IS A COMPLETELY SEPARATE GROUND FROM CHASSIS GROUND AND SHOULD NEVER BE CONNECTED TO AN INSTRUMENT WITH AN AC EARTH GROUND SUCH AS AN OSCILLOSCOPE, FOR TROUBLESHOOTING PURPOSES. ONLY AUTHORIZED SERVICE PERSONNEL SHOULD ATTEMPT CALIBRATION OR REPAIR WORK ON THIS BOARD. UNAUTHORIZED WORK PERFORMED ON THIS BOARD WILL VOID THE WARRANTY.

#### 1.6.11 DISPLAYING ALARMS

For specific instructions on how to display the above alarm conditions and to enter upper and lower limits for flagging faults, you should refer to the appropriate instruction manual for your particular make of status monitor system.

### 1.7 COMMANDS TO RPM BOARD

#### 1.7.1 SET EQUALIZE MODE

Under normal AC utility power operation, the batteries are placed on FLOAT charge, which is normally a trickle charge, unless the batteries are severely discharged. An EQUALIZE or high charge rate is activated for a 3 hour period once every 14 days to even out the charge in the battery string. This occurs automatically whether or not a status monitor system is connected. If an override from FLOAT

to EQUALIZE is desired at any time during a FLOAT period, then the status monitor must be commanded to effect a switch closure on the EQUALIZE input (pin 9 of connector J1) to force it low. Upon release of the EQUALIZE input, it will float high and the charger will revert to FLOAT operation.

NOTE: DO NOT KEEP THE EQUALIZE INPUT LOW INDEFINITELY OR THE BATTERIES MAY BE OVERCHARGED. A TIMEOUT ON THE RPM CARD WILL BRING THE CHARGER OUT OF EQUALIZE AFTER AN EIGHT HOUR PERIOD FOR OCCASIONS WHEN THE EQUALIZE COMMAND IS ACCIDENTALLY LEFT ON, BUT IT IS WISE TO RESERVE THIS FOR BACKUP USE.

### 1.7.2 SET TEST MODE

Under normal operation of the RPM card, the power supply inverter circuit and battery condition are tested every 30 days (SELF-TEST or TEST mode). This is done by a timer which automatically forces the inverter to operate in the presence of AC utility power. If either the inverter or one of the batteries is faulty, the power supply transfers back to AC utility power and latches both a FLASHING alarm and the GEN PS alarm (see Sections 1.6.2 AND 1.6.3). If the TEST mode is required immediately without having to wait for the timer to sequence through (this method could take weeks), then use one of the following methods:

1. Depress the TEST/EQ RESET button on the front panel of the power supply. The red STANDBY light on the power supply should come on and remain lit as long as the inverter is operating.
2. Use a suitable command at the status monitor terminal to effect a contact closure on the TEST input (pin 11 of connector J1) of the RPM board.

NOTE: REMEMBER TO RELEASE THE COMMAND FOLLOWING THIS TEST SO THAT THE BATTERIES ARE NOT DEPLETED UNNECESSARILY. THE RPM BOARD WILL AUTOMATICALLY TIME OUT ONE HALF HOUR AFTER THIS TEST HAS STARTED, BUT IT IS ADVISED NOT TO RELY ON THIS CONSTANTLY, AS THE NORMAL TIMING ROUTINES FOR CHARGING MAY BE DISRUPTED.

### 1.7.3 RESET OF ALARMS

The alarm conditions in Sections 1.6.2, 1.6.3 and 1.6.5 may be reset by the following procedure:

1. Remove the condition which has caused the fault. See the Troubleshooting Chart in Section 3 for help in diagnosing faults using remote status monitoring. In some instances the fault must be corrected before any reset can be performed (as in the case of an output fuse blowing).
2. If the reset is performed at a field location, depress the TEST/EQ RESET pushbutton on the front panel of the power supply, or the pushbutton on the RPM card (the latter may

be inaccessible for certain installations).

3. If the reset is done from a head-end location as in a status monitor terminal, then the appropriate command must be given to either the TEST or EQUALIZE input on the RPM board. Use the TEST input if the status monitor system you are using has provisions for only one logic closure to control the power supply. Use the EQUALIZE input if two logic closures are available.

NOTE: WHEN ONLY ONE LOGIC CLOSURE IS AVAILABLE, AND THE TEST INPUT IS USED TO RESET THE POWER SUPPLY, AN ALARM CONDITION IS ASSUMED TO BE IN EFFECT. IF AN ALARM DOES NOT EXIST, THEN THE POWER SUPPLY WILL BE PLACED IN THE SELF-TEST MODE. TO MINIMIZE WEAR ON THE TRANSFER RELAY WITHIN THE POWER SUPPLY, USE THE TEST PIN TO RESET ONLY WHEN THERE IS AN ACTUAL ALARM.

## 1.8 INVERTER (STANDBY) MODE

1.8.1 The inverter is activated whenever an AC power outage occurs, but only if the batteries have been initially charged to exceed a given voltage (usually around 37 volts). Once the inverter is running, the batteries may continue to power the inverter until they reach 31.2 volts. Cutoff occurs at this level to prevent possible damage to the batteries through further discharging.

1.8.2 Other conditions which activate the inverter are:

1. AC utility power "brownout" where the input voltage to the supply drops below a set level (around 75 VAC) and regulation of the output voltage cannot be maintained.
2. Automatic SELF-TEST mode where the RPM board forces inverter operation for one-half hour, the test being done every 30 days.
3. Manual interaction by field service personnel, by depressing the TEST/EQ RESET switch on the front panel of the supply.
4. Remote command via the status monitor terminal by forcing the TEST input of the RPM board low. See Section 1.7.3 for details.

## 1.9 EXIT FROM INVERTER MODE

1.9.1 After restoration of AC utility power (following an outage) the inverter is automatically turned off, and the power supply continues to provide 60 VAC power from the utility power line. There is an approximate delay of 30 seconds before transfer from inverter to line, to allow for settling of the input AC voltage.

1.9.2 After forcing inverter operation, using either automatic or

manual SELF-TEST functions as in Section 1.8.2, the inverter may be deactivated and AC utility operation restored, by one of the following means:

1. Depressing the TEST/EQ RESET switch once.
2. Remote command via status monitor by cancelling the TEST mode as in Section 1.7.3 or by resetting the alarms (though no alarm may be present) as in Section 1.7.1.
3. Automatic timeout of the RPM board after one-half hour.
4. Failure of inverter or batteries before the one-half hour timeout period. This gives rise to a FLASHING alarm as well as a GEN PS alarm.

## 1.10 CALIBRATION PROCEDURE

Refer to Alpha Drawings D2039 and C3027 to locate the various pins and adjustment pots. Tools required are:

- 1 Digital voltmeter
- 1 Small screwdriver or tweaking tool
- 1 Alpha extender card

### 1.10.1 LOW VOLTAGE (LV) CUTOUT

This adjustment sets the level at which the inverter is shut down during a prolonged standby period, in order to prevent damage to the batteries. The level is typically 31.2 volts but may vary slightly due to battery ripple voltage. Normally this level is preset at the factory and should not be disturbed during field operation. If recalibration must be performed, however, a battery simulator such as a high current power supply must be used. Start with the power supply in the inverter mode and a "battery" voltage of 39 volts. With the LV potentiometer (R111 in component layout drawing) in a fully counter-clockwise position and the "battery" voltage decreased to 30.5 volts (this will compensate for battery ripple under typical loading) turn slowly clockwise until the power supply inverter shuts down (red standby light or LED goes out).

NOTE: On newer RPM boards it is possible to set the charger voltage below 30 volts. By using this as the battery simulator, the LV setting can then be adjusted properly. To do so the batteries must be disconnected (CAUTION: REMOVE BATTERY WIRES AT BATTERY POST, NOT AT POWER SUPPLY, FOR SAFETY REASONS) and the power supply should be in the float mode (see Section 1.10.2 below). Monitor the voltage at pin 14 of IC chip U17. First set the LV pot R111 fully counter-clockwise and the float voltage to higher than 42 volts, to toggle pin 14 low (less than 2V). Then set the float voltage for 30.5 volts and adjust R111 slowly until pin 14 goes high.

### 1.10.2 FLOAT (FL) CHARGE LEVEL

To enter the float mode of charging, the power supply must first be reset. This is done by following the normal start-up procedure (see Section 1.5) and then resetting the flashing alarm light. With the batteries disconnected (CAUTION: remove battery wires at battery posts, not at power supply, for safety reasons) measure the voltage at pins 1 and 2 of terminal block TBI (this is the heavy terminal strip on the left hand side of the power supply on AM-660, AM-960, and AM-880I models, and on the rear panel on AP-660HE and AP960HE models). Adjust the FL potentiometer R110 on the RPM board to achieve the desired setting (clockwise to decrease float voltage). See Section 1.10.8 for recommended levels.

### 1.10.3 EQUALIZE (EQ) CHARGE LEVEL

The equalize mode of charging is activated by depressing the TEST/EQ RESET switch once more after the float mode has been selected, or after any return to normal (AC line) operation. The batteries must be disconnected in making any adjustments as in changing float settings. Adjust the EQ potentiometer R109 clockwise to increase the equalize charge voltage to the recommended level.

### 1.10.4 BATTERY VOLTAGE SCALING

The voltage present at the BATTERY + and COMMON (pins 5 and 1 of connector J1) is adjusted by A/D potentiometer R108 so that it is exactly one-half the measured battery voltage at the terminal block on the power supply (terminals 1 and 2 of TBI). Use a digital voltmeter set to read volts DC.

### 1.10.5 OUTPUT (60 VAC) VOLTAGE SCALING

The voltage present at the 60 VAC and COMMON (pins 4 and 1 of J1) is adjusted by the OV potentiometer R128 so that it is exactly one half the measured output voltage at the terminal block of the power supply (terminals 3 and 4). Use a digital voltmeter set to read volts AC.

NOTE: If the voltmeter you are using measures in AVERAGE volts, not TRUE RMS volts, then the unscaled reading at the terminal block may seem high. Ignore this and calibrate the OV setting using AVERAGE readings anyways. The scaling will be correctly presented to the status monitor and can then be scaled upwards using software.

### 1.10.6 OUTPUT (60 VAC) CURRENT SCALING

The voltage present at the OUTPUT CURRENT and COMMON (pins 8 and 1 of J1) is adjusted by the OC potentiometer R107 when a fixed load is connected to the output. A load current of 10 amps may be used to give a 4 volt output at the OUTPUT CURRENT pin. The output ammeter on the power supply may be used to give an actual current reading; use a digital voltmeter on DC volts to measure the 4 volts. Other load currents and the appropriate scaled down DC levels (use 0.4 volts DC per amp AC of load current) may also be used.

### 1.10.7 TEMPERATURE COMPENSATION

The charger on the RPM board is set to track the recommended battery charge curve for most rechargeable lead-acid batteries. The curve provides for a 90 mV increase in charger voltage (per set of three batteries) for every 1 degree Celsius drop in temperature below 25 °C (or 50 mV per degree Fahrenheit). There is a similar drop in charger voltage for increasing temperatures, with essentially no charging taking place at temperatures above 40 °C (104 °F). Calibration is not required as the compensation tracks the FLOAT and EQUALIZE settings approximately.

### 1.10.8 RECOMENDED CHARGER SETTINGS

Based on information compiled from various battery manufacturers, the following charger settings have been established for the RPM board:

Battery type	Lead-antimony	Lead-calcium	Gel-Cell
FLOAT	39.4 V	41.0 V	41.0 V
EQUALIZE	42.4 V	43.5 V	43.5 V

These levels should be adjusted with the RPM card at room temperature (20 °C) after a five-minute stabilization period for the temperature compensation circuit. In instances where the batteries are becoming overcharged and consuming excessive water, adjust the FLOAT settings down by approximately 0.4 volt.

## SECTION 2 - HOOKING UP THE RF COMMUNICATIONS MODEM

CAUTION: READ EACH SECTION CAREFULLY BEFORE INSTALLATION. PAY PARTICULAR ATTENTION TO THE WAY THAT CONNECTORS ARE PLUGGED INTO THEIR RESPECTIVE PORTS, OR DAMAGE TO THE RPM BOARD AND TRANSPONDER COULD RESULT.

### 2.1 TEXSCAN\* VITAL SIGNS SYSTEM

#### 2.1.1 PREPARING THE CABLE SYSTEM

Make sure that two-way communications has been established for the cable system before proceeding.

The preferred means of coupling the Alpha Power Supply into the trunk distribution system for status monitoring is by means of a power-passing type Directional Coupler such as a DC-12 or DC-16. There are no modifications necessary to the power supply's enclosure because it comes ready-equipped with the necessary fittings for injecting and receiving RF signals through the same cable which carries 60 VAC power. For a typical installation see Alpha Drawing A5023.

An alternate means of coupling, where power inserters are already in use next to the power supply, requires that line taps be installed or a tap brought from a nearby amplifier. Use a duplex filter so that the tap can pass RF signals both ways; the high frequency out (88.2 MHz standard) and the low frequency in (5.4 MHz standard). Be sure to remove the bridger fuse so that no AC power can flow out of the tap. See Alpha Drawing A5031.

#### 2.1.2 READYING THE ENCLOSURE

If line taps are used, install F-81 type connectors in an appropriate spot on the bottom of all enclosures which are to receive the status monitoring equipment. Use RG59/U coaxial cable to connect enclosure to tap.

If line taps are not used, the 60 VAC output power cable is used to carry RF also. Check to make sure the enclosure has the proper SPI Output Filter with the RFC provision for status monitoring. Older enclosures (pre October 1982) do not have this feature, but retrofit kits may be ordered from Alpha. See Alpha Drawings A2027 and A2030.

#### 2.1.3 INSTALLING THE HEADEND INTERFACE

The Model PPI-1 Processor to Plant Interface is a product of Texscan Corporation of Indianapolis, Indiana. Alpha Technologies has no affiliation with Texscan and has not entered an agreement with Texscan to represent their product. We will however, as a service to our customers, pass on problems or enquiries to the manufacturer and endeavour to provide new systems users with our field experience gained from existing installations.

The forward frequency (usually 88.2 MHz but may vary from system to system depending on allocation of existing cable signals) should enter the first amplifier in the cascade at -7 dB (or 17 dB below the video carrier). A convenient means to enter the system may be the test point located on the first amplifier, which is usually attenuated 20 dB. Adjust the MOD/TX RF level to achieve the -7 dB figure.

For more detailed information on setting the forward and reverse levels on the PPI-1, consult the Texscan PPI-1 User/Maintenance Manual.

#### 2.1.4 INSTALLING THE TRANSPONDER (TDM-1)

Refer to Alpha Drawing A5021 for details. Plug the 12-wire TDM-to-RPM harness (see also Drawing A5049 for fabrication details) into the TDM-1 first. The housing on the end of the harness is polarized; if it does not seat properly it may be reversed. Note carefully in Drawing A5021 how the pins in the rectangular port of the TDM-1 are numbered from 1 to 12. Pin 1 is closest to the RCA phono jack hole on the TDM-1. Select the proper end of the TDM-to-RPM harness so that the one black (or dissimilar) wire is plugged into pin 1. Plug the coaxial TDM-to RFC cable (see Drawing A5007 for fabrication details) into the phono jack opening of the TDM-1.

Attach the TDM-1 to the top surface of the utility breaker housing (see Drawing C5022) using double-sided adhesive foam tape. Connect the free end of the coaxial cable to the SPI Output Filter (if Directional Couplers and no line taps are used) or to the previously mentioned F-81 fitting (if Power Inserters and line taps are used).

NOTE: The 5.4 MHz return signal is normally at +40 dB so that the typical 22 to 32 dB return loss in a line tap is unimportant. Additional attenuation in the order of 10 to 30 dB should be added between the TDM-1 and SPI Output Filter (or F-81 fitting). The level at the input of the return amplifier should be measured and adjusted to the appropriate level by padding. The RF output level of the TDM-1 module is not normally adjusted. Remember that all pads affect both forward and return levels.

The dynamic range of the RF is 80 dB or +/-40 dB. This means that both the PPI-1 and TDM-1 are capable of outputting 40 dB or more unpadding, and receiving -40dB.

#### 2.1.5 CONNECTING TO RPM CARD

The pinout configuration of the RPM logic board is identical to that used on the Texscan TDM-1A Transponder Data Module (this is part of the Vital Signs System but is mounted inside the Alpha power supply enclosure). The interconnection cable between the RPM and the TDM-1A is by means of a 12-wire harness terminated on both ends with an in-line mass termination type housing of the Amp or Molex variety, with 0.1" spacing between adjacent pins (see Alpha Drawing A5049). Care must be taken to insert the polarized housings correctly into

their respective ports. If the housing does not go in all the way, it is probably inserted the wrong side up.

Connect the free end of the TDM-to RPM harness to the RPM card. The input/output port on the RPM is a 15-pin header strip with pin 1 nearest the metal heatsink. The black (or dissimilar) wire on the TDM-to-RPM harness which connects to pin 1 of the TDM-1 should go to pin 1 of the RPM also.

Install the Tamper Switch in the battery shelf of the enclosure, near the door hinge side, as per Alpha Drawing A5005. Do not forget to install the adhesive backed clip on the door to activate the switch afterwards. Plug the Tamper Switch into the remaining 2 pins (14 and 15) of the RPM card. Note that pin 13 is unused, and is either removed or bent to prevent accidental connection. Polarity is unimportant but the housing should seat fully on the board.

Plug the Current Sense Cable (see Alpha Drawing A5050) into the RPM card at the 2-pin header labelled J3. Polarity is unimportant but make sure that the wire housing is properly seated.

## 2.2 CENTURY III\* STATUS MONITOR

This system is the Model 8927 with Model 3181 Transponder Module. The transponder is located inside an amplifier housing rather than in the Alpha power supply enclosure. The amplifier should be fitted with a weatherproof, MS style, 6-pin connector with female pins (ordered from the amplifier manufacturer). The Alpha supply should be fitted with a weatherproof 9-pin female connector of the twist-lockable variety. An interface cable assembly connects the amplifier to the enclosure. This cable is either available from Alpha or may be made up by following Alpha Drawing A5009.

Inside the power supply enclosure (or the power supply module if a rack-mount head end unit is used) there should be a short wire harness with its free end terminated in an inline housing (see Alpha Drawing A5016). Plug this end into the RPM card.

For further information on installation of the Headend Interface and the Transponder Modules, consult the manufacturer.

## 2.3 JERROLD\* STSM STATUS MONITOR

2.3.1 This system uses the Jerrold Model CTSM Headend Control Transceiver and the Jerrold Model STSM Remote Status Monitoring Module. The preferred method of installation is to mount the STSM module on a messenger wire (external to the power supply enclosure). Smaller diameter drop cable is then used to connect the STSM to the power supply enclosure. See the Jerrold manual titled "Installation and Operating Instructions 435-922-01" for further information.

The EXTERNAL AC STANDBY port (J3) is used for monitoring the status of the power supply and the RETURN FEEDER SWITCH CONTROL (J2) is used

to remotely command the power supply.

To prepare the enclosure, install F-81 type fittings in an appropriate place on either the bottom or rear of the enclosure (depending on style). Use RG59/U cable to connect to J2 and J3 on the STSM.

A harness must be made up to connect the F-81 enclosure fittings to header strip J1 on the RPM. This harness may be ordered separately from Alpha or assembled as per Alpha Drawing A5051. J2 on the STSM connects to pin 11 (SELF-TEST) on the RPM, and J3 on the STSM connects to pin 3 (STANDBY FLAG) on the RPM. See Sections 1.7.2, 1.7.3, and 1.6.4 in this manual for an explanation of the RPM pinout functions.

For information on how to install the Headend Control Transceiver and to adjust RF levels, consult the manufacturer's instruction manual.

#### 2.4 C-COR\* STATUS MONITOR

We are in the process of finalizing interface levels at the time of writing. For further information consult Alpha Engineering.

## SECTION 3 - USING THE SOFTWARE

### 3.1 TROUBLESHOOTING WITH THE STATUS MONITOR

The number and type of signals sent from the RPM card will of course depend on the features of the status monitor system being used. For measuring such parameters as battery voltage and 60 VAC output voltage the status monitor transponders connected to the power supply must be capable of analog to digital (A/D) measurements for both AC and DC signals. For other status conditions such as operating status (standby or utility mode) a simple detection of logic level is all that is needed. Refer to the appropriate instruction manual for your type of status monitor.

#### 3.1.1 POSSIBLE ALARM CONDITIONS

There are eight possible combinations of alarms that may occur when the RPM board is interfaced to a status monitor system. They are only available at the status monitor terminal if the hardware and software for the particular status monitor system used are able to accommodate and display these conditions. These modes and the appropriate section to refer for troubleshooting are given in the table below.

ALARM CONDITION (L = ON, H = OFF)			REFER TO
GEN PS	STANDBY	60 VAC OUTPUT	SECTION:
L	L	L	3.1.2
L	L	H	3.1.3
L	H	L	3.1.4
L	H	H	3.1.5
H	L	L	3.1.6
H	L	H	3.1.7
H	H	L	3.1.8
H	H	H	3.1.9

#### 3.1.2 ALL ALARMS ON

The AC utility power has failed and the power supply has transferred to the inverter (standby) mode. There has been an overload at the output of the inverter causing the 60 VAC alarm to latch (this overload may have been momentary). Remove the overload and reset the power supply as in Section 1.7.3. If reset is still not possible, check the output fuse or circuit breaker and replace if necessary. As a final step, check the AC utility breaker mounted in the enclosure (some installations may have a separate service disconnect breaker mounted outside as well) to make sure it has not tripped.

#### 3.1.3 GEN PS, STANDBY ALARMS ON

The power supply is in the inverter mode, but there has been a previous GEN PS alarm condition which has not been reset. See

Section 3.1.5 for conditions which may cause this.

#### 3.1.4 GEN PS, 60 VAC ALARMS ON

The power supply has entered the SELF-TEST mode and promptly resumed AC utility power operation, due to a low 60 VAC output. Check the inverter circuitry for blown power transistors and the main power relay K1 for worn contacts.

#### 3.1.5 GEN PS ALARM ON

One of three conditions may cause this alarm to latch until reset. They are as follows:

1. Normal start-up condition - The AC utility power and the battery voltage are correct, but the standby light on the power supply keeps flashing (FLASHING alarm). Simply reset the flashing alarm as in Section 6.3.
2. Battery fuse or battery breaker open - When the power supply goes into the SELF-TEST mode and is forced into standby, there is an immediate return to AC utility power if the batteries have been disconnected. There is a subsequent FLASHING alarm as well as a GEN PS alarm. Reconnect the battery circuit by replacing the fuse or pushing in the breaker and reset the alarm as per Section 1.7.3.
3. Battery condition weak - The power supply has been forced into standby by the SELF-TEST mode and the batteries have not held up sufficiently for one-half hour. There has been a subsequent return to AC utility power. Reset the alarm as per Section 1.7.3 and monitor battery condition as the cells are recharging. The total battery voltage should quickly rise to around 39 volts unless the weather is extremely hot, in which case the temperature compensation of the RPM card tapers off the charge rate. Send service personnel to check battery condition (measure specific gravity of all cells) and top up the cells if there is any doubt.

#### 3.1.6 STANDBY, 60 VAC ALARMS ON

There has been a AC utility power failure and the power supply has gone into standby. The AC utility power remains down, and the RPM card sends back the above alarms to the status monitor. Check for a blown 60 VAC output fuse or a defective inverter power transistor.

#### 3.1.7 STANDBY ALARM ON

The power supply is in standby (running off the batteries) because there has been either a AC utility power failure or a forced inverter operation from the SELF-TEST mode. Reset the power supply as per Section 1.7.3. If this alarm remains on, this means that there is a power outage at that location and emergency generator may have to sent out should the outage be prolonged.

### 3.1.8 60 VAC ALARM ON

There are three conditions which may cause this alarm to latch:

1. The AC utility power is still on, but the power supply has entered the SELF-TEST mode. The 60 VAC output fuse has then failed (likely due to a short across the supply cable or an overload), followed by a transfer from inverter to AC utility power. Correct the fault condition, replace the output fuse, and reset the alarm as in Section 1.7.3.
2. The power supply has been running off AC utility power, but a fault on the 60 VAC output line has blown the fuse. Correct the fault and reset as in the previous paragraph.
3. The power supply has been operating normally, but there is an overload on the 60 VAC output. This may be in excess of 15 amps but is not enough to blow the fuse (or trip the output breaker, as the case may be). The 60 VAC output has dropped out of regulation and tripped the 60 VAC alarm. Repair the fault by reducing the loading on the output, replacing the fuse if weakened, and resetting the alarm as in Section 1.7.3.

### 3.1.9 ALL ALARMS OFF (HIGH)

The most likely condition is that everything is functioning properly. If in doubt, check the battery voltage and place the unit into standby using the status monitor terminal to force a TEST mode (see Section 1.7.3). Bring the unit out of TEST, and if everything is functioning, the alarms will remain high.

A probable fault condition which could mislead one into thinking everything is working is the loss of AC utility power and battery power to the power supply under test, with no loss of power to the status monitor transponder which is performing the measurements. In this situation, the measurement of an extremely low battery voltage (less than 20 volts) followed by a field inspection, could identify the fault.

APPENDICES

A. INPUT/OUTPUT OPTIONS OF THE VARIOUS STATUS MONITOR SYSTEMS

1. Texscan Vital Signs\*

The pinout configuration of the RPM logic board is identical to that used on the Texscan TDM-1A Transponder Data Module (this is part of the Vital Signs System but is mounted inside the Alpha power supply enclosure). The interconnection cable between the RPM and the TDM-1A is by means of a 12-wire harness terminated on both ends with an in-line mass termination type housing of the Amp or Molex variety, with 0.1" spacing between adjacent pins (see Alpha Drawing A5049). Care must be taken to insert the polarized housings correctly into their respective ports. If the housing does not go in all the way, it is probably inserted the wrong side up.

The Texscan unit used is a TDM-1A although other models may also be used with a reduction in monitoring functions. The following options must be specified at the time of ordering from Texscan (if they are required):

Option 1	ACVP (AC Voltage Probe)	measures 60 VAC output
Option 2	Temperature Probe	measures ambient temperature
Option 3	SC-1 Switch	controls the power supply
Harness 3	Interconnect Cable	connects TDM-1A to power supply

The Interconnect Cable is available as part of a cable kit when the RPM option is ordered from Alpha.

The following tests are performed by the Vital Signs software on the power supply.

Test	Command	Level Measured
1	Output Voltage	60 VAC
2	Battery Voltage	38 VDC
3	Standby Flag	Low = Standby
4	Tamper Flag	Low = Door Open
5	Output Current	15 A AC
6	Temperature	Relative Reading (not absolute degrees)
7	Inverter Health/Test	Low = Fail
8	Test On	Low = On

The following are external connections accessible on the TDM-1A for connection to the RPM board:

Pin	Function	Max. Allowable Level at Input of TDM-1A
1	Common	
2	Power Input	12 - 36 VDC
3	Not Used	
4	Output Voltage	38 VAC max **
5	Battery Voltage	38 VDC max **
6	Standby Flag	38 VDC max
7	Tamper Flag	38 VDC max
8	Output Current	15 VDC max ***
9	Not used	15 VDC max
10	Inverter Flag	15 VDC max
11	Test switch	15 VDC max
12	Ground, Common	

\*\* As these inputs will not accept greater than 38 volts, prescaling is provided on the RPM card (typically set to one-half scale). Further scaling is performed through Texscan software manipulation.

\*\*\* The scaling for output current is normally set for 0.4 volts per amp of load current

## B. LIST OF EQUIPMENT (TEXSCAN ONLY)

### 1. RPM CARD AND ACCESSORIES

- RPM Card Model RPM-681
- Tamper Switch Kit (Alpha Drawing A5005)
- TDM to RFC Coaxial Cable (Alpha Drawing A5007)
- TDM to RPM Wire Harness (Alpha Drawing A5049)
- RFC Output Filter (Alpha Drawing A2027)

### 2. RF COMMUNICATIONS MODEM AND ACCESSORIES

- PPI-1 Processor-to-Plant Interface
- TDM-1 Data Transceiver Module
- RS232 Interconnect Cable (Computer to PPI-1)

### 3. COMPUTER SYSTEM

- Apple II Plus Computer or Apple IIe
- Apple Disk II Floppy Disk Drive
- Apple Disk II Controller Card
- CCS Model 7710 Asynchronous Serial Interface for Apple
- CCS Model 7424 Calendar/Clock Module (optional)
- Video Monitor (black/white or color)
- Apple to Monitor Video Cable
- Texscan Vital Signs \* Software Disk

\* Texscan and Vital Signs are registered trademarks of Texscan Corporation.

Refer to Alpha Drawing B5040 to see how the above equipment is configured in a typical RPM test set-up.

CAUTION: TO AVOID HOOKING UP THE EQUIPMENT INCORRECTLY AND POSSIBLY CAUSING DAMAGE TO THE CIRCUITRY, REFER TO THE APPROPRIATE SECTION FOR SETTING UP EACH PIECE OF EQUIPMENT. IT IS ESPECIALLY IMPORTANT THAT CONNECTORS ARE PLUGGED INTO THEIR MATING PARTS PROPERLY AND WITH THE PROPER POLARIZATION.

For equipment to be used with other systems, consult the manufacturer.

NOTE: BATTERY TERMINAL STYLE MAY VARY

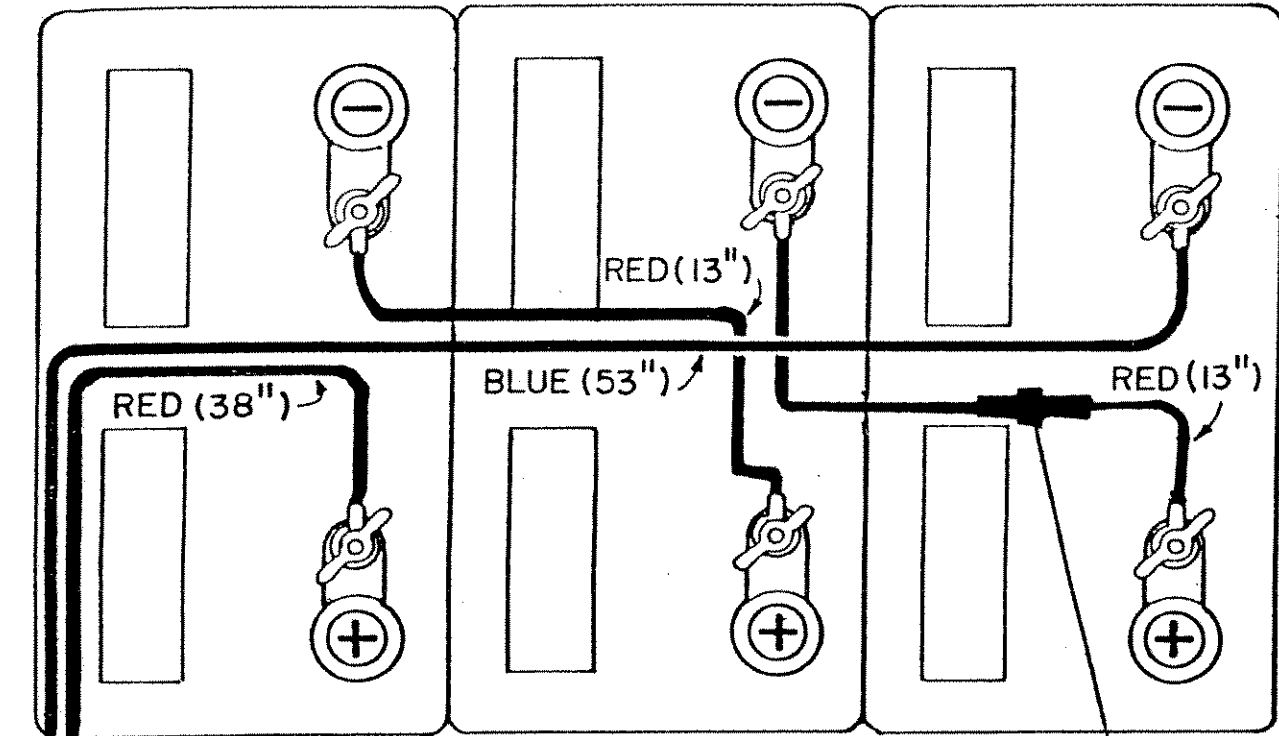

ROUTE WIRES THROUGH BATTERY-SHELF HOLE  
OR THROUGH CHANNEL

OBSERVE POLARITY

FOR AP660 ONLY:  
USE HEB-AA HOLDER  
AND BAF30 FUSE

FOR AP960 & AP960HE:  
USE HEJ-AA HOLDER  
AND APPROPRIATE  
TYPE SC FUSE

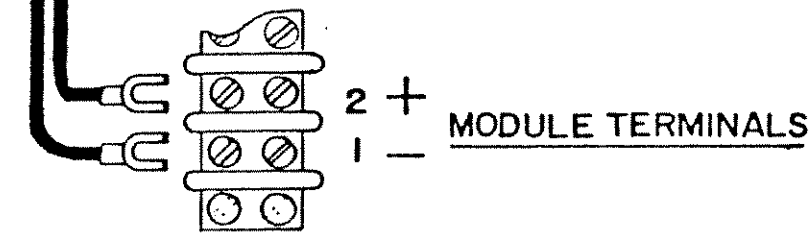

RECOMMENDED WIRE SIZE IS 10 AWG STRANDED TEW

ITEM	1	WIRE LENGTH CHANGED, BATTERIES RE-POSITIONED	SW	OCT 25/84	
REV.		DESCRIPTION	DRAWN	DATE	APPROVED
<b>ALPHA TECHNOLOGIES</b>			DRAWN	DATE	CONTRACT NO.
			SW	OCT. 13/81	
			DESIGN	DATE	PRODUCT REF.
					BCK
<b>TITLE BATTERY CONNECTION DIAGRAM</b>			APPROVED	DATE	SCALE
			JD	OCT. 13/81	N.T.S.
<b>MATERIAL N/A</b>			ISSUED	DATE	SHEET
					1 OF 1
<b>FINISH N/A</b>			<b>TOLERANCES N/A</b>		DRAWING NO.
					A1077

THESE DESIGNS & SPECIFICATIONS ARE THE PROPERTY OF ALPHA TECHNOLOGIES AND SHALL NOT BE COPIED OR USED FOR MANUFACTURING WITHOUT ITS WRITTEN CONSENT.

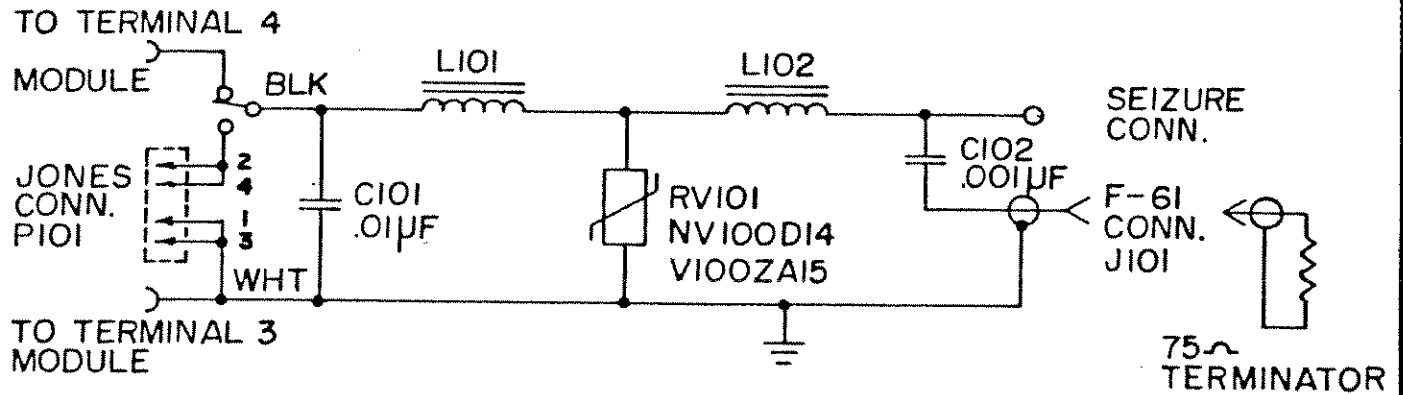
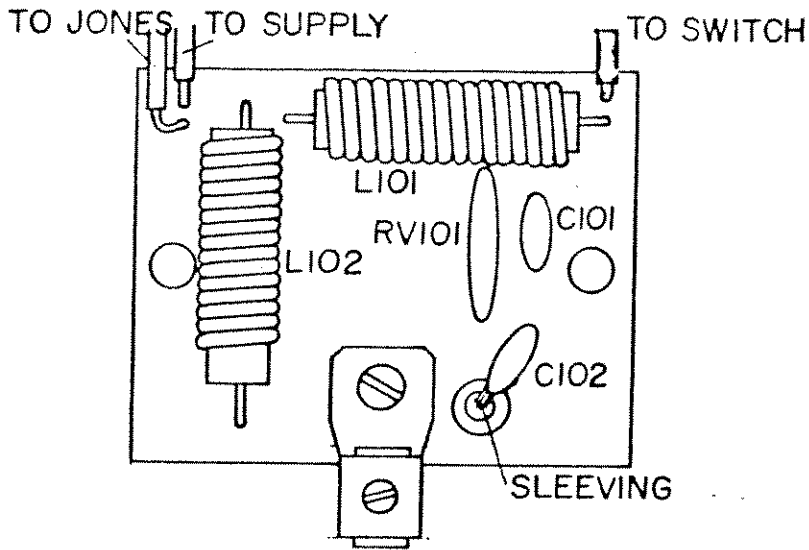

ITEM	1	RFC OPTION ADDED	DH	OCT. 4 /82	
REV.		DESCRIPTION	DRAWN	DATE	APPROVED
 <b>ALPHA TECHNOLOGIES</b>			DRAWN	DATE	CONTRACT NO.
			DH	OCT. 4/82	
			DESIGN	DATE	PRODUCT REF.
			SW	OCT 4/82	SPI
			APPROVED	DATE	SCALE
<b>TITLE</b> SPI/OUTPUT FILTER ASSEMBLY			SW	OCT 4/82	N.T.S.
			ISSUED	DATE	SHEET OF
MATERIAL		N/A	THESE DESIGNS & SPECIFICATIONS ARE THE PROPERTY OF ALPHA TECHNOLOGIES AND SHALL NOT BE COPIED OR USED FOR MANUFACTURING WITHOUT ITS WRITTEN CONSENT.		DRAWING NO.
FINISH		N/A			

# REVISIONS

LTR	DESCRIPTION	DATE	APPROVED
A	DWG. WAS 266-1 (A2027) REV. -	9/6/89	T.O.

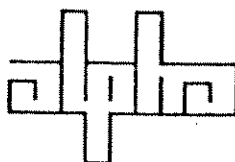
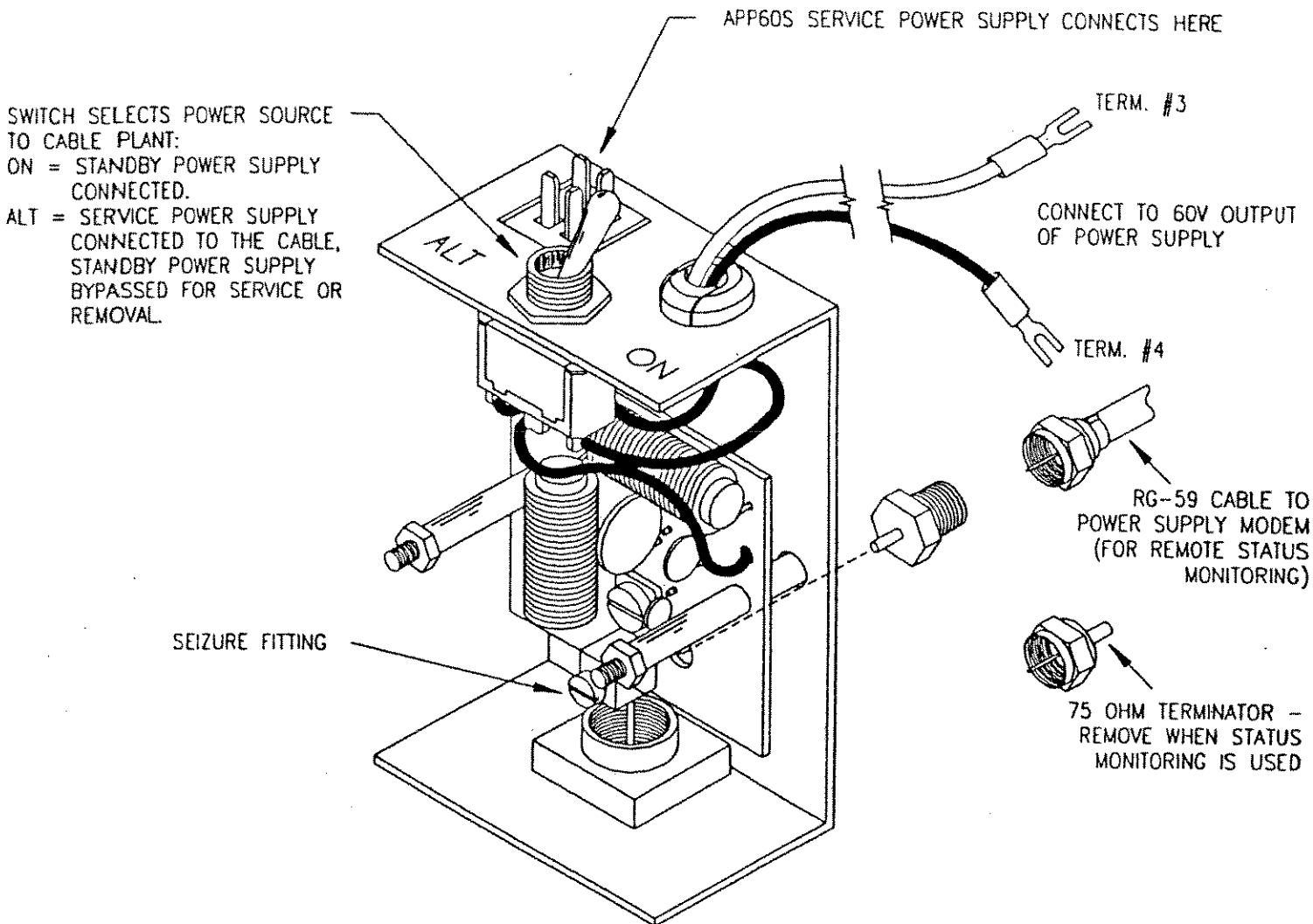

ALPHA  
TECHNOLOGIES

EXCEPT AS NOTED, DIM. ARE IN INCHES	MATERIAL: N/A
XXX = ± .010	
XX = ± .03	
ANGLES = ± 0°30'	FINISH: N/A
DESIGNS AND SPECIFICATIONS ARE THE PROPERTY OF: TECHNOLOGIES AND SHALL NOT BE COPIED OR USED FOR MANUFACTURING WITHOUT PRIOR WRITTEN CONSENT.	ALPHA TECHNOLOGIES 3767 ALPHA WAY BELLINGHAM, VA 98225 PHONE (206) 647-2360 FAX (206) 671-4936

TITLE		SPI/OUTPUT FILTER INSTALLATION	
A	DWG No. 020-019-C0 (266-1) (A2027)	REV	A
DWG BY: <i>Cherie Barth</i>		SCALE: N/A	
ACAD REF. FILE: SPIFLTR.DWG		SHEET 1 OF 1	
APPROVED BY: <i>T.OSTERMAN</i>			
APPROVAL DATE: <i>9/6/89</i>		RELEASE DATE:	

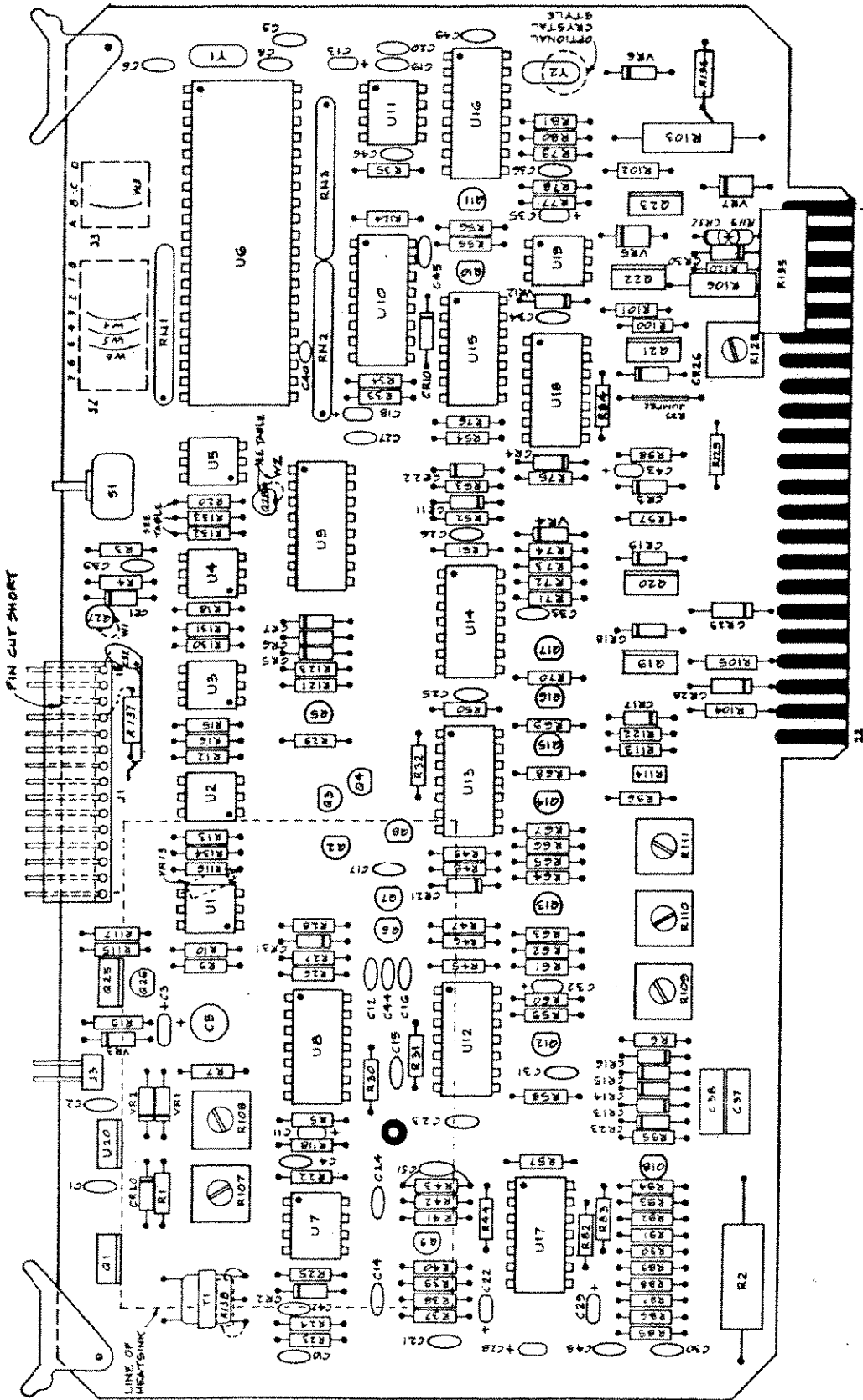

6	REV PER ECO 07-01/5	20	07-03-79	KN
7	REV PER ECO 08-01/8	20	08-01-78	BP
8	ECO DELAYED, AS PER ECO 08-16		MAY 9/85	
9	ECO DELAYED, AS PER ECO 08-16			
10	AS PER ECO 08-01			
11	AS PER ECO 08-01			

1	REV PER ECO 07-1/9	20	07-01-79	KN
2	REV PER ECO 07-1/9	20	07-01-79	KN
3	REV PER ECO 07-1/9	20	07-01-79	KN
4	REV PER ECO 07-1/9	20	07-01-79	KN
5	REV PER ECO 07-1/9	20	07-01-79	KN

**ALPHA TECHNOLOGIES**  
 TITLE COMPONENT LAYOUT, REV. 2, 11/80  
 RPM LOGIC CARD

4

3

2

1

REVISIONS

LTR	DESCRIPTION	DATE	APPROVED
A	REVISED & REDRAWN N. WAS A5005	83-06-01	KM JKL

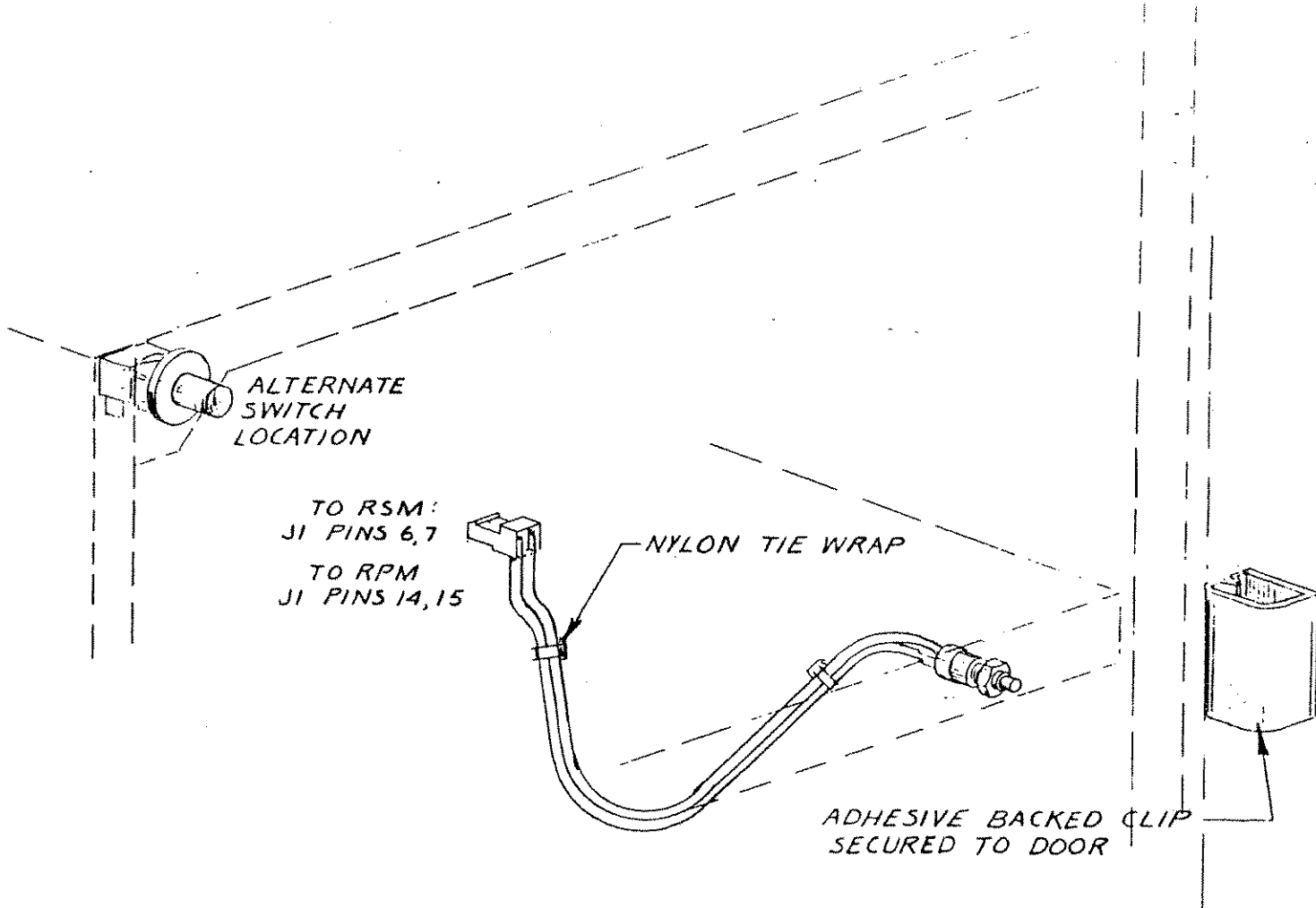

LTR	SIZE AND DESCRIPTION	PLATED THRU	QTY.
FINISHED HOLE LEGEND			
		<b>ALPHA TECHNOLOGIES</b>	
TITLE			
TAMPER SWITCH INSTALLATION			
ISSUED DATE	SIZE	DRAWING NO.	REV
	A	740-120-00	A
TOLERANCES	SCALE	SHEET /	OF /

DRAWN	WJD	89-06-01
CHECKED	KM	89-06-01
	JKL	
MATERIAL		
WEIGHT		
REDUCTION AVAILABLE		
740-120-20	THESE DESIGNS & SPECIFICATIONS ARE THE PROPERTY OF ALPHA TECHNOLOGIES AND SHALL NOT BE COPIED OR USED FOR MANUFACTURING WITHOUT ITS WRITTEN CONSENT.	
USED ON		
APPLICATION		

TERMINATIONS		
AMP	PREFERRED WIRE COLOR	SOURIAU
1	ORANGE	A
2	WHITE	B
3	BLACK	C
—	—	D
4	VIOLET	E
—	—	F
—	—	G
5	BLUE	H
6	BRN/WHT	J
7	ORG/WHT	K

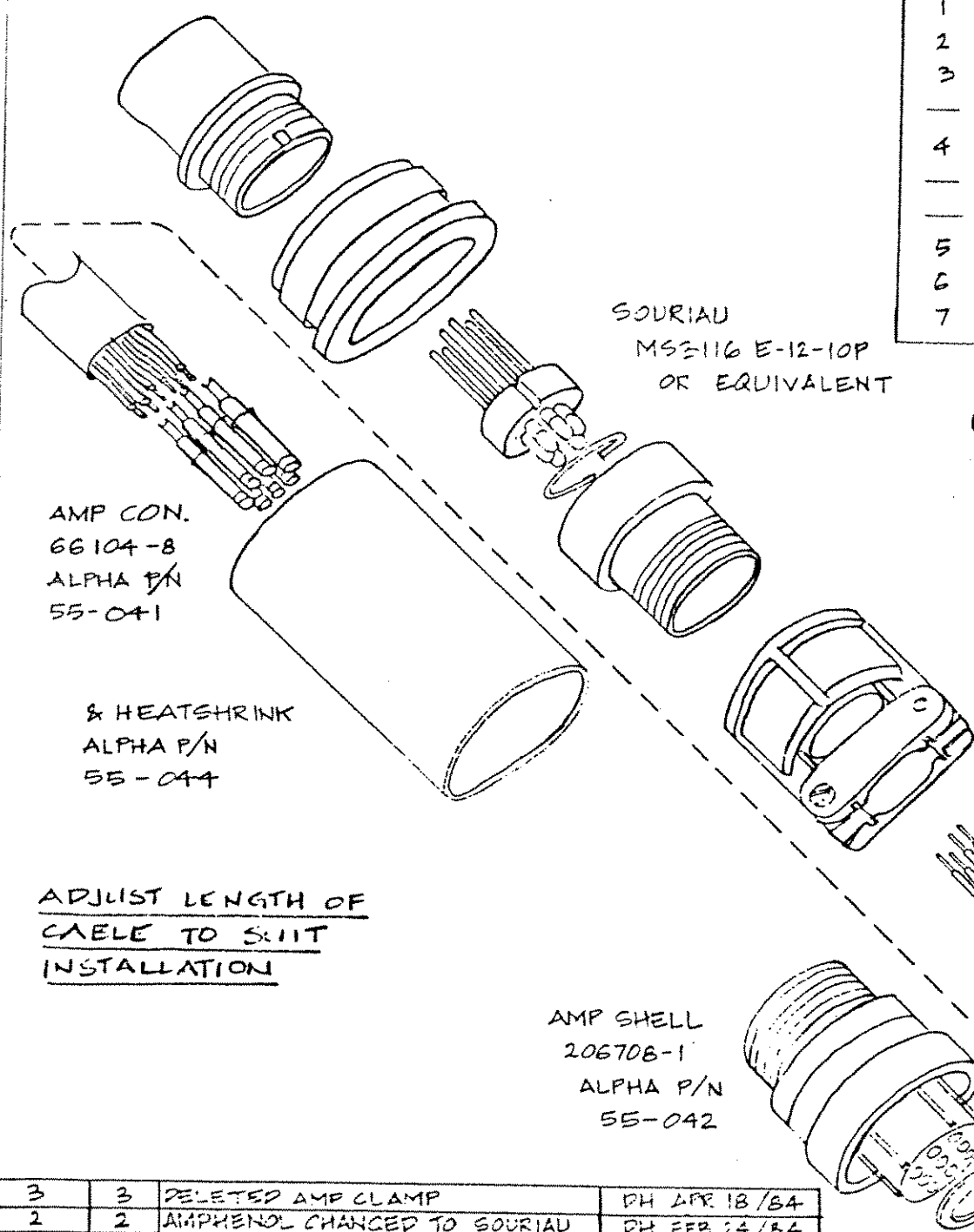

NOTE: EACH WIRE (EXCEPT FOR BLACK) IS PART OF A TWISTED PAIR TO REDUCE NOISE PICKUP. ALL THE BLACK WIRES OF THE TWISTED PAIRS AND THE SHIELD(S) MUST BE CONNECTED TO GROUND. (SOURIAU TERMINAL C)

RECOMMENDED CABLE:  
6-PAIR TWISTED SHIELDED  
BELDEN #9508,  
#8778 OR EQUIV.  
COLUMBIA 6017  
ALPHA P/N  
85-026

AMP CON.  
66104-8  
ALPHA P/N  
55-041

& HEATSHRINK  
ALPHA P/N  
55-044

ADJUST LENGTH OF  
CABLE TO SUIT  
INSTALLATION

AMP SHELL  
206708-1  
ALPHA P/N  
55-042

AMP WASHER  
206403-4  
ALPHA P/N 55-043

3	3	DELETED AMP CLAMP	DH APR 18/84
2	2	AMPHENOL CHANGED TO SOURIAU	DH FEB 24/84
1	1	CABLE LENGTH CHANGED FROM 15FT TO 25FT	

ITEM	REV.	DESCRIPTION
 <b>ALPHA TECHNOLOGIES</b>		
<b>TITLE</b> INTERFACE CABLE ASSEMBLY ALPHA-TD-CENTURY III STATUS MONITOR		
<b>MATERIAL</b> N/A		THESE DESIGNS & SPECIFICATIONS ARE THE PROPERTY OF ALPHA TECHNOLOGIES AND SHALL NOT BE COPIED OR USED FOR MANUFACTURING WITHOUT ITS WRITTEN CONSENT.
<b>FINISH</b> N/A		

DH	DATE	APPROVED
DH	NOV. 1 / 82	CONTRACT NO.
DESIGN	DATE	PRODUCT REF.
APPROVED	DATE	SCALE
SW	FEB. 24 / 84	APPROX. 1:1
ISSUED	DATE	1 SHEET OF 1
TOLERANCES	N/A	DRAWING NO.
		A5009

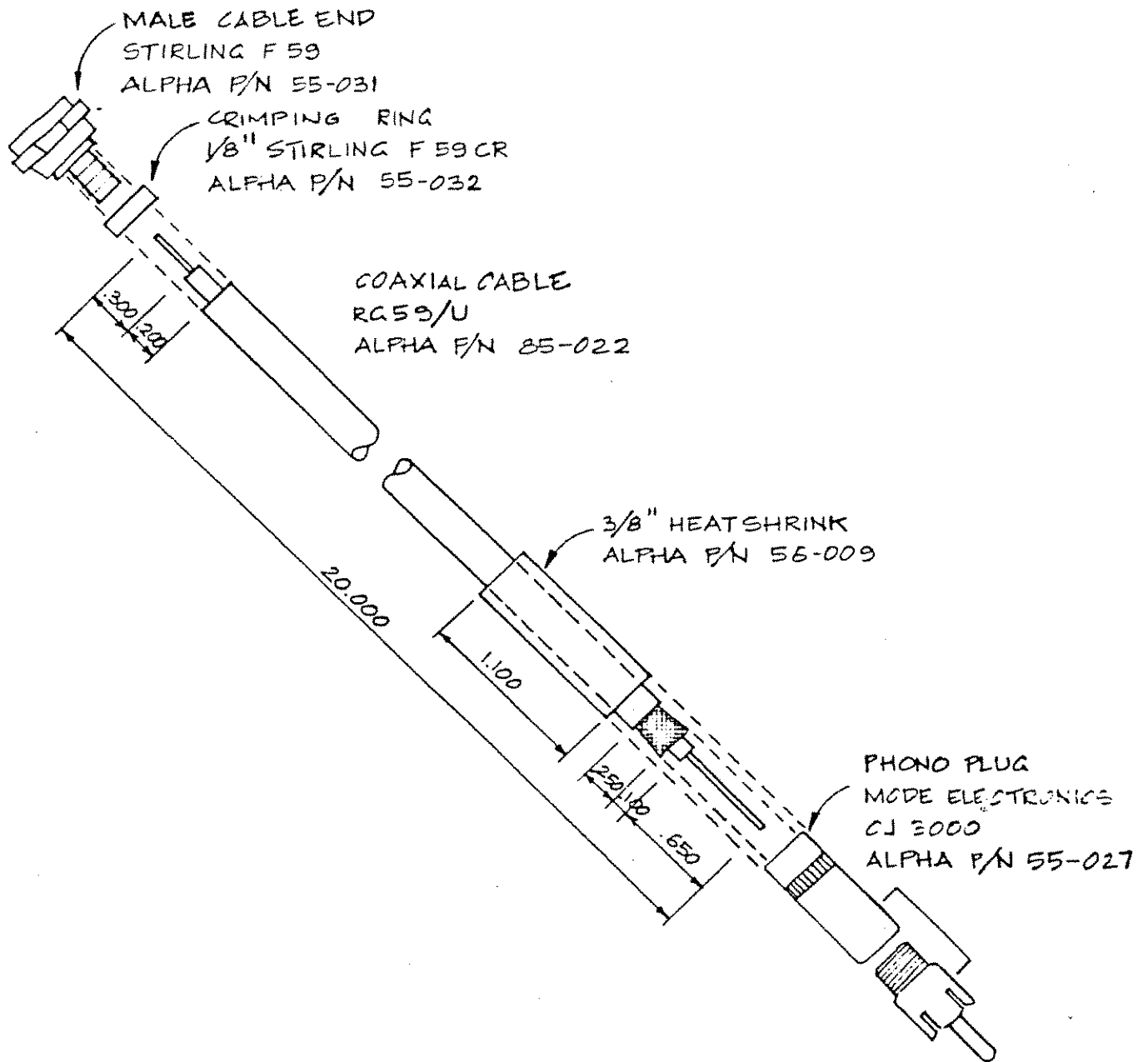

ITEM	REV.	DESCRIPTION	DRAWN	DATE	APPROVED
 <b>ALPHA TECHNOLOGIES</b>			DRAWN	DATE	CONTRACT NO.
			DH	OCT.18/82	
TITLE INTERCONNECT CABLE, DTR/TDM TO RFC			DESIGN	DATE	PRODUCT REF.
			SW		RSM/RPM
MATERIAL N/A			APPROVED	DATE	SCALE
			SW	OCT 18/82	1:1
FINISH N/A			ISSUED	DATE	1 SHEET OF 1
			TOLERANCES		DRAWING NO.
			N/A		A5007

THESE DESIGNS & SPECIFICATIONS ARE THE PROPERTY OF ALPHA TECHNOLOGIES AND SHALL NOT BE COPIED OR USED FOR MANUFACTURING WITHOUT ITS WRITTEN CONSENT.

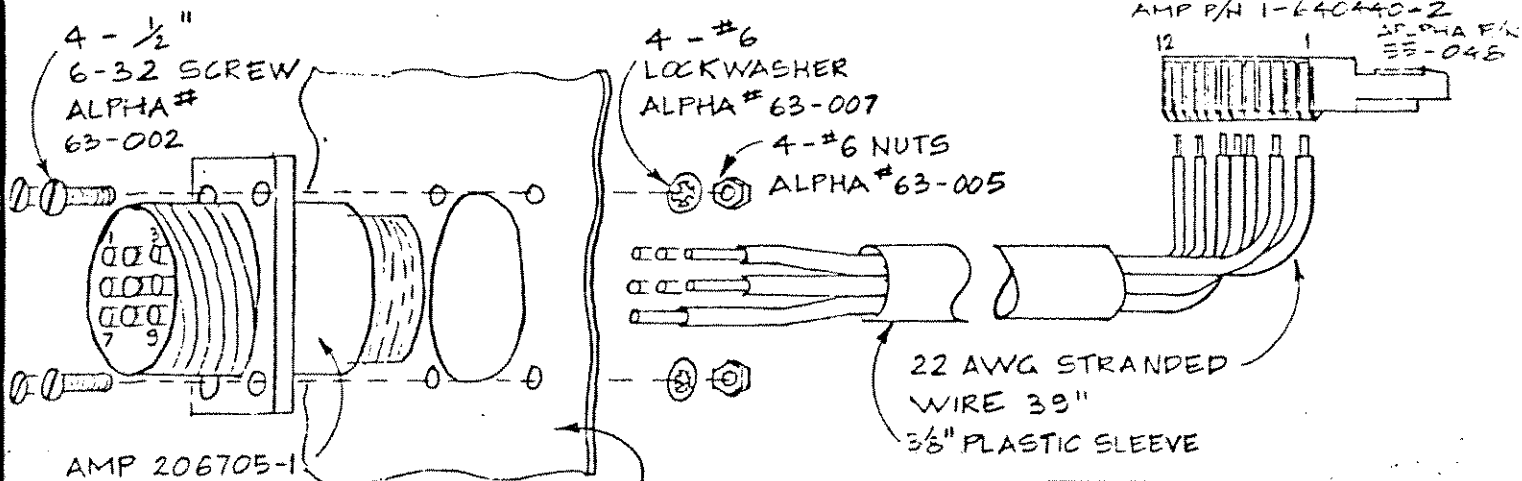

AMP 206705-1  
SILICONE  
SEAL TO  
ENCLOSURE

ENCLOSURE  
(BOTTOM OR REAR)

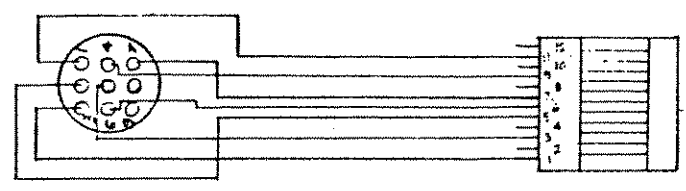

TERMINATIONS	
AMP CIRCULAR	AMP INLINE
1	11
2	5
3	1
4	9
5	3
6	6
7	7

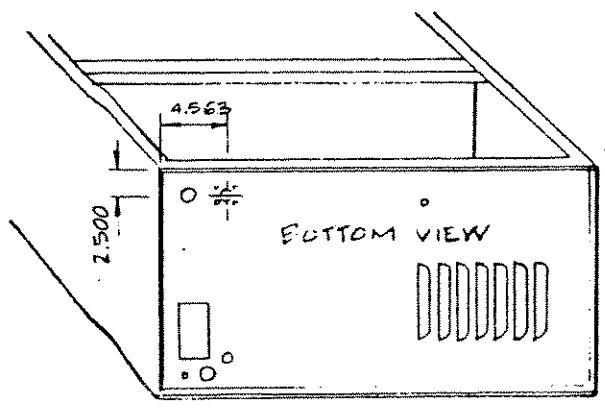

PME ENCLOSURE

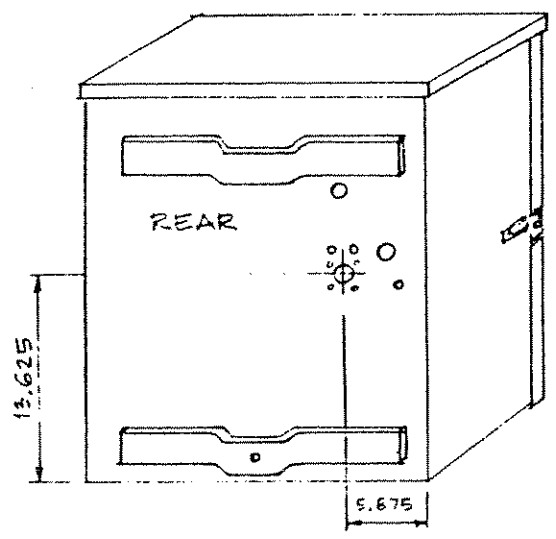

FWE ENCLOSURE

1	1	CHANGED FWE MOUNTING	PH	APR 15 / 85	
ITEM	REV.	DESCRIPTION	DRAWN	DATE	APPROVED
<b>ALPHA TECHNOLOGIES</b> TITLE ENCLOSURE CABLE ASSEMBLY ALPHA - TO-CENTURY III STATUS MONITOR			DH	JAN. 12 / 83	CONTRACT NO.
			DESIGN		PRODUCT REF. RPM
			APPROVED	DATE	SCALE N.T.S.
			SW	FEB 23 / 84	
MATERIAL	N/A	THESE DESIGNS & SPECIFICATIONS ARE THE PROPERTY OF ALPHA TECHNOLOGIES AND SHALL NOT BE COPIED OR USED FOR MANUFACTURING WITHOUT ITS WRITTEN CONSENT.	ISSUED	DATE	1 SHEET OF 1
FINISH	N/A		TOLERANCES	N/A	DRAWING NO. A5016

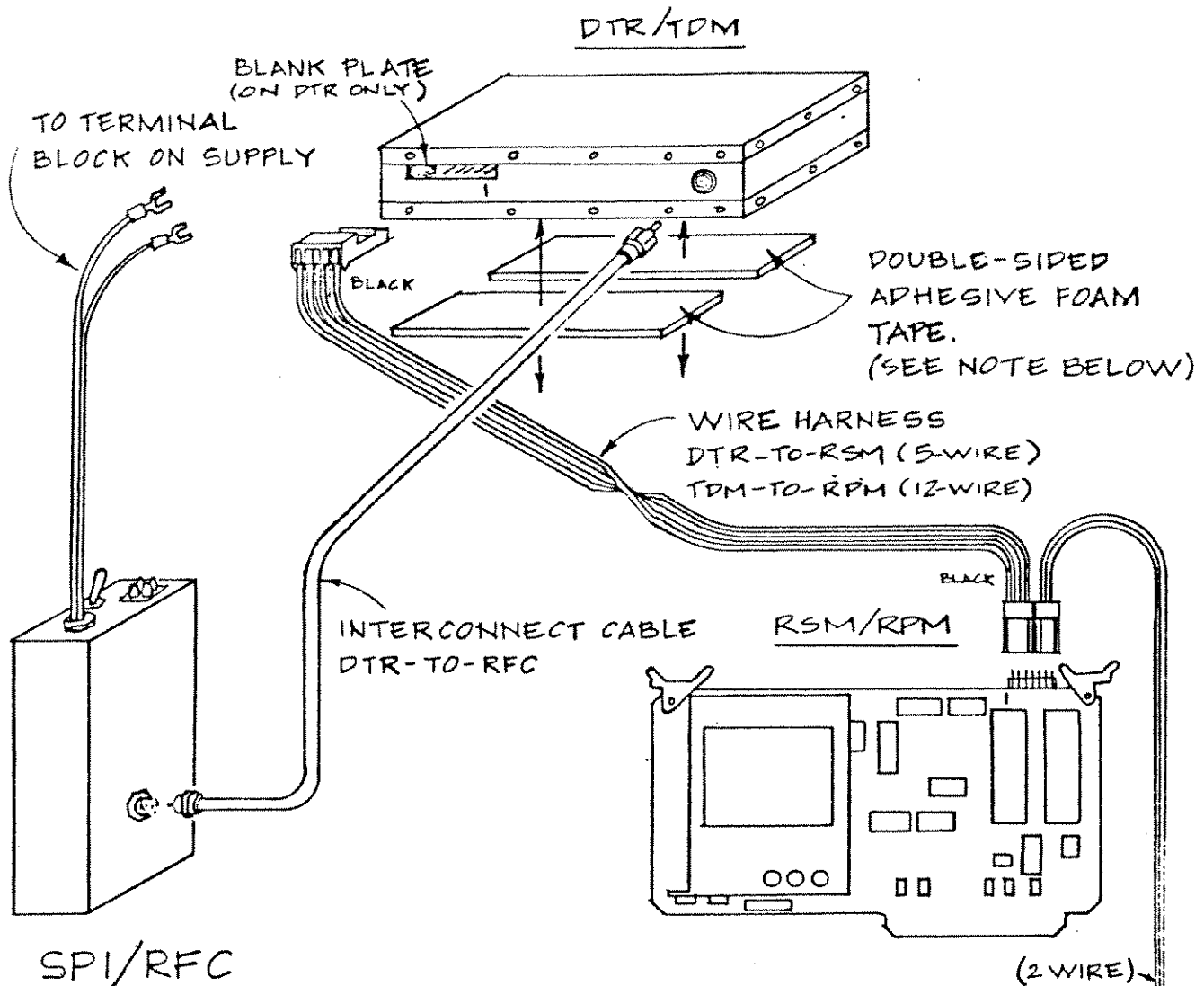

SPI/RFC

NOTE: AFFIX DTR-1 TO CIRCUIT BREAKER HOUSING BY CLEANING BOTH SURFACES OF DIRT AND GREASE AND USING 2 PCS OF 1/16" x 1/2" x 3" DOUBLE-SIDED ADHESIVE FOAM TAPE. ALPHA P/N 63-094

ITEM	REV.	DESCRIPTION	DRAWN	DATE	APPROVED
 <b>ALPHA TECHNOLOGIES</b>			DRAWN	DATE	CONTRACT NO.
			DH	MAR. 7/83	
			DESIGN	DATE	PRODUCT REF.
			SW		RSM/RPM
			APPROVED	DATE	SCALE
			SW	MAR 7/83	N.T.S.
TITLE <b>DTR/TDM INSTALLATION DIAGRAM</b>			ISSUED	DATE	1 SHEET OF 1
			TOLERANCES		DRAWING NO.
MATERIAL	N/A	THESE DESIGNS & SPECIFICATIONS ARE THE PROPERTY OF ALPHA TECHNOLOGIES AND SHALL NOT BE COPIED OR USED FOR MANUFACTURING WITHOUT ITS WRITTEN CONSENT.	N/A		A5021
FINISH	N/A				

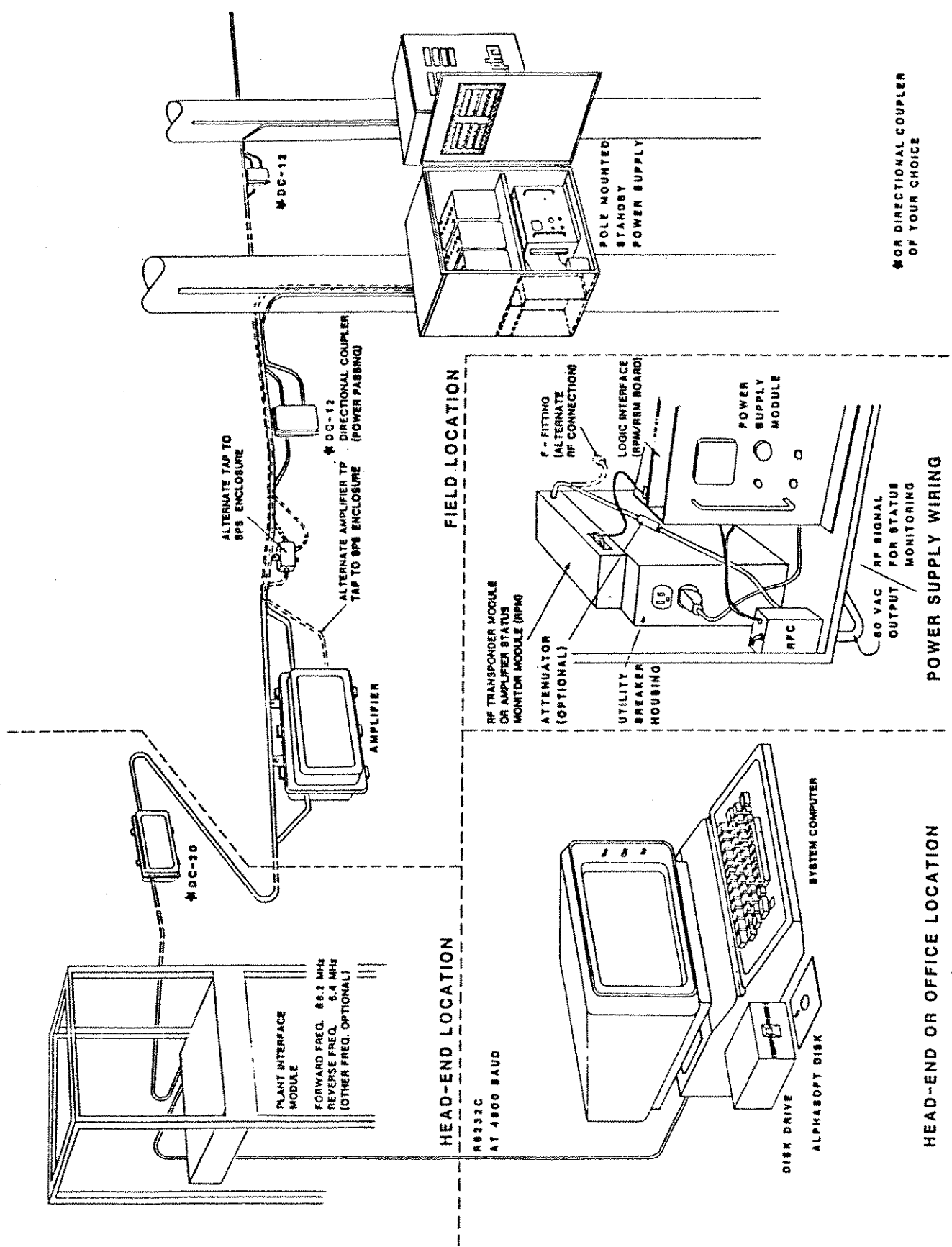

PLANT INTERFACE  
MODULE  
FORWARD FREQ. 88.2 MHz  
REVERSE FREQ. 5.4 MHz  
(OTHER FREQ. OPTIONAL)

HEAD-END LOCATION  
R8232C  
AT 4800 BAUD

FIELD LOCATION

RF TRANSDUCER MODULE  
OR AMPLIFIER STATUS  
MONITOR MODULE (RPM)

ATTENUATOR  
(OPTIONAL)

UTILITY  
BREAKER  
HOUSING

F-FITTING  
(ALTERNATE  
RF CONNECTION)

LOGIC INTERFACE  
(RPM/RSM BOARD)

POWER  
SUPPLY  
MODULE

60 VAC / RF SIGNAL  
OUTPUT /  
MONITORING

HEAD-END OR OFFICE LOCATION

POWER SUPPLY WIRING

FOR DIRECTIONAL COUPLER  
OF YOUR CHOICE

POLE MOUNTED  
STANDBY  
POWER SUPPLY

HEAD END

FIELD LOCATION

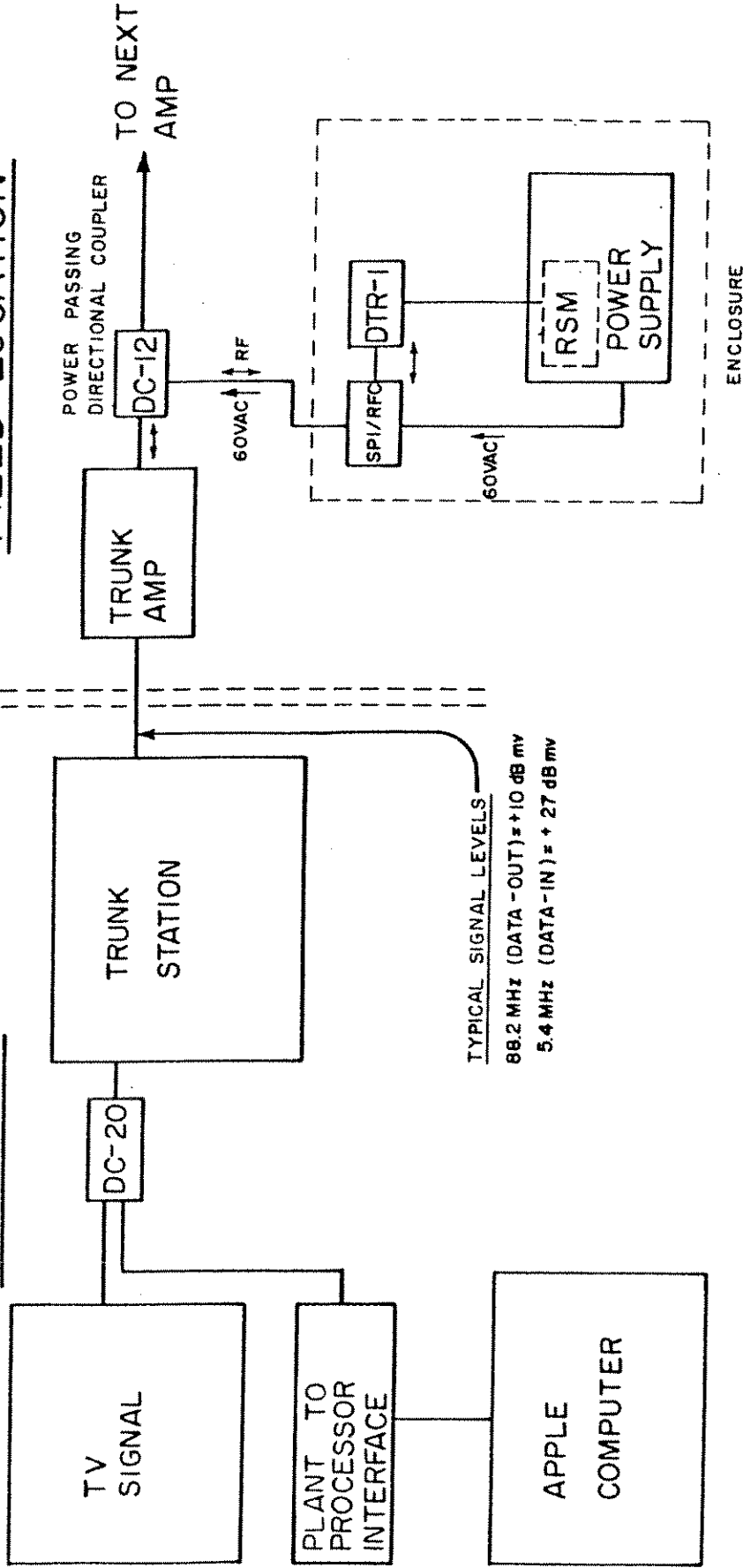

NOTE: RPM LOGIC CARD MAY REPLACE RSM. USE APPROPRIATE TRANSPONDER IN PLACE OF DTR-1.

ITEM	REV.	DESCRIPTION	DRAWN	DATE	APPROVED
CONTRACT NO.		THESE DESIGNS & SPECIFICATIONS ARE THE PROPERTY OF ALPHA TECHNOLOGIES AND SHALL NOT BE COPIED OR USED FOR MANUFACTURING WITHOUT ITS WRITTEN CONSENT.	DH	MAR.15/83	SCALE N/A
PRODUCT REF. RSM/RPM			DESIGN	DATE	SHEET 1 OF
MATERIAL N/A			APPROVED	DATE	
FINISH N/A			Sw	MAR.15/83	
TOLERANCES N/A		ISSUED	DATE		
<p><b>Alpha Technologies</b></p> <p>TITLE TYPICAL INSTALLATION BLOCK DIAGRAM</p>					

HEAD END

FIELD LOCATION

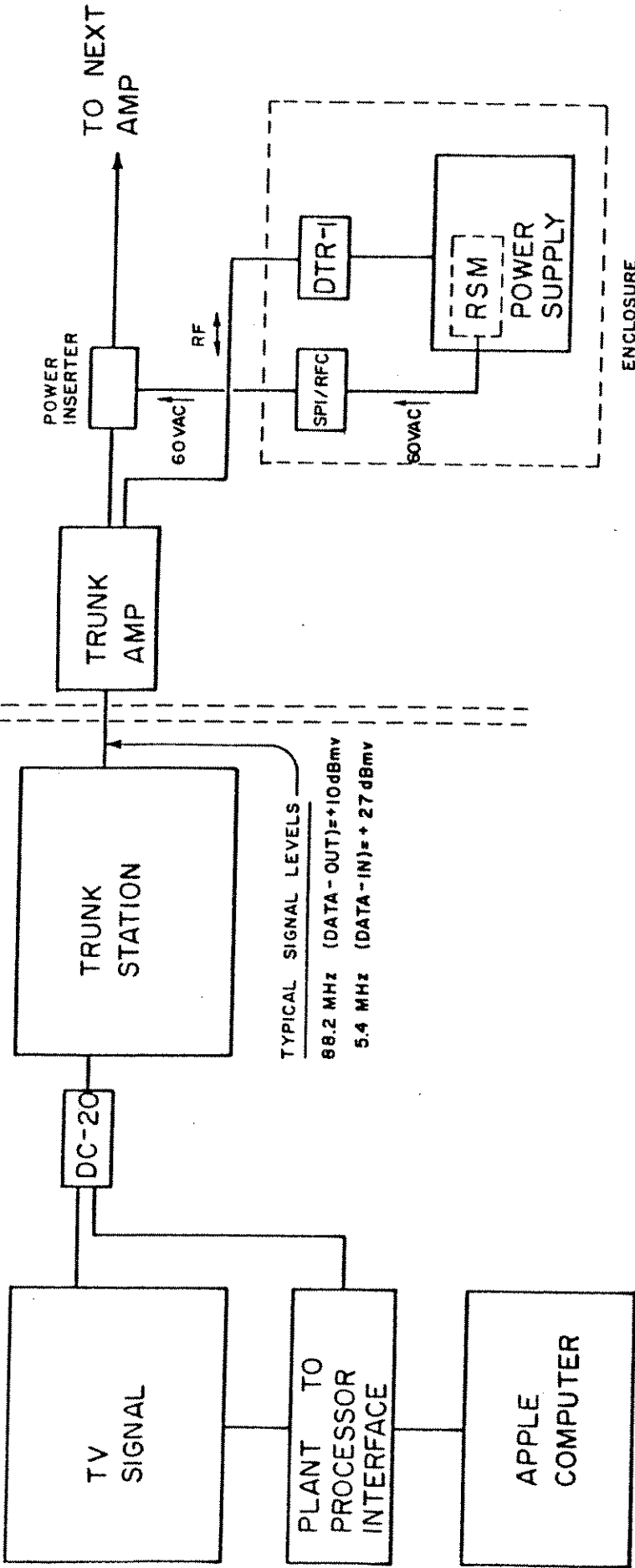

NOTE: RPM LOGIC CARD MAY REPLACE RSM. USE APPROPRIATE TRANSPONDER IN PLACE OF DTR-1.

ITEM	REV.	DESCRIPTION	DRAWN	DATE	APPROVED
CONTRACT NO.		THESE DESIGNS & SPECIFICATIONS ARE THE PROPERTY OF ALPHA TECHNOLOGIES AND SHALL NOT BE COPIED OR USED FOR MANUFACTURING WITHOUT ITS WRITTEN CONSENT.	DRAWN	DATE	SCALE
PRODUCT REF. RSM/RPM			DH	MAY 5/83	N/A
MATERIAL			N/A	DESIGN	DATE
FINISH		N/A	APPROVED	DATE	SHEET OF
TOLERANCES		N/A	ISSUED	DATE	DRAWING NO.
					A5031

**Alpha** ALPHA TECHNOLOGIES  
 TITLE ALTERNATE INSTALLATION  
 BLOCK DIAGRAM

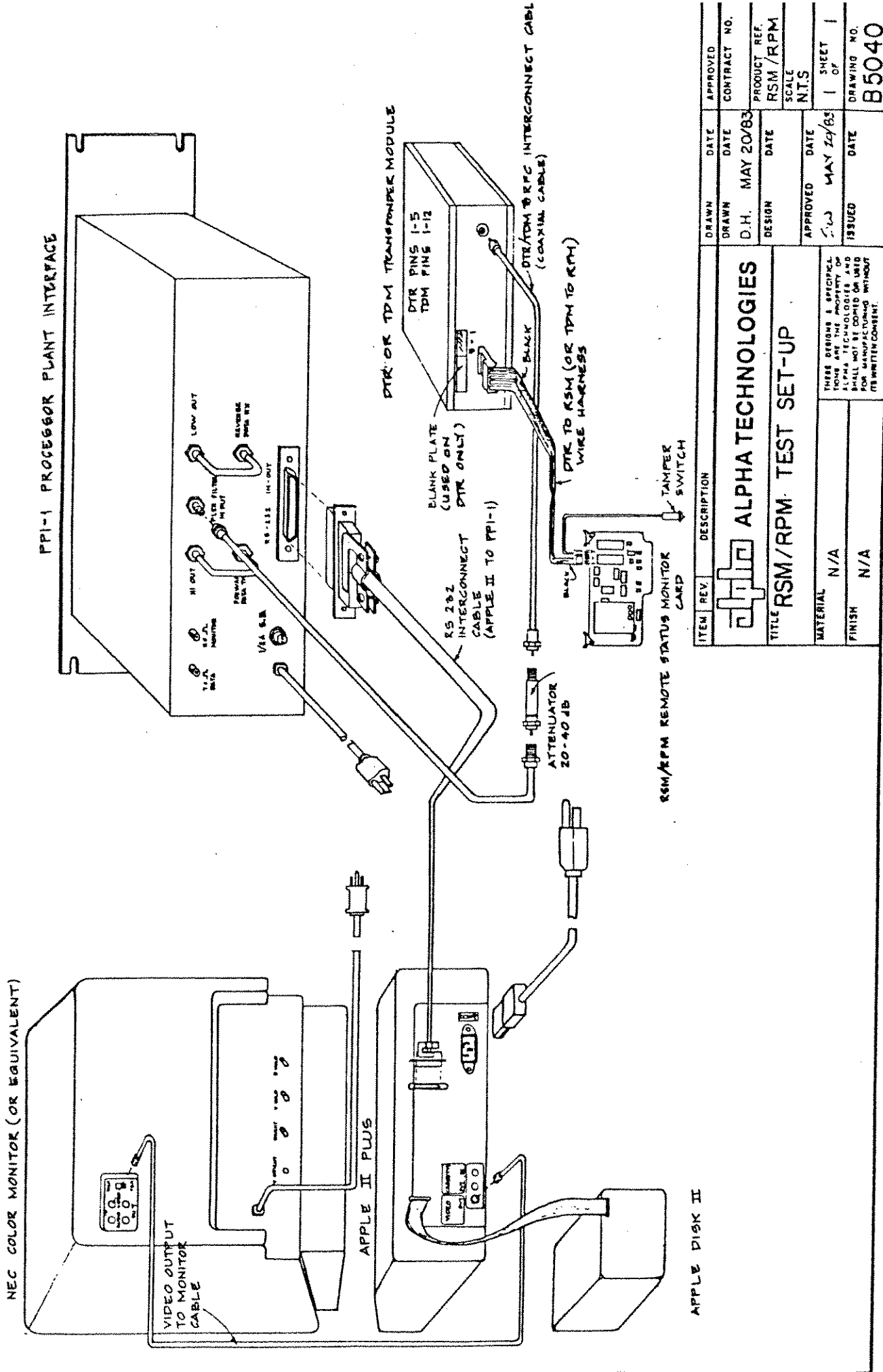

ITEM	REV	DESCRIPTION	DRAWN	DATE	APPROVED	CONTRACT NO.
 <b>ALPHA TECHNOLOGIES</b>			D.H.	MAY 20/83		
			DESIGN	DATE		PRODUCT REF.
TITLE			APPROVED	DATE	SHEET	OF
RSM/RPM TEST SET-UP			D.W.	MAY 19/83	1	1
MATERIAL			ISSUED	DATE	DRAWING NO.	
N/A					B5040	
FINISH			<small>THESE DESIGNS &amp; SPECIFICATIONS ARE THE PROPERTY OF ALPHA TECHNOLOGIES AND SHALL NOT BE COPIED OR USED FOR MANUFACTURING WITHOUT ITS WRITTEN CONSENT.</small>			
N/A						

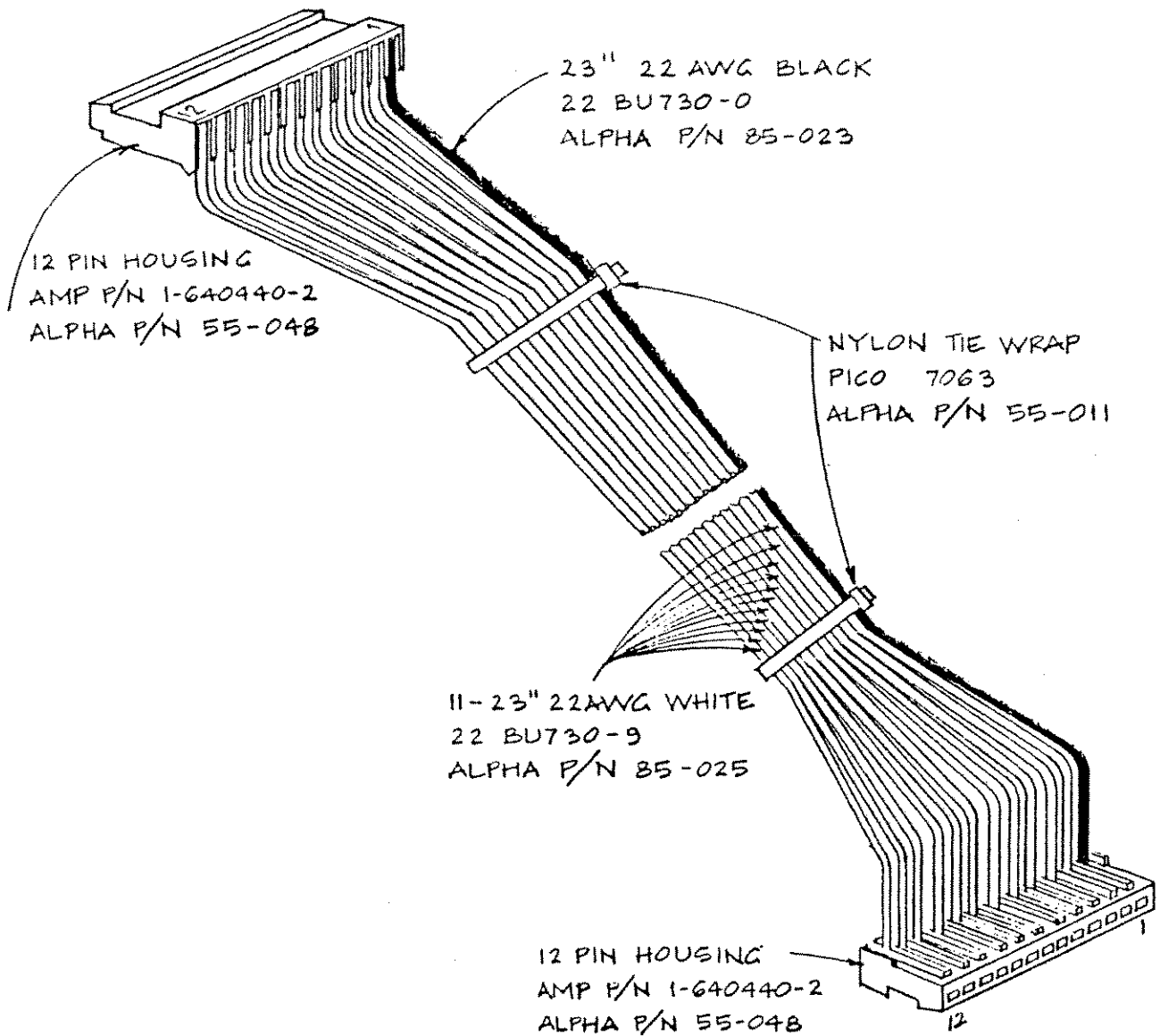

ITEM	REV.	DESCRIPTION	DRAWN	DATE	APPROVED
 <b>ALPHA TECHNOLOGIES</b>			DRAWN	DATE	CONTRACT NO.
			DH	OCT. 3/83	
<b>TITLE WIRE HARNESS, TDM-ITO RPM</b>			DESIGN	DATE	PRODUCT REF.
			SW		RPM
<b>MATERIAL N/A</b>			APPROVED	DATE	SCALE
			SW	OCT 3/83	N.T.S.
<b>FINISH N/A</b>			ISSUED	DATE	SHEET OF
					1 OF 1
<small>THESE DESIGNS &amp; SPECIFICATIONS ARE THE PROPERTY OF ALPHA TECHNOLOGIES AND SHALL NOT BE COPIED OR USED FOR MANUFACTURING WITHOUT ITS WRITTEN CONSENT.</small>			TOLERANCES	SIZE	DRAWING NO. REV
			N/A	A	496-10 -

REVISIONS

LTR	DESCRIPTION	DATE	APPROVED
A	REVISED AND REDRAWN. NOTES REWRITTEN. DWG. No WAS 316-1 (A5050)	89-02-14	BY J.

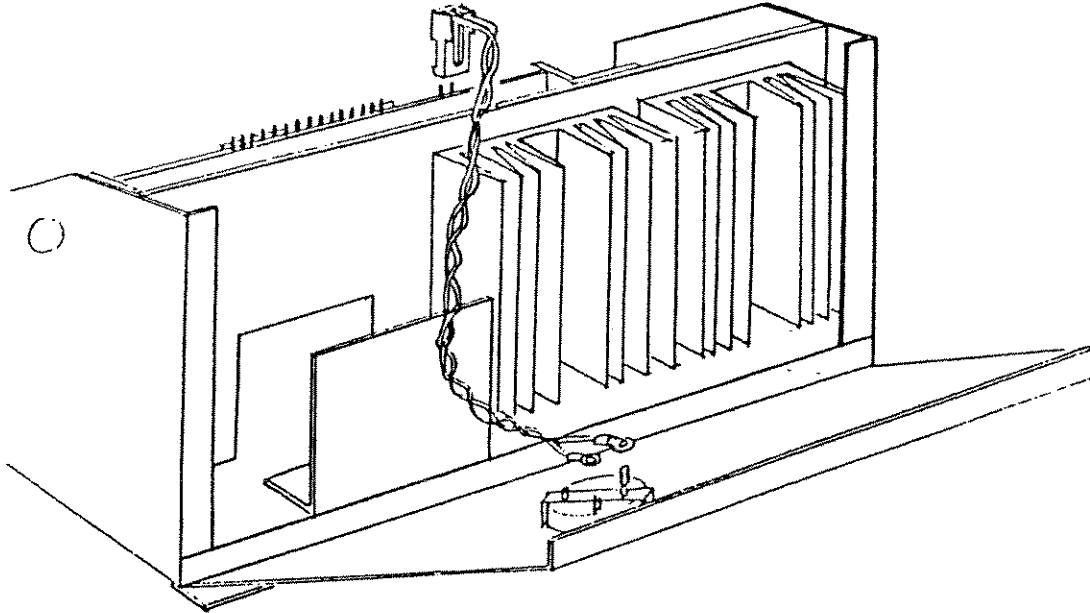

INSTALLATION PROCEEDURE, CURRENT SENSE CABLE, RPM

1. Remove the 5 screws securing the front panel of the power module.
2. Connect the two crimp connectors at one end of the current sense cable to the two electrical terminals of the output ammeter; it doesn't matter which wire goes to which terminal
3. Plug the two position connector at the other end of the current sense cable to into the two position connector at the top edge of the RPM control card; (J3).
4. If recalibration is necessary, refer to the RPM instruction manual.

LTR		SIZE AND DESCRIPTION	PLATED THRU	QTY.
FINISHED HOLE LEGEND				
DRAWN	WD	89-02-14		
CHECKED	B.Y.	89-02-21		
 <b>ALPHA TECHNOLOGIES</b>				
TITLE				
INSTALLATION PROCEDURE CURRENT SENSE CABLE				
ISSUED DATE		SIZE	DRAWING NO.	REV
		A	870-100-CO	A
TOLERANCES		SCALE	SHEET	OF
			1	1
870-100-10	THESE DESIGNS & SPECIFICATIONS ARE THE PROPERTY OF ALPHA TECHNOLOGIES AND SHALL NOT BE COPIED OR USED FOR MANUFACTURING WITHOUT ITS WRITTEN CONSENT.			
USED ON				
APPLICATION				

CENTURY III  
TRUNK AMPLIFIER

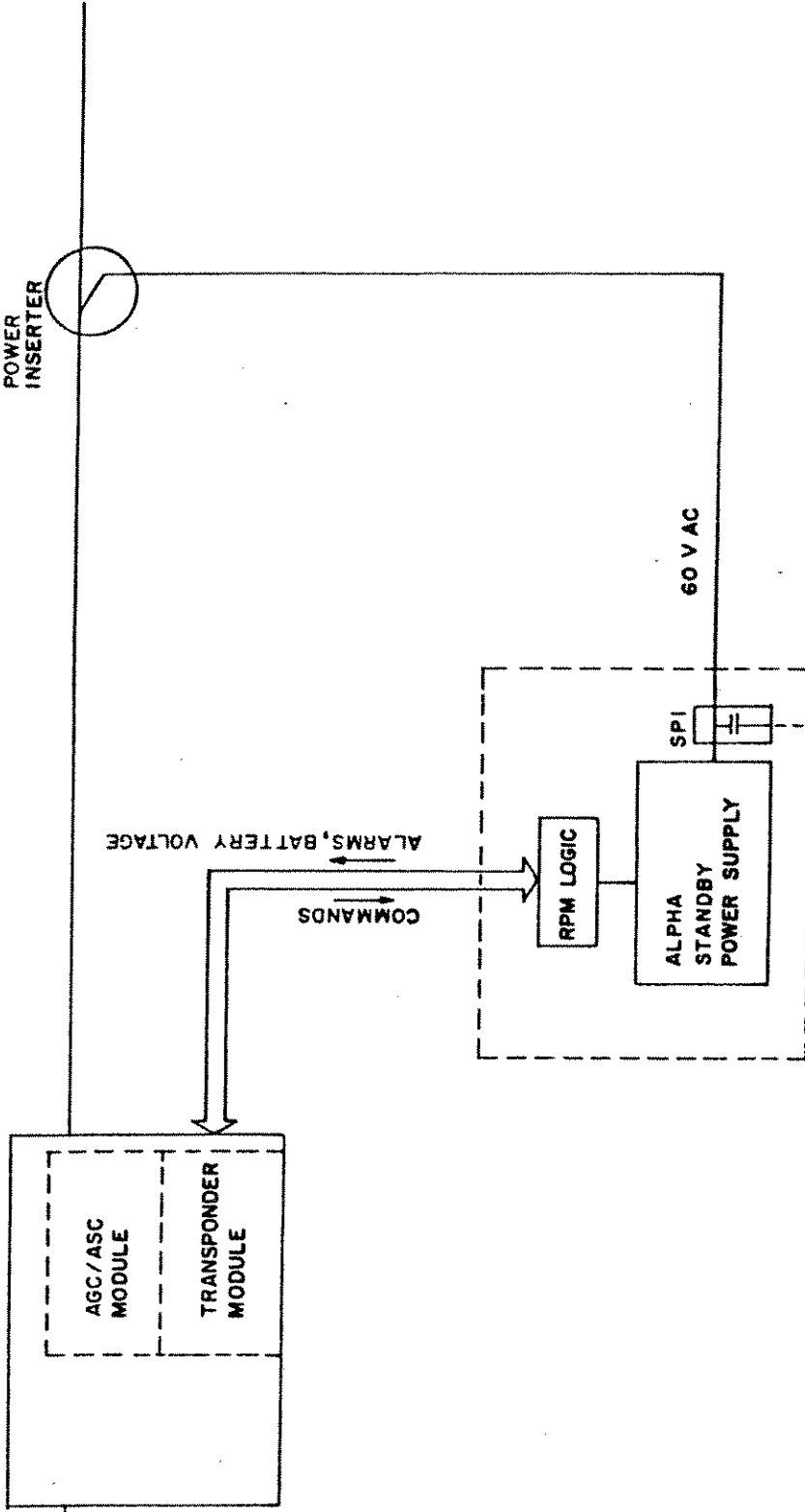

DRAWN	DATE	APPROVED
DH	FEB 24/84	SCALE N/A
DESIGN	DATE	
APPROVED	DATE	1 SHEET OF
ISSUED	DATE	DRAWING NO.
		A5056

ITEM	REV.	DESCRIPTION
CONTRACT NO.		THESE DESIGNS & SPECIFICATIONS ARE THE PROPERTY OF ALPHA TECHNOLOGIES AND SHALL NOT BE COPIED OR USED FOR MANUFACTURING WITHOUT ITS WRITTEN CONSENT.
PRODUCT REF. RPM		
MATERIAL	N/A	
FINISH	N/A	
TOLERANCES	N/A	

**Alpha** ALPHA TECHNOLOGIES  
 TITLE TYPICAL STATUS MONITORING CONFIGURATION  
 ALPHA/CENTURY III (EXTERNAL TRANSPONDER)

TRUNK CABLE

POWER PASSING  
DIRECTIONAL COUPLER  
DC-12

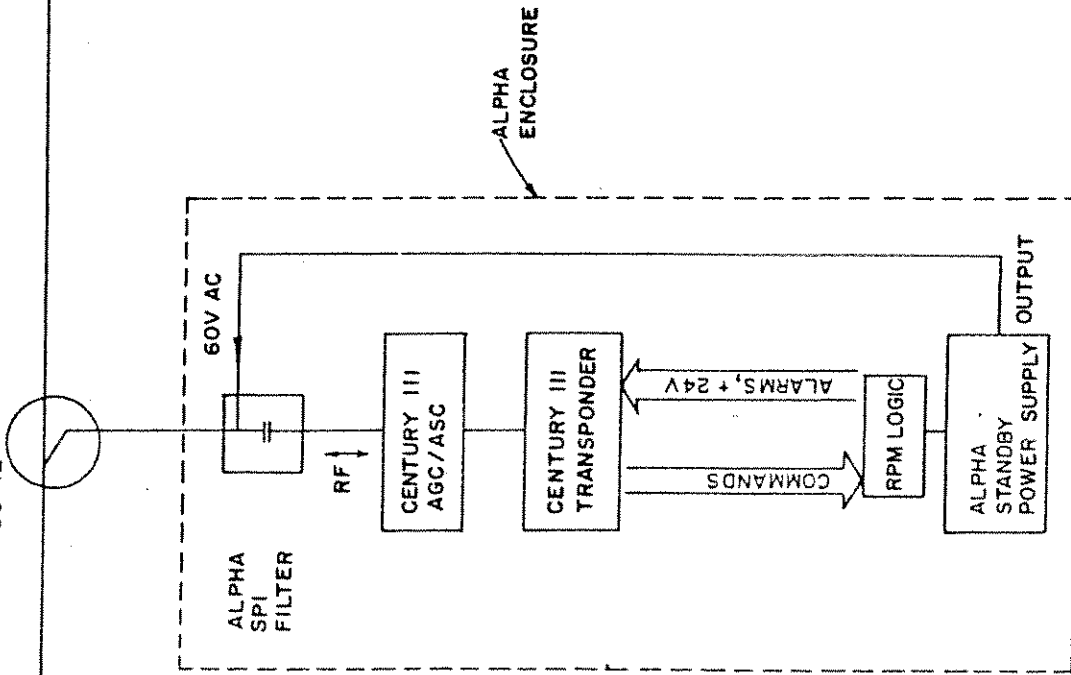

ITEM	REV.	DESCRIPTION	DRAWN	DATE	APPROVED
CONTRACT NO.		THESE DESIGNS & SPECIFICATIONS ARE THE PROPERTY OF ALPHA TECHNOLOGIES AND SHALL NOT BE COPIED OR USED FOR MANUFACTURING WITHOUT ITS WRITTEN CONSENT.	DH	FEB 24/84	SCALE N/A
PRODUCT REF. RPM			DESIGN	DATE	
MATERIAL		N/A	APPROVED	DATE	1 SHEET OF
FINISH		N/A	ISSUED	DATE	DRAWING NO.
TOLERANCES		N/A			A5057

**Alpha** ALPHA TECHNOLOGIES

TITLE TYPICAL STATUS MONITORING  
CONFIGURATION  
ALPHA/CENTURY III (INTERNAL TRANSPONDER)

4

3

2

1

REVISIONS

LTR	DESCRIPTION	DATE	APPROVED

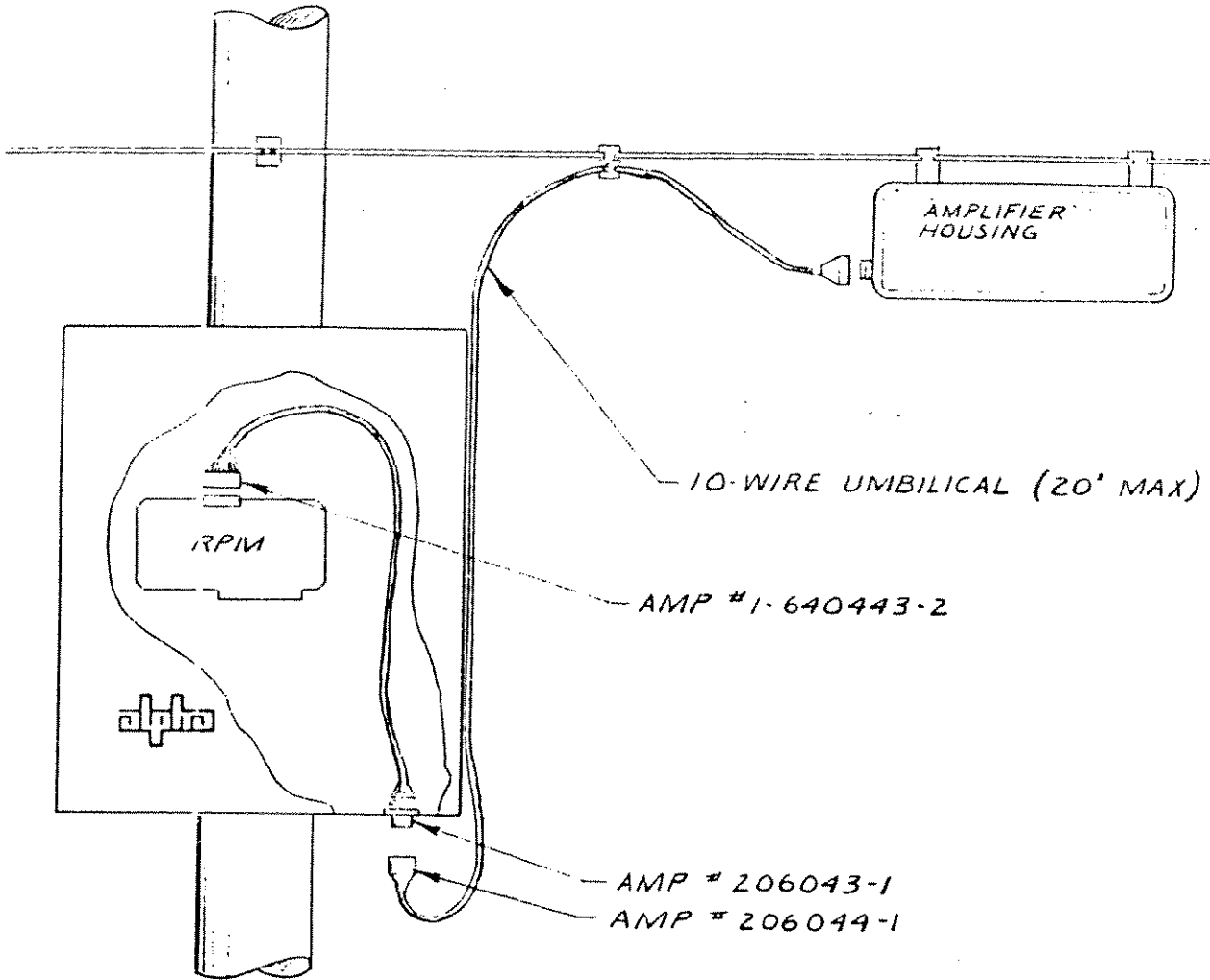

LTR	SIZE AND DESCRIPTION	PLATED THRU	QTY.
FINISHED HOLE LEGEND			

	DRAWN <i>WJD</i>	<i>87-12-22</i>
	CHECKED <i>Km</i>	<i>87-12-22</i>
	MATERIAL	
	WEIGHT	
	REDUCTION AVAILABLE	
	THESE DESIGNS & SPECIFICATIONS ARE THE PROPERTY OF ALPHA TECHNOLOGIES AND SHALL NOT BE COPIED OR USED FOR MANUFACTURING WITHOUT ITS WRITTEN CONSENT.	
USED ON		
APPLICATION		



**ALPHA  
TECHNOLOGIES**

TITLE  
*EXTERNAL INTERFACE CONNECTIONS*

ISSUED DATE	SIZE <b>A</b>	DRAWING NO. <i>496-9</i>	REV 
TOLERANCES	SCALE	SHEET <i>1</i>	CF <i>1</i>





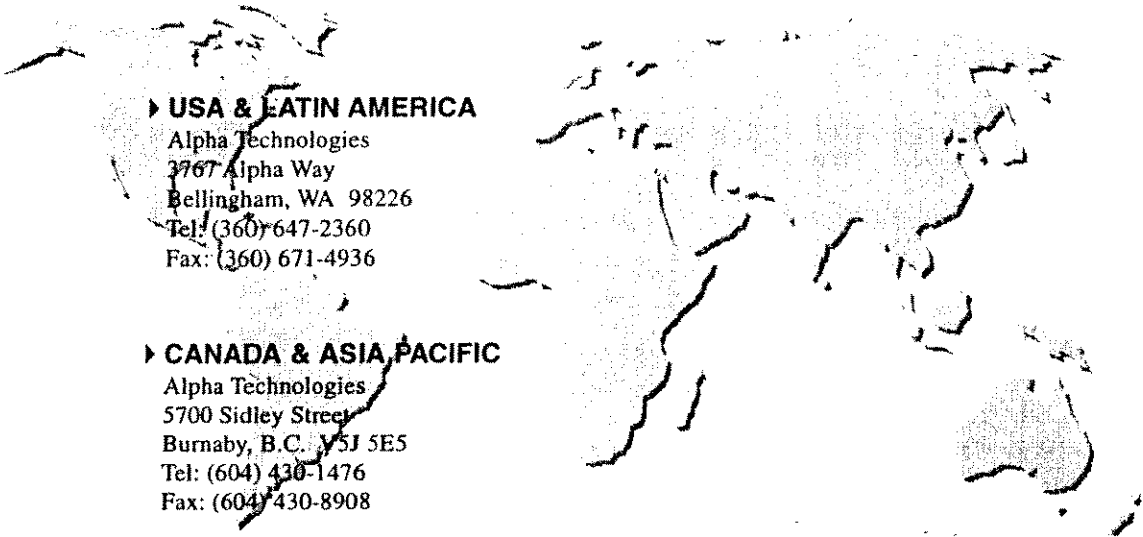

▶ **USA & LATIN AMERICA**

Alpha Technologies  
3767 Alpha Way  
Bellingham, WA 98226  
Tel: (360) 647-2360  
Fax: (360) 671-4936

▶ **CANADA & ASIA PACIFIC**

Alpha Technologies  
5700 Sidley Street  
Burnaby, B.C. V5J 5E5  
Tel: (604) 430-1476  
Fax: (604) 430-8908

▶ **UNITED KINGDOM**

Alpha Technologies  
Cartel Business Estate  
Edinburgh Way  
Harlow, Essex CM20 2DU  
Tel: +44-1279-422110  
Fax: +44-1279-423355

▶ **GERMANY**

Alpha Technologies  
Hansastrasse 8  
D-91126 Schwabach  
Tel: +49-9122-997303  
Fax: +49-9122-997321

▶ **ALPHATEC**

P.O. Box 6468  
3307 Limassol, Cyprus  
Tel: +357-5-375675  
Fax: +357-5-359595

▶ **AUSTRALIA**

Alpha Technologies  
8 Anella Ave., Unit 6  
Castle Hill, NSW 2154  
Tel: +612 894-7866  
Fax: +612 894-0234

<http://www.alpha-us.com>

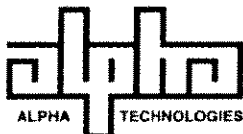

*Alpha sales and service offices located throughout the world*