

Configuring the network prior to installation is recommended to allow the transponder communication to be verified while the technician is on-site eliminating the need for a second visit if there are any problems.

Provision the RF MAC Address

The RF (modem) and CPE (Dual-IP) MAC Addresses are printed on barcode labels on the front and side of the DSM2 (Fig. 1), as well as on the packing slip.

- Provision the RF MAC Address with the proper DOCSIS® configuration file.
- If operating in Dual IP Mode, provision the CPE MAC Address so that it will be assigned a valid IP address on the public CPE network through the modem.



CAUTION!

For units in service, backup battery power will not be available during the following procedure.

Hardware Installation Procedure

1. Verify the power supply device address is correct.

Power supplies should be assigned a unique address, e.g., 1, 2, or 3 (do not use 0). No two power supplies monitored by a single DSM2 can have the same address. The address can be changed in the SETUP menu of the power supply's smart display (Fig. 2). See the power supply's technical manual for more information.

2. Install the DSM2.

- Turn off the XM2 battery breaker and disconnect all inverter module connections.
- Loosen the inverter module thumb screws and slide the inverter module out of the power supply just far enough to disconnect the ribbon cable. Disconnect the ribbon cable and remove the inverter module. If the inverter module is equipped with a communication module, remove it by loosening the two Phillips captive screws "A" (Fig. 3).
- Insert the 18-pin jumper into the Inverter Module (Fig. 4). **(For earlier versions, insert the longer pins into the inverter module).**
- Line up the 18-pin jumper with the DSM2 connector and connect the unit to the inverter module (Fig. 5).
- Tighten the two captive screws to secure the DSM2, re-install the inverter module, reconnect the ribbon cable, tighten thumb screws and inverter module connections.



CAUTION!

Verify the battery breaker remains in the OFF position.

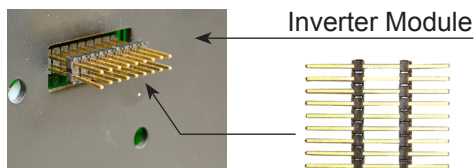

Fig. 4, 18-pin Jumper Installation Location

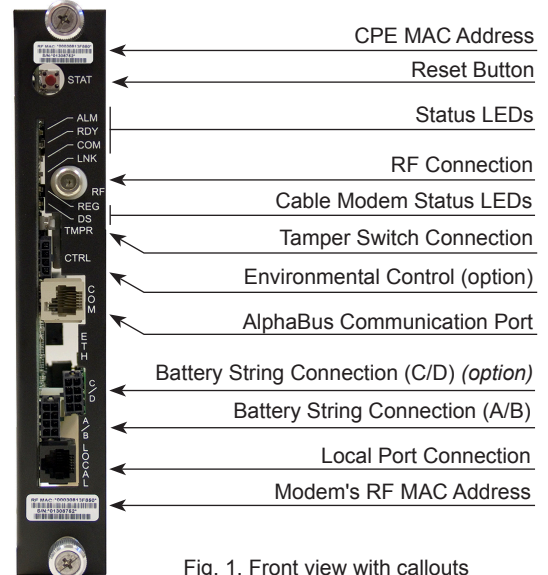

Fig. 1, Front view with callouts



Fig. 2, Smart Display

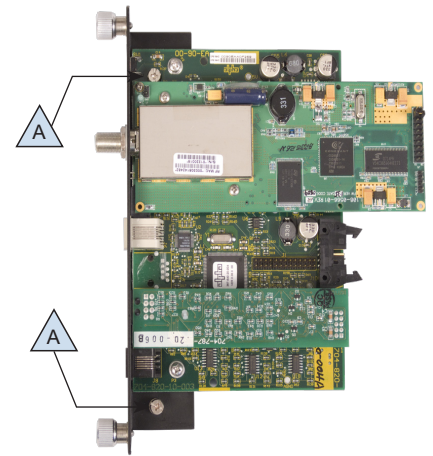

Fig. 3, Captive Screw location

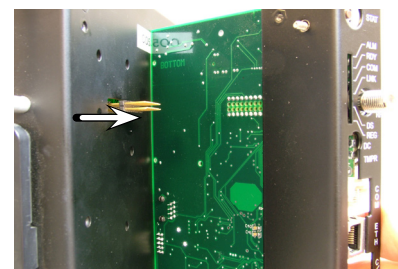

Fig. 5, Inverter Module, DSM2 connection

3. Make Battery Sense Wire Kit connections.

See the battery diagrams that came with the sense wire kit or reference the DSM2 Technical Manual.

4. Connect the RF drop and make front panel connections.

The DOCSIS specification for downstream power level is $\pm 15\text{dBmV}$. However, for optimal performance, set the level as close to 0 dBmV as possible.

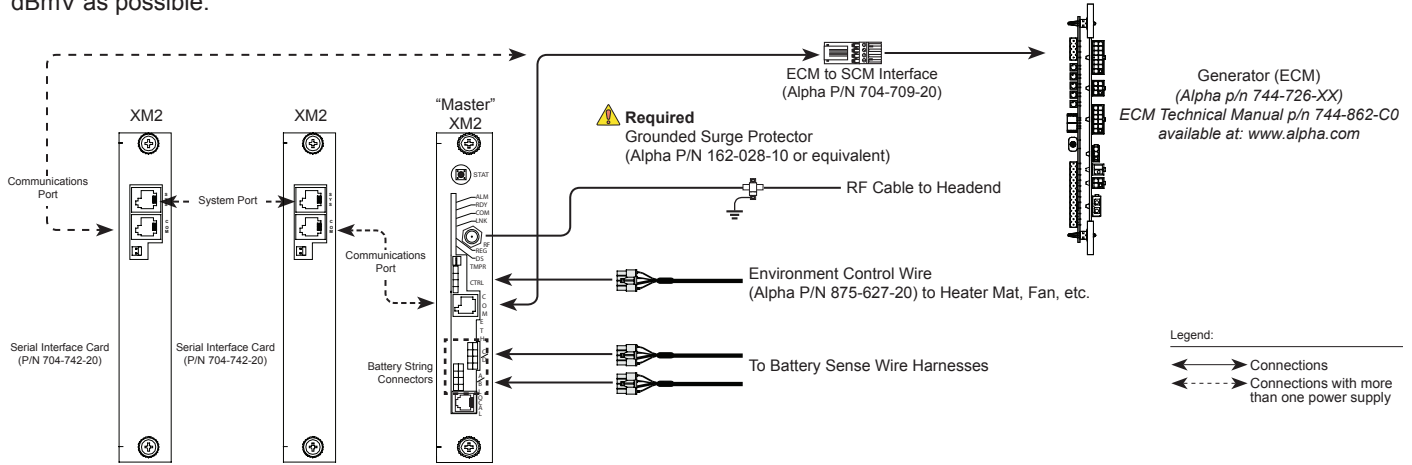

5. Initial Start-up and Test.

Plug the power supply into the AC outlet and turn on the battery breaker (XM2-HP units perform a 10-second self test to check the batteries).

The DSM2 LEDs blink three times and the RDY light begins blinking on and off.

Verify the DS and REG LEDs are on solid. This verifies that the DSM2 has registered an IP address on the public network.

Verify LNK LED is flashing in Single IP mode, or ON solid in Dual IP mode.

Verify no XM2 alarms are active.

6. Test the Connection.

With the DSM2 used in conjunction with the XM2-HP power supply, connectivity can be verified via the XM2-HP smart display. Otherwise, test the connection with a personal computer and a Local Port Adapter Cable (Alpha P/N 745-826-21). Terminal Emulation software is necessary (e.g., HyperTerminal). Serial communication settings are:

Baud: 19200; Data Bits, 1; Parity, None; Stop Bits, 1; Flow Control None

To test the connection, launch the terminal emulation software and press **ENTER**.

Type	SNAPSHOT, then press ENTER	Description
MAIN	> SNAPSHOT	
CM	MAC 000308142452	MAC address of the cable modem
CPE	MAC 0090EAA0F269	MAC address of the CPE Device
CM	192.168.1.204	IP address of the cable modem
CPE	192.168.1.205	IP address of the CPE device (dual IP mode only)
BATT	1A-2A 13.4 13.4	Power supply battery voltages
BATT	3A-4A 13.7 --	Power supply battery voltages
CM	TX (dBmV) 47.2	Cable modem transmit level
CM	RX (dBmV) 8.5	Cable modem receive level
CM	Ver 1.38	Cable modem firmware version
DSM	VERV 2.02.1	Transponder processor firmware version
MAIN	>	



NOTE:

The procedure shown at left will allow you to see MAC addresses, useful in working with network registration. IP addresses can help determine if the transponder is recognized by the management system, and if the transponder is in single or dual IP operation (in dual IP, the CPE and CM will have an IP address; in single, only the CM will have an IP address). Correct battery voltages verify that the battery sense cable is connected properly. Cable modem transmit and receive levels will be helpful in verifying proper padding at the RF drop.

For contact information visit www.alpha.com

The Alpha Group >

North America	Europe, Middle East & Africa			Asia Pacific	Latin & South America
USA Tel: +1 360 647 2360 Fax: +1 360 671 4936	Cyprus Tel: +357 25 375 675 Fax: +357 52 359 595	Germany Tel: +49 9122 79889 0 Fax: +49 9122 79889 21	Lithuania Tel: +370 5 210 5291 Fax: +370 5 210 5292	P.R. China Tel: +852 2736 8663 Fax: +852 2199 7988	Contact USA office
Canada Tel: +1 604 430 1476 Fax: +1 604 430 8908	Russia Tel: +7 495 925 9844 Fax: +7 495 916 1349	United Kingdom Tel: +44 1279 501110 Fax: +44 1279 659870			