



Installation and Quick Start Guide

The AlphaNet DSM3 Series (DSM3, DSM3x models) Embedded DOCSIS Transponder allows monitoring of Alpha power supplies through existing cable network infrastructure. Advanced networking services provide quick reporting and access to critical powering information.

DSM3 Series transponders utilize Simple Network Management Protocol (SNMP) and standard Management Information Bases (MIBs) to provide network status monitoring and diagnostics. A Web interface enables authorized personnel direct local and remote access to advanced diagnostics using a common Web browser. No custom software or proprietary cables are required.

The transponders can be installed and configured for operation in either the XM2 or XM2-HP Power Supply. The major features of the DSM3x are shown below; the DSM3 is shown on the following page.

DSM3x DOCSIS Transponder

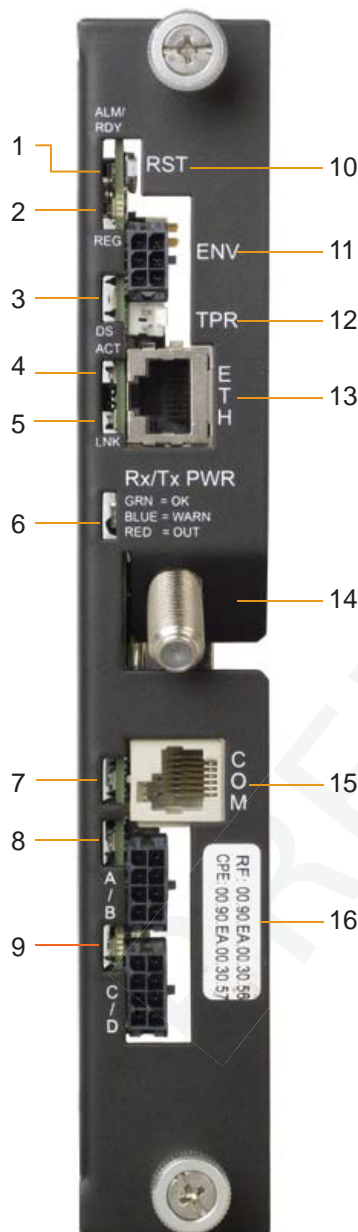

Item	LED or Connector	Status	Behavior	Indication
1	ALM/RDY: Alarm and Ready	N/A	OFF	No power or malfunctioning transponder
		GRN	ON	Transponder reset in process
			Steady Blinking	Normal operation
	RED	Blinking more OFF than ON	Minor Alarm	
		Blinking more ON than OFF	Major Alarm	
2	REG: Upstream ranging and registration lock.	GRN	OFF	No power, upstream frequency undetermined
			BLINKING	Power on, downstream locked, upstream frequency ranging, DHCP request pending
			ON	CMTS registration completed
3	DS: Downstream RF Carrier detection and lock.	GRN	OFF	No power / downstream carrier
			BLINKING	Power on, downstream carrier frequency searching
			ON	Downstream carrier lock
4	ACT: CPE Activity status	GRN	OFF	No Ethernet communications activity
			BLINKING	Momentary flash while CPE communications are ongoing via the Ethernet craft port.
5	LNK: CPE Link status	GRN	OFF	No link
			ON	Link on Ethernet Craft port
6	RF Rx/Tx Power Level Indicator	TRI	OFF	No RF detected
			Blue	Rx/Tx RF Level within the warning range
			Green	Rx/Tx RF level within tolerance
7	COM: Alpha Bus communications.	GRN	OFF	No Alpha Bus Communications
			BLINKING	Momentary flash - Alpha Bus Port communications active
8	BAT A/B	GRN	ON/OFF	ON (steady) if battery string(s) connected correctly.
9	BAT C/D [DSM3x only]	GRN	ON/OFF	ON (steady) if battery string(s) connected correctly.
10	RST: Reset button			
11	ENV: Environmental / LAP Control connector			
12	TPR: Tamper Switch connector			
13	ETH: Ethernet connection			
14	RF Connection			
15	COM: AlphaBus Communications connector			
16	RF, CPE MAC Address label			

Fig. 1, DSM3X Transponder Front panel Indicators and Connectors

DSM3 DOCSIS Transponder

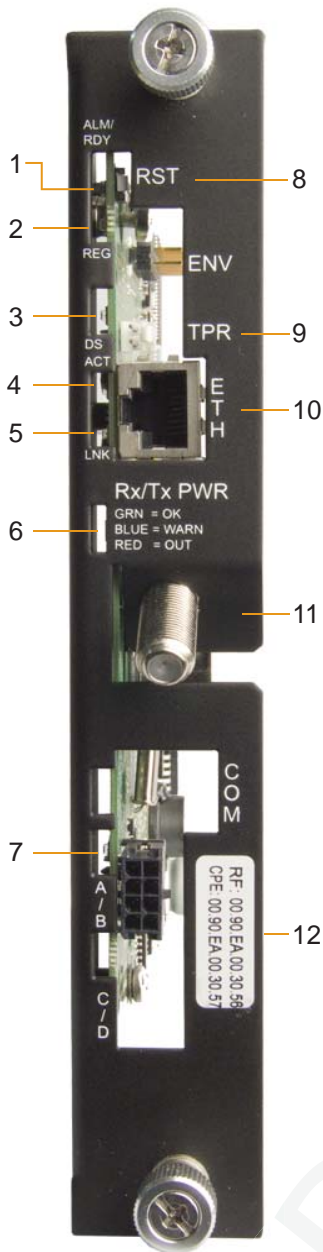

Item	LED or Connector	Status	Behavior	Indication
1	ALM/RDY: Alarm and Ready	N/A	OFF	No power or malfunctioning transponder
		GRN	ON	Transponder reset in process
			Steady Blinking	Normal operation
			RED	Blinking more OFF than ON
			Blinking more ON than OFF	Major Alarm
2	REG: Upstream ranging and registration lock.	GRN	OFF	No power, upstream frequency undetermined
			BLINKING	Power on, downstream locked, upstream frequency ranging, DHCP request pending
			ON	CMTS registration completed
3	DS: Downstream RF Carrier detection and lock.	GRN	OFF	No power / downstream carrier
			BLINKING	Power on, downstream carrier frequency searching
			ON	Downstream carrier lock
4	ACT: CPE Activity status	GRN	OFF	No Ethernet communications activity
			BLINKING	Momentary flash while CPE communications are ongoing via the Ethernet craft port.
5	LNK: CPE Link status	GRN	OFF	No link
			ON	Link on Ethernet Craft port
6	RF Rx/Tx Power Level Indicator	TRI	OFF	No RF detected
			Blue	Rx/Tx RF Level within the warning range
			Green	Rx/Tx RF level within tolerance
			Red	Rx/Tx RF level outside the warning range
7	BAT A/B	GRN	ON/OFF	ON (steady) if battery string(s) connected correctly.
8	RST: Reset button			
9	TPR: Tamper Switch connector			
10	ETH: Ethernet connection			
11	RF Connection			
12	RF, CPE MAC Address label			

Fig. 2, DSM3 Transponder Front panel Indicators and Connectors

Overview



CAUTION!

For units in service, backup battery power will not be available during this procedure.

DSM3 Series installation and setup is comprised of three basic steps:

1. **Installation** of the DSM3 Series into the power supply, connecting the RF Cable, battery sense wire harnesses, Environmental (DSM3x only), Tamper switch, Ethernet, and verifying operation.
2. **Setting Options:** the DSM3 Series is designed for out-of-the-box, "plug and play" operation. Non-default settings such as SNMP trap destination addresses may be required for the Network Management System (NMS). SNMP trap addresses can be set automatically via the DOCSIS configuration file's docsDevNmAccessTable per RFC 4639, while DSM Series proprietary options may be set through type 11 TLV entries. The SCTE-HMS and Alpha MIBs may need to be compiled into a MIB browser before it can be used to monitor or set transponder and power supply parameters. *Refer to the DSM3 Series Technical Manual for details.*
3. **Configuring the Network:** provisioning the DHCP Server with the transponder's MAC Address and assigning it a DOCSIS configuration file.

These steps can be performed independently of one another. However, configuring the network prior to field installation will allow the installation to be verified while personnel are still on-site. Performing field installation before network configuration might result in additional field service calls to correct mistakes.

Installation Procedure

Removing the Inverter Module:

1. Turn off the battery breaker.



CAUTION!

Service personnel must verify the Inverter Module battery breaker remains in the OFF position until instructed to return unit to service.

2. Disconnect the battery input and temp probe cables from the Inverter Module and the TMPR and XPDR cables from the communication module if one is currently installed.
3. Loosen the three thumbscrews.
4. Grasp the handle on the right side of the Inverter Module. Pull firmly to release the module from the inverter connector. Gently slide the module assembly straight out until the Inverter Module ribbon cable connector is accessible. Open the retaining clips to remove the the ribbon cable (*see Fig.3 below*).

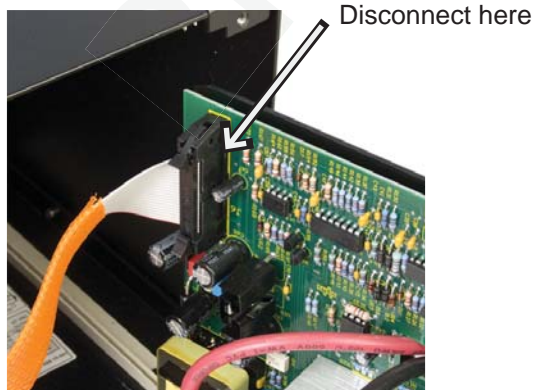

Fig. 3, Inverter Module Ribbon Cable



Fig. 4, DSM3 Series Transponder and Inverter Module

Installation Procedure, continued

5. If the Inverter Module is already equipped with a Communication Module, remove it by loosening the two Phillips captive screws (Fig. 5, item A).

The following steps apply to both new installations or removal/replacement of existing transponders:

6. Connect the 18-pin jumper (Fig. 6) supplied with the transponder into the header on the back of the DSM3 Series circuit board (Fig. 7).



CAUTION!

Use of the incorrect jumper will cause damage to the Transponder. Fig. 6 shows the correct 18-pin jumper.

7. Line up the 18-pin jumper with the header on the Inverter Module and connect the unit to the Inverter Module (Fig. 8).
8. Fasten the Transponder to the Inverter Module by tightening the two captive screws. It is recommended the screws be tightened alternately, a few turns at a time so the transponder aligns in parallel to the Inverter Module.



Fig. 6, 18-pin jumper
(Alpha p/n 540-286-19)

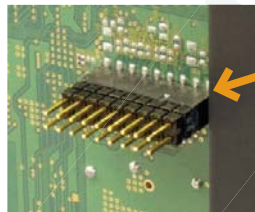

Fig. 7, Connecting the Jumper



Fig. 8, Connecting the
Communications Module to
the Inverter Module

9. Reinstall the Inverter Module and reconnect the ribbon cable (see Fig. 9). Make front panel connections (tamper, temperature sensor, battery sense, etc.).
10. Verify the recording of the cable modem MAC address (RF MAC) from the front of the unit, and the reporting of the MAC address to the network manager for network provisioning.



Fig. 9, Inverter Module / Ribbon Cable Connection

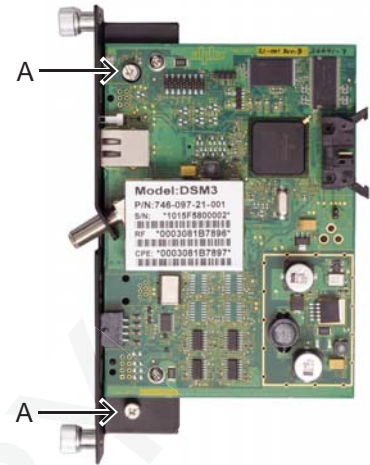

Fig. 5, Captive Screw Locations

Installation Procedure, continued

11. Make Battery Sense Wire Kit connections. See the battery diagrams that came with the sense wire kit or reference the DSM3 Series Technical Manual (*Alpha p/n 745-814-B8*).
12. Connect the RF drop and make front panel connections as shown in Fig. 10 for the DSM3, or Fig. 11 for the DSM3x. The DOCSIS specification for downstream power level is ± 15 dBmV. However, for optimal performance, set the level as close to 0 dBmV as possible.

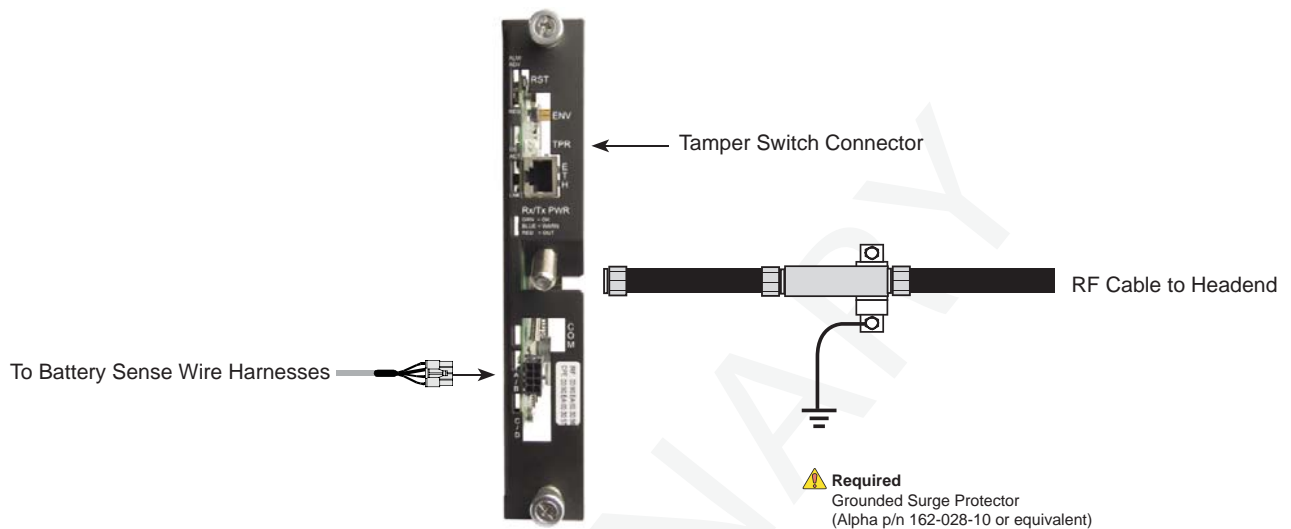

Fig. 10, DSM3 Wiring Diagram

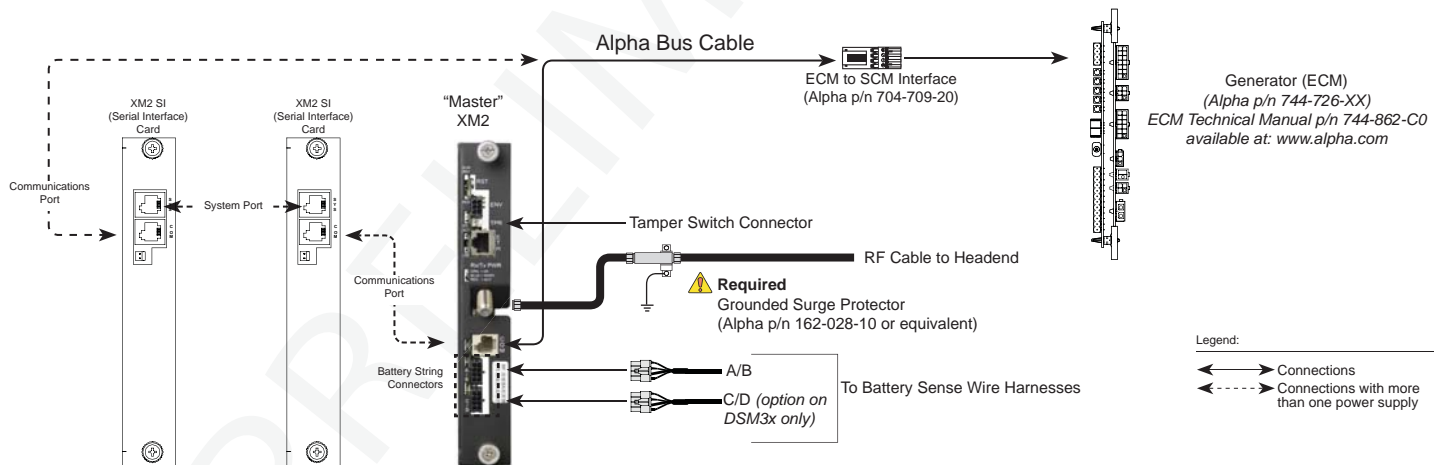

Fig. 11, DSM3x Wiring Diagram



NOTE:

Each power supply must have a unique address. Refer to Intelligent CableUPS technical manual (p/n 017-805-B0), or the DSM3 Series Transponder technical manual (p/n 745-814-B8) for additional information.

Initial Turn-up and Test / Returning the unit to Service

1. Plug the power supply into the AC outlet / turn on the battery breaker.
2. The DSM Series 3 Status LEDs will all blink in unison upon initial power up. The RDY LED will then begin blinking steadily indicating normal processor activity.
3. Verify the DS and REG LEDs are on solid. This verifies the Communications Module has registered an IP address on the network.
4. Verify the RF LED is solid Green, indicating Upstream and Downstream Power is within the default specified range and the Upstream RF Power is below the recommended +50 dBmV.
5. Verify no XM2 / XM2-HP alarms are active.

RF Power Default Values		
LED Color	Rx Range (dBmV)	Tx Range dBmV)
Green	+10 to -10	0 to +50
Blue	+15 to +10 and -10 to -15	+50 to +55
Red	>+15 and >-15	>+55

Table 1, RF Power Default Values

Test Connection

With the DSM3 Series Transponder used in conjunction with the CableUPS, connectivity may be verified via the smart display. You may also test the connection using a computer and a standard Ethernet cable. Connect the computer to the Ethernet port on the transponder, launch an Internet browser (e.g. Internet Explorer) and enter 192.168.100.1 in the address field. The General Configuration page shown below will appear and display connectivity, power levels and power supply status information. System Name, System Location, System Contact and Common Logical ID may be edited on this page; when prompted for a User Name and Password, use "Alpha" and "AlphaGet".

AlphaNet™ DOCSIS Status Monitor
General Configuration

General HMS Alarms Advanced Settings Print

Communications

Configuration	2IP US		
SysUpTime	7 days 11h:13m:17s		
Firmware Version	4.4.6.0_02.00_NA		
CM	CPE Transponder		
MAC Address	00:90:EA:00:30:84	00:90:EA:00:30:85	
IP Address	192.168.1.124	192.168.1.120	
CM Tx (dBmV)	42.0	41.0	
CM Rx (dBmV)	3.2	32	
SMR (RxMER)	44.2		
System Name	Alpha	SET	
System Location	Bellingham		
System Contact	John Doe		
Common Logical ID	DSM3		

Power Supplies

Model	ALPHA / XM2						
Firmware	7.03.0						
Major Alarm	OK						
Minor Alarm	OK						
Inverter Status	OFF						
Tamper	Closed						
Self Test	Start Test						
Time Since Last Standby							
Last Standby Duration							
Total String Voltage (V)	41.60						
Temperature 1 (°C)	15						
Input Voltage (V)	124.80						
Output Voltage (V)	89.00						
Output Current 1 (A)	1.00						
Status	Actstate	Mode	Temperature	Hysteresis	Timer	Countdown	
Environmental Controller	Contact Open	Closed	Heater	24	2	1	0
LAP	Not Installed	Not Installed					

Batteries

	Battery 1 (V)	Battery 2 (V)	Battery 3 (V)
String 1	13.90	13.95	14.00
String 2	13.95	14.00	13.90

copyright © 2010, AlphaTechnologies Inc., All Rights Reserved

Fig. 12, General Page
(sample data values shown for illustration purposes only)

For more information visit www.alpha.com

United States Bellingham, Washington Tel: 360 647 2360 Fax: 360 671 4936
Canada Burnaby, British Columbia Tel: 604 436 5900 Fax: 604 436 1233