

Power

Battery Heater Mats

Extends Battery Runtime in Cold Weather



- New design consumes 30% less power
- Durable polyester construction and insulated design
- Sealed on-mat electronics for maximum protection
- On-mat thermal switch and thermal fuse for redundant safety
- Piggyback plug standard on 120V models

Alpha's battery heater mats are designed with safety and efficiency in mind. Alpha's battery heater mats are a low-cost way of keeping backup batteries operating at their optimal temperature, maintaining battery backup performance at >70% of nominal levels at temperatures below 32°F/0°C. The heater mats' insulated bottoms ensure that energy is directed to the batteries and not wasted heating the enclosure. Their durable polyester outer shells protect the heating elements from damage; their redundant thermal control protection ensures against overheating; and their fused power input protects against shorts. Alpha battery heater mats are a smart addition to any backup power system.

Battery Heater Mats

VRLA Battery Efficiency VS Temperature and Discharge Rate

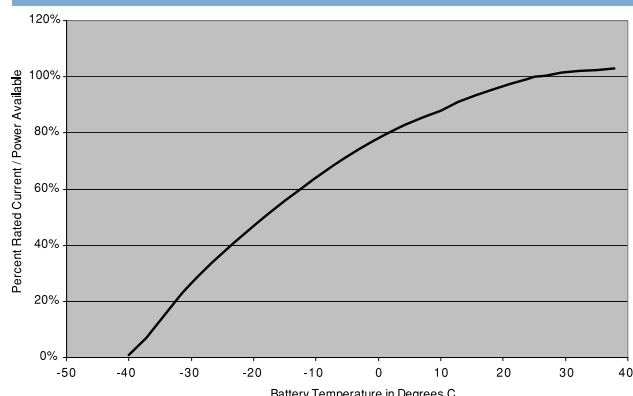

Battery performance is set for a normal room ambient temperature of 25°C/77°F. In outdoor installations, as temperatures drop the batteries lose the ability to perform the chemical reactions necessary to provide backup. For example, a battery string that provides 2 hours backup at room temperatures will only provide 1 hr 36 min (80%) backup at 0°C/32°F. As temperatures approach -40°C the chemical reaction virtually ceases and no backup can be expected. Battery heater mats are low-wattage heating pads designed to keep the core battery temperature at a level that will maintain at least 70% capacity at -30°C. Battery heater mats maintain battery backup performance in areas where lower temperatures are common.

Stand Alone Heater Mats

Model:	BHM-1X3-120/BHM-1X3-240	BHM-2X2-120/BHM-2X2-240	BHM-1X6-120/BHM-1X6-240	BHM-PN48-120/BHM-PN48-240
Part Number:	189-062-10/189-062-11	189-031-10/189-031-10	189-072-10/189-072-11	189-029-10/189-029-11
Length (in/mm):	21.00/533	27/686	27.75/705	21/534
Width (in/mm):	13.00/330	13.5/343	15.75/400	20.75/527
Wattage:	140	180	215	198
Heating Density:	0.50W/in ²	0.50W/in ²	0.50W/in ²	0.50W/in ²
Battery Type:	Case 27/31	Case 27/31	15.5" Front Terminal	Case 27/31
Batteries/Mat:	3	4	6	4
Enclosure:	PME, PWE-3, PWE-6, PWE-9, UPE-3, UPE-6, PN-3, PN-4, UPE-M3/M6, BE-PME, BE-PWE	PWE-4, PWE-8, UPE-4, UPE-8, UPE-M8	PWE-6FT	PN-4, PN-3

All Mats

Line Cord Thermostat

Turn on Temp:	5 deg C
Turn off Temp:	15 deg C

Mat Mounted Thermostat

Over Temp Off:	50 deg C
Turn Back on:	40 deg C
Thermal Fuse Rating:	85 deg C

Optional Line Cord Thermostat

Turn on Temp:	0 deg C
Turn off Temp:	10 deg C

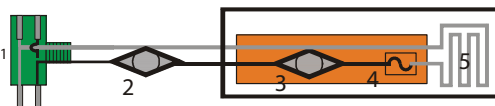

The main power connector (1) on the heater mat is plugged into an AC source. In low temperature conditions the main control thermistor (2) will allow power to flow to the heater mat coil (5). The thermistor is mounted on the power cord so that it reacts to the enclosure temperatures and not the mat surface temperature. A secondary thermistor (3) is mounted on the mat with significantly higher temperature settings than the main thermistor (2). This thermistor keeps the mat from overheating during extended run periods. A thermal fuse (4) is a final fail safe device. The power connector (1) has an AC receptacle so that additional mats can be plugged in. Its parallel wiring keeps the failure of the first mat from affecting the operation of others in the string.

Battery Heater Mat Layouts

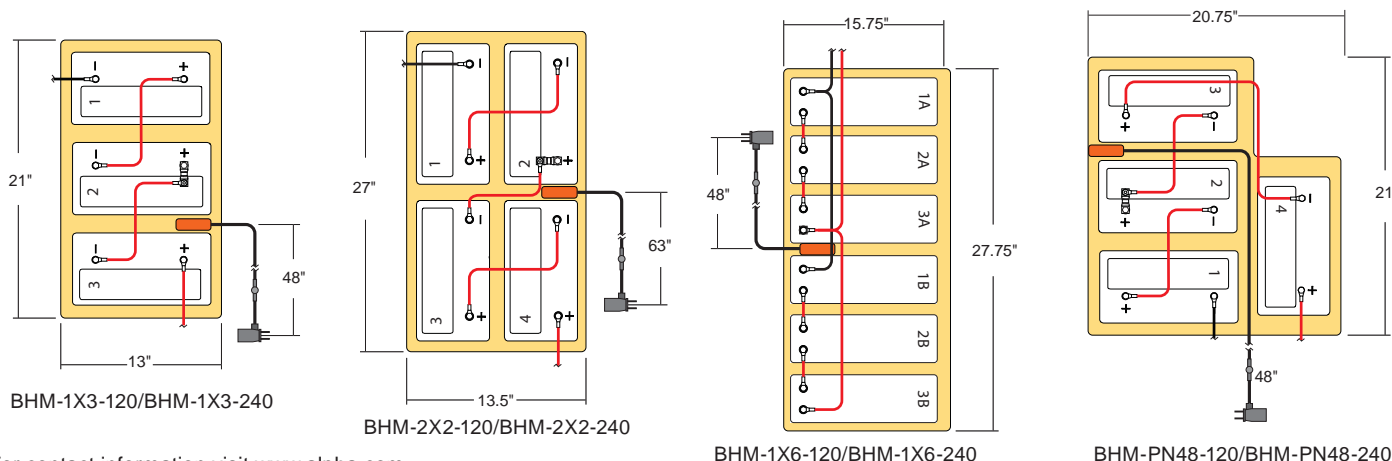

For contact information visit www.alpha.com

The Alpha Group >

Europe, Middle East & Africa			Asia Pacific	North America	Latin & South America
Cyprus Tel: +357 25 375 675 Fax: +357 25 359 595	Germany Tel: +49 9122 79889 0 Fax: +49 9122 79889 21	Lithuania Tel: +350 5 210 5291 Fax: +350 5 210 5292	P.R. China Tel: +852 2736 8663 Fax: +852 2199 7988	Canada Tel: +1 604 430 1476 Fax: +1 604 430 8908	Contact USA office
Russia Tel: +7 495 925 9844 Fax: +7 495 916 1349	United Kingdom Tel: +44 1279 501110 Fax: +44 1279 659870			USA Tel: +1 360 647 2360 Fax: +1 360 671 4936	