



White Paper

Broadband Powering
Methods: A natural
engineering choice

Broadband Powering Methods: A natural engineering choice

John Sams of Alpha Technologies examines the reason for a move up from 60V line power supplies in the future.



Although current European safety regulations preclude the use of 90V line power supplies, this article examines the reasons for considering a move up from 60V in terms of efficiency, and describes possible design considerations.

The process of competitive selection in broadband powering techniques has produced a keen emphasis on power supply cost, efficiency and reliability. Product differentiation is strategically important in the power conditioning industry, and relies on the manipulation of key performance parameters that directly affect either the equipment capital or ownership costs. Capital costs extend directly from the quantity and type of components used. Reducing power processing component counts reduces cost, and typically increases reliability.

Repair

Ownership costs include repair and replacement of components and the cost of the electricity used by the power conditioner and its loads. These costs are inversely related to reliability and the unit's efficiency in powering the desired loads. Thus, a technique that optimally reduces component counts and increases efficiency should be the natural power technology of choice.

This article looks at efficiency and then compares several technologies for specific capital cost, reliability and efficiency performances.

A power conversion device's influence on the cost of electricity to power the desired loads is related to the following six key factors:

1. INPUT POWER QUALITY

The quality of the power drawn by the power conditioner is quantified by the measure of its input power factor. This is commonly defined as the ratio of the real power consumed to the apparent power (VA) measured at the input terminals of the device. The customer (the system operator in this case) only pays the utility for the real power consumed at the watt-meter, even though the host utility has to generate the transmission losses associated with the apparent power (VA). Thus, it is in the interest of the utility that these two values are as equal as possible: a power factor of one.

Restrictions

To this end, the US domestic electric power industry and regulatory bodies are planning restrictions or penalties on loads that present a low power factor or high harmonic current content. Such measures have already been legislated in the European Union and are commonly written into service agreements by some domestic utilities. Therefore, in the long term, a power conditioner should present a power factor to the utility greater than 0.90 and an input current total harmonic distortion (THD) of less than 10 per cent, for the best terms in negotiating an electric service rate schedule.

The start-up inrush current required by a conditioner design can also become a problem for the system operator. Conditioner designs based upon a single stage transformer can draw up to 10 times their rated

input current due to saturation in the transformer core while operation stabilizes. Capacitive input conditioner designs can draw similar or greater amounts of current during start-up due to the charging of large input rectifier capacitors. To the operator this can translate to nuisance circuit breaker trips and related truck roles.

2. CONVERSION EFFICIENCY

The raw power conversion efficiency of a power conditioner is simply defined as the output power delivered to the conditioner's output terminals divided by the input power delivered to the input terminals. For cable television and broadband systems, the power conversion process is defined as the conditioning of a utility sine wave of standard voltage to a wave form and voltage best suited for the coax plant, commonly a 60 or 90 Volt trapezoidal wave form. Two principal methods exist for performing this process and are known as single conversion and double conversion.

2.1 Single conversion design

Single conversion designs connect the plant load to the utility through a single stage of power conditioning, typically a ferroresonant transformer as illustrated below in Figure 1.

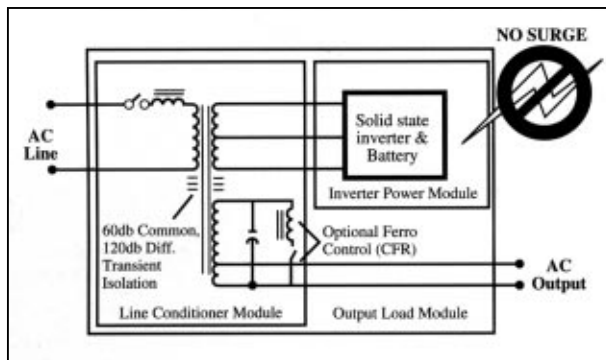

In the event standby power is required during an outage, an artificial utility is created through a battery string and coupled to the transformer via a switching inverter. The inverter commutates the battery across the transformer at the utility line frequency. Thus the inverter is only used during utility outages. The maximum efficiency of such a unit typically 90 per cent at full load.

Conversion efficiency over the load range of 25 to 85 per cent of rated full load is typically 75 to 89 per cent. It is recommended that the power supply installation be operated at approximately 85 per cent of full load to approach maximum efficiency and provide reserve capacity for plant start-up and peak load fluctuations.

An alternative single conversion design, based upon controlled ferroresonance (CFR), improves efficiency vs loading performance, output voltage regulation and transient load response, input frequency tolerance and input power factor. CFR is created by adding a voltage controlled inductance across the ferro's tank circuit capacitor. Implementing output voltage control in this manner eliminates the need to operate the transformer in saturation to achieve regulation, increasing efficiency particularly under higher load conditions. The maximum efficiency of such a unit is typically 94 per cent at full load.

Superior characteristics

Conversion efficiency over the load range of 25 to 85 per cent of rated full load is typically 82 to 93 per cent. This is performed without sacrificing the superior characteristics of ferroresonant technology. Thus, a minor increase in complexity (cost), provides a wider dynamic range for cost efficient operation. The trapezoidal output wave form of ferro-based designs typically produces a plant power factor of 0.85 to 0.92. The actual value is related to power supply loading and the coax loop resistance of the powered plant segment. As loading or the loop resistance increases, power factor will also increase.

2.2 Double conversion design

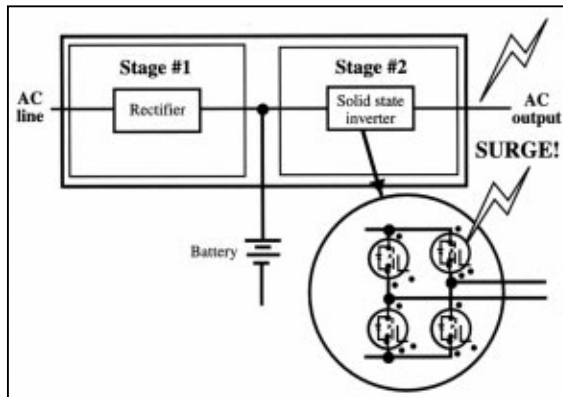

Figure 2: Double conversion

Double conversion requires the addition of a second power processing stage to isolate completely the load from the utility line. This is implemented by placing a battery string between an input rectifier and an output inverter, as illustrated in Figure 2.

The power conditioner output is now independent of the utility line condition.

However, an efficiency penalty is incurred as each stage typically operates at 91 per cent efficiency at 100 per cent of rated full load, the combined efficiency is then 83 per cent. Conversion efficiency over the load range of 25 to 85 per cent of rated full load is typically 69 to 82 per cent.

Additionally, the double conversion implementation requires twice as many electronic components as compared to the single conversion approach. This is due to the addition of the rectifier. Another contrast is that the principal output stage (electronic inverter) must be connected directly to the outdoor plant and must operate continuously, increasing fatigue and vulnerability to surge and lightning.

Tailored

Double conversion power conditioners also produce a trapezoidal wave form similar to the single conversion designs. However, the crest factor of the wave form can be more closely tailored to an ideal wave form, particularly at lower load levels. Thus power factors of 0.92 to 0.94 can be achieved.

3. PLANT SIDE POWER FACTOR COSTS

Power factor (PF) is a dimensionless unit that is a measure of the ratio between the real and apparent power consumed by an electric load. In a classic sense, the power actually used by a device is defined as "real" or resistive, the result is heat, RF, light or whatever is desired as output from an electrical device. Commonly, a device will also present a reactive (inductive or capacitive) load along with its resistive load.

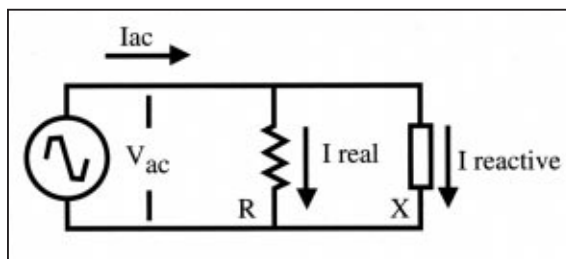

Figure 3: Resistive and reactive loads

Thus, the vector magnitude of a complex quantity ($P_{resistive} + i P_{reactive}$) is defined as the "apparent" power flow. Note that a vector magnitude is defined as the square root of the quantity of the resistive component squared plus the reactive component squared ($\sqrt{P_{resistive}^2 + P_{reactive}^2}$). The relationship is illustrated in Figure 3.

Using the following variable conventions and identities:

$$S = \text{Apparent Power} = I_{ac} * V_{ac} \quad (1)$$

$$Q = \text{Reactive Power} = V_{ac} * I_{reactive} \quad (2)$$

$$P = \text{Real Power} = V_{ac} * I_{real} \quad (3)$$

Note: Vector quantities printed in bold upper case.

By Simple circuit analysis:

$$S = P + iQ \quad (4)$$

$$VA = |S| \quad (5)$$

The magnitude of apparent power is most commonly expressed as VA, the simple product of the voltage and current measured at the input of a circuit. Power factor then is the efficacy of a load to utilize the input VA:

$$\text{Power Factor (PF)} = P/VA \quad (6)$$

Through similar Ohm's law substitutions, this relationship can be extended directly to the circuit current:

$$\text{Power Factor} = I_{\text{real}} / |I_{\text{apparent}}| \quad (7)$$

It can also be expressed as the cosine of the displacement phase angle, θ , between the voltage VAC and Current IAC:

$$\text{Power Factor} = \text{Cos}(\theta) \quad (8)$$

Referring to Figure 3, the frequency of the power source directly affects the reactive component of the load. For modern coax powered loads this component is capacitive, thus the reactive load drops to zero when the circuit is operated at DC, and the power factor increases to 1.0. Thus, all power sent into the coax is used to its fullest potential in transporting the energy to the loads and to perform the work desired.

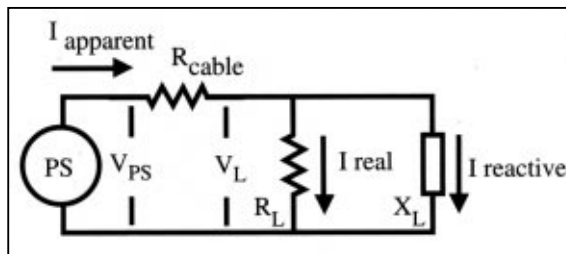

Figure 4: Effect of cable loop resistance

The circuit in Figure 3 combines the loop resistance of the coax with the electronic load of the amplifiers and other devices. To establish the effect of power factor on the efficiency of the coax to deliver power to the desired load, Figure 4 breaks the loop resistance, R_{cable} out of the load.

By observation, I_{real} should decline as R_{cable} increases, (i.e. moving the load further down the coax). However, most modern coax powered devices use a switch mode AC to DC power pack that pre-

sents a constant load to the network. Thus as R_{cable} increases, P_{real} and P_{reactive} of equation 3 remain constant, and I_{real} and I_{reactive} increase proportionally. The total power lost in the coax is:

$$P_{\text{cable (VA)}} = |I_{\text{apparent}}|^2 * R_{\text{cable}} \quad (9)$$

Power loss, associated with transmitting just the real component of the load is:

$$P_{\text{cable (real)}} = I_{\text{real}}^2 * R_{\text{cable}} \quad (10)$$

The coax transmission efficiency, θ_{cable} is

$$\theta_{\text{cable}} = P_{\text{cable (real)}} / P_{\text{cable (VA)}} = (I_{\text{real}}^2 * R_{\text{cable}}) / (|I_{\text{apparent}}|^2 * R_{\text{cable}}) = I_{\text{real}}^2 / |I_{\text{apparent}}|^2 \quad (11)$$

Substituting for I real from equation (7). equation (11) reduces to:

$$O_{cable} = PF^2 \tag{12}$$

Thus, the overall delivery of power to the plant loads, P plant, is equal to input VA times the coax transmission efficiency:

$$P_{plant} = O_{cable} * VA_{input} \tag{13}$$

Substituting equation (6) and (12) into (13) yields:

$$P_{plant} = PF^2 * (P_{input} / PF) \tag{14}$$

Reducing:

$$P_{plant} = PF^2 * P_{input} \tag{15}$$

Ultimately, P plant resolves to the power required for the plant's AC to DC power packs and the unavoidable (real component) coax transmission losses.

3.1 Single conversion power supply example

Figure 5 on illustrates a single conversion 90 Volt power supply with a measured output of 12.4 Amps and a power factor of 0.91 (a common condition).

Using (6), the input power to the coax is:

$$P_{input} = 90 * 12.2 * 0.91 = 1,000 \text{ Watts}$$

Using (15), power consumed by the electronic devices is:

$$P_{load} = 1,000 * 0.91 = 910 \text{ Watts}$$

Coax transmission line losses associated with the AC powered load are the difference between input and output power levels:

$$P_{loss-ac} = 1,000 - 910 = 90 \text{ Watts}$$

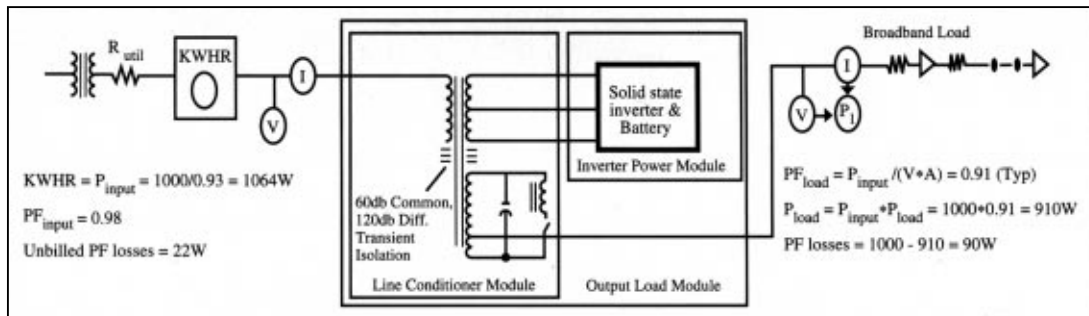

Figure 5: Single conversion 90 volt power supply

The power conditioner efficiency is 94 per cent, thus the input power is 1,064 Watts which is the power consumption rate measured by the kilowatt-hour meter. Thus, if the electric service rate is 0.10\$/KWHr, the bill to the operator will be \$932 per year. In the same fashion that the operator pays for the power factor related losses in the plant the utility must pay for similar distribution losses. The CFR's input power factor of 0.98 results in a 22 Watt loss to the utility. The harmonic distortion of the input current is also low, less than 5 per cent.

3.2 Double conversion power supply example

Figure 6 illustrates a double conversion 90 Volt power supply with a measured output of 11.8 Amps and a power factor of 0.94.

Using (6), the input power to the coax is:

$$P_{\text{input}} = 90 * 11.8 * 0.94 = 1,000 \text{ Watts}$$

Using (15), power delivered to the electronic devices is higher than the single conversion design:

$$P_{\text{load}} = 1,000 * 0.94 = 940 \text{ Watts}$$

Coax transmission line losses associated with the AC powered load are the difference between input and output power levels:

$$P_{\text{loss-ac}} = 1,000 - 940 = 60$$

The power conditioner efficiency is 83 per cent, thus the input power is 1205 Watts which is the power consumption rate measure by the kilowatt-hour meter. Again, if the electric service rate is 0.10\$/KWHr, the bill to the operator will be \$1056/year.

In the same fashion that the operator pays for the power factor related losses in the plant, the utility must pay for similar distribution losses. This loss is 516 Watts for a rectifier input power factor if 0.70. Additionally, harmonic distortion of the input current is also significant Even low cost power factor correction circuits will not remove this distortion, which can reach 30 per cent or more. Harmonic current flow is just as damaging to the utility as the power factor. It becomes apparent why the utility becomes concerned about low power factor loads, their profits are diminished by having to supply the reactive component of their customers' load. Commonly reactive power sources must be installed by the utility to control the effects of these conditions.

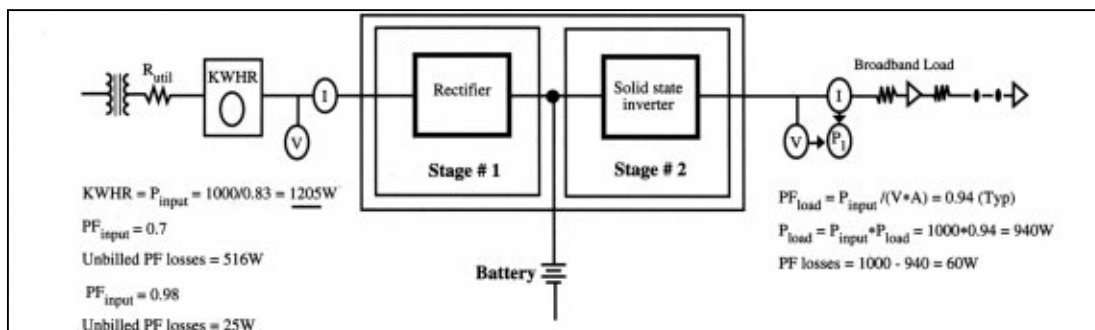

Figure 6: Double conversion 90 volt power supply

Energy

Comparing the result of these two examples it is apparent that, because of its higher power factor, a double conversion design can deliver more useful energy to the plant per unit of output power. A double conversion design delivering 1,000 Watts into the plant can produce 940 Watts of useful power, where the single CFR transformer design delivered 910 Watts. The output power of the CFR unit would have to be increased to 1,033 Watts (940/.91) to deliver an equal amount of energy to the load. This translates to a billed input power of 1,111 Watts (1,033/.9), \$943 per year.

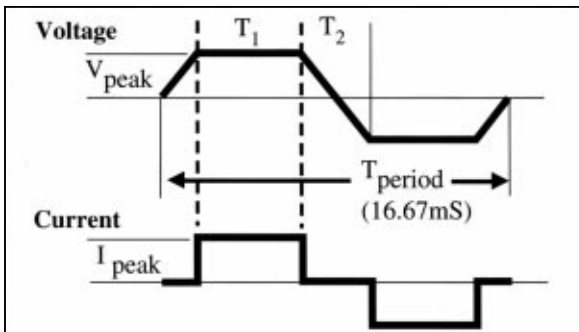

Figure 7: Trapezoidal powering waveforms

However, due to the double conversion design's low efficiency it still requires 94 additional Watts (1,205-1,111), or \$82 per year more to operate. A standard ferro transformer unit under the same conditions, will require 1,150 Watts from the utility and cost \$50 less per year to operate than the double conversion unit.

4. OUTPUT WAVE FORM AND POWER FACTOR

As previously mentioned in the input power quality discussion, the host utility must pay for the energy lost between the generator and the watt-meter. These losses are minimized when the load power factor is equal to 1.0. The same condition applies to the system operator between the power conditioner and the various cable plant electronic loads

The operator must pay for the transmission losses (I^2R) associated with both the base electronic load and any resulting power factor created by the powering wave form and the loads. Given that the base load and its characteristics are fixed, only the effects of power factor can be adjusted to reduce powering costs. This simple point has spawned a tempest of unsubstantiated claims and speculation regarding cost reductions in powering cable television plant through power factor improvements.

A power conditioner can influence the plant-side factor through any measure that implements or promotes time continuous current flow between the conditioner and the loads. When the trapezoidal voltage wave form of Figure 7 at the top of the page is applied to a coax feeder, the device power packs produce the corresponding current square wave form.

The power factor of a trapezoidal wave form is related to the duty cycle of the output current is shown on page 36 after the ECC '96 show guide section.

Duty cycle, D, is defined as:

$$D = t_1 / (t_1 + t_2) \quad (16)$$

The average or real component of the output current is:

$$I_{\text{real}} = I_{\text{peak}} * D \quad (17)$$

The apparent or RMS value of the output current is:

$$I_{\text{apparent}} = I_{\text{peak}} * D \quad (18)$$

Substituting equations (17) and (18) into equation (7) yields an alternate definition of power factor for a trapezoidal wave form:

$$PF = (I_{\text{peak}} * D) / (I_{\text{peak}} * \%D) = \%D \quad (19)$$

Thus, two measures are available to increase power factor (force D to approach 1.0): reducing the output frequency; and tailoring the output wave form. Obviously, reducing the powering frequency to nearly zero (DC), t1Y4, achieves continuous current flow and a power factor of 1.0. However, galvanic corrosion and a host of other issues become significant obstacles to reduced frequency powering.

The closest theoretical alternative to DC is a purely square voltage wave form, t 2=0. Such a wave form would achieve continuous current flow with a power factor of 1.0 due to the abrupt transitions in AC polarity.

However, such transitions are laden with high frequency harmonic energy that is known to adversely effect the RF transmission performance of the plant. To remove the high frequency harmonics, the AC transition rate (volts/second) of the wave form must be reduced. Industry experience has shown that the threshold of RF degradation due to AC transition slew rate is 300V per mS.

To assure a safety margin, most system operators specify a transition rate less than 150V per mS. Powering at 90 Volts, 60Hz, the required duty cycle is 0.926 and from equation (19), thus the maximum safe power factor is 0.96.

Controlled

Practically, the maximum power factor can only be approached if the power conditioner's output wave form is closely controlled. This can be the case with a double conversion system where the inverter can be tailored to closely regulated the wave form. Power factors of 0.92 to 0.94 can be achieved.

Most single ferro-transformer designs operate with a 100V per mS slew rate which produces a 0.94 maximum power factor improves. Power factors of 0.85 to 0.92 can be routinely achieved.

5. OUTPUT WAVE FORM AND 90V POWERING

As plant power requirements increase to accommodate new interactive and telephony market opportunities many system operators are planning to increase their powering voltage from 60 to 90 Volts. This measure affords greater power transmission efficiency and increases the service area of a power installation. The 90 Volt operating point is the National Electric Safety Code (NESC) limit for telecommunications powering with unrestricted VA capacity.

Measures

There are several measures of a powering signal's voltage such as peak, average, effective or root mean square (RMS). An official or legal clarification of the term "90 Volts" has yet to be made public. It is generally felt that the interpretation will be confident with other similar specifications that use RMS as the voltage definition.

However, the most conservative interpretation would be the peak value of a powering wave form.

It is apparent in Figure 7 on that as the frequency is reduced, t_1 Y4, the signal's peak, average and RMS values becomes equal, thus, removing any confusion about an official definition of "90 Volts". A similar result can be achieved with a 60Hz signal by letting t_2 Y0.

Slew Rate (Volts/ mS)	50	75	100	150	300*
Peak Voltage (Volts)	98	95	93	92	91
Max Power Factor	0.87	0.92	0.94	0.96	0.98

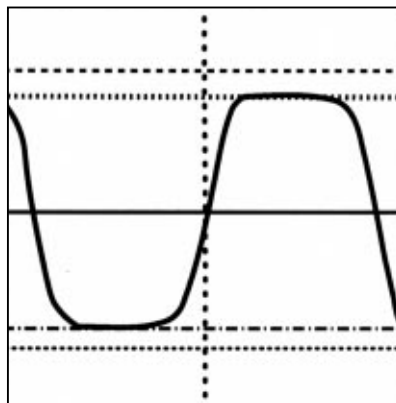

Figure 8: Double conversion design output voltage wave form

However, as previously mentioned, the side effects of the associated high frequency harmonics become detrimental to the plant's RF performance. The minimum peak voltages associated with a range of AC transition slew rates for a 90V RMS signal are listed in the table above.

In practice, a closely regulated output wave form, such as that available from a double conversion design, can approach these minimum peak voltage values across a wide output loading range Figure 8.

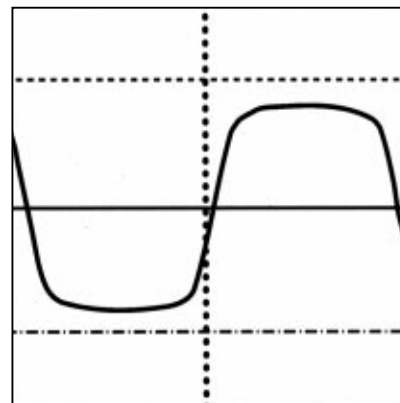

Figure 9: Single conversion design output voltage wave form

However, the system operator should be cautious of peak voltage claims below 95 Volts, the harmonic energy of the wave form may be considerable. The output wave form from a fully loaded single conversion transformer based design, operating with a 100 Volt mS slew rate, will crest 7 Volts higher than the calculated minimum. This results from a gradual rise in voltage during the t_1 interval. Figure 9 shows a single conversion output wave

6. LOAD COMPATIBILITY OF 90V POWER SUPPLIES AND PLANT LOADS

The operational characteristics of power packs used in broadband plant actives have evolved with ferro-based single transformer power supplies as their power source. The power supply's ferroresonant transformer automatically provides a safe manageable output that will not damage plant electronics in an overload or short circuit condition. This is achieved when the output voltage folds back once a maximum current is reached, as shown in V-I graph of Figure 10.

Efficient operation

Correspondingly, the constant power switch mode power packs are designed to provide the system operator with efficient operation over a reasonable input voltage range, while preventing low voltage lockup or oscillation caused by forcing the power supply to operate in its protective fold-back range. This condition can develop during transient conditions produced by sheath current fluctuations, outages, lightning strikes and the cold start of the coax feeder.

As shown in figure 10, the condition is avoided by implementing low voltage shutdown circuits in the power pack that prevent its operation below a minimum voltage limit. The limit corresponds with the voltage where the maximum output current from power supply is available. However, figure 10 is the power supply V-I response at its terminals, the power pack shutdown voltage range must be set slightly low to account for the voltage drop associated with the coax loop resistance.

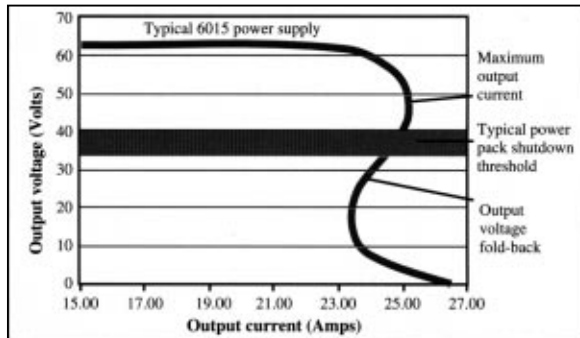

Figure 10: Typical 60V 15A power supply output response

As power pack location moves away from the power supply, the effective voltage scale of this V-I graph decreases. Thus, across a segment of coax, the power pack cut-off voltage approximates the voltage of the maximum output current for the pack's location.

Changing the plant powering voltage from 60 to 90 Volts will effect this tuned balance of relationships between plant safety, power supply and power pack characteristics. To gain fully the benefits of 90 Volt powering it is to the advantage of the system operator to leave the power pack shutdown point at its 60V powering level (35 to 40 Volts). This improves the available operating voltage range from 20 to 50 Volts, thus significantly increasing the reach of a power supply installation. However, if the ferro-based power supply design is simply scaled up to 90 Volts a stability problem can be created. The power packs can now operate down in the lower portion of the traditional fold-back range. The V-I response of the power supply must be corrected, as shown in Figure 11. This can be achieved by adjusting the short circuit current, setting it equal to the upper maximum current. A double conversion power supply design must also be tailored to provide this same V-I response. A CFR based design inherently provides a similar response as shown.

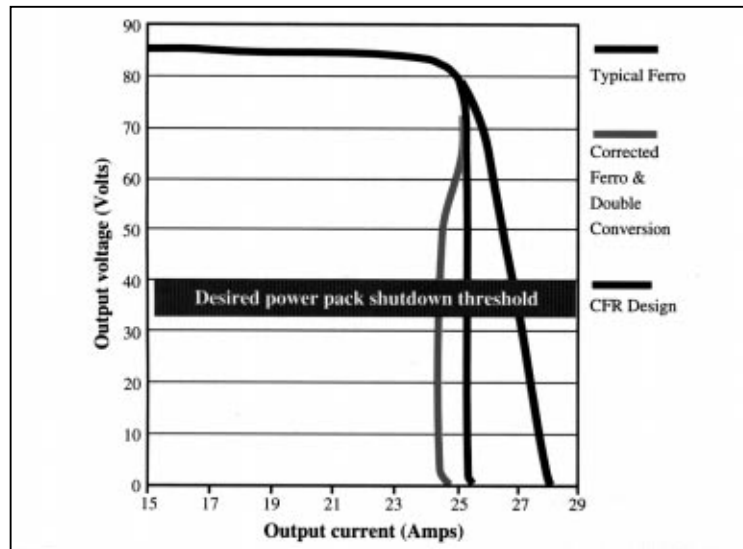
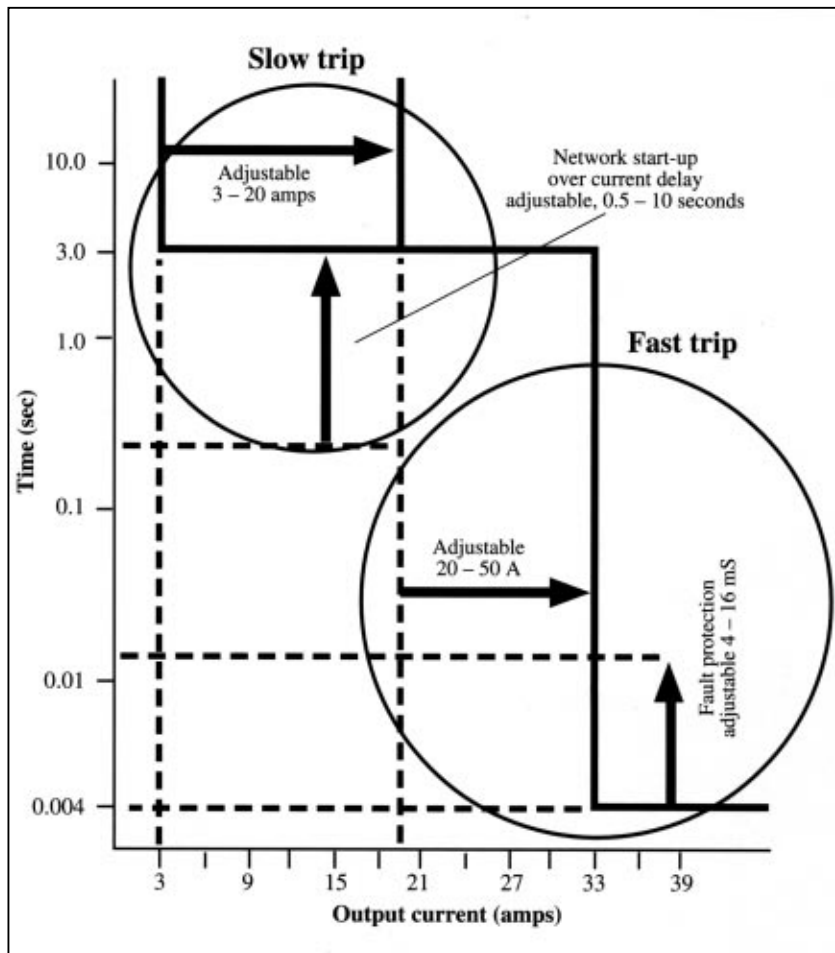

Figure 11: 90V 15A single transformer output overload response

Relying on any 90 Volt power supply's V-I response to protect plant electronics from over current damages is not likely to be acceptable in the future. At 90 Volts, the available energy to an overload increases by 150 per cent (90/60), thus the potential for associated equipment damage increases.

Customer service reliability will also mandate that service interruptions caused by overload or fault conditions be confined to the smallest possible service area. Thus some form of automatic circuit breaker function, for each coax feeder connected to a power supply, will be required to augment standard protection practices. This device must



be able to interrupt transient overloads and automatically re-establish power. It must also be able to distinguish between a transient over current condition and the normal overload conditions created during initial power up. The characteristics of such a device are illustrated in Figure 12.

Figure 12: Protective interface module circuit break time vs current

PLANT POWERING—COST TO THE OPERATOR

Based upon the previous discussion, the natural power technology of choice can be defined as:

1. Low in component count to reduce cost and increase reliability.
2. Vulnerable electronics should not be used continuously and not directly exposed to the outside plant.
3. The input power factor seen by the host utility should be greater than 0.9 to avoid potentially unfavorable electric power rates in the future.
4. The power conversion efficiency should be as high as possible under all load conditions. This is particularly important in telephony powering where loads can fluctuate based upon CCS loading.
5. The output wave form should result in the lowest possible power factor in the coax transmission system across a wide loading range. This is to be accomplished without degrading the RF performance of the plant.
6. The power supply's output response must be compatible with the operational characteristics of the plant's active device power packs.

DOUBLE CONVERSION DESIGN

1. Each stage of a double conversion design typically costs 0.70\$/W for a total of 1.40\$/W. Thus a 1,000 Watt system will cost \$1,400 for just the power processing components. The typical mean time between failure (MTBF) for each stage designed to telephony service standard in an N+1 redundancy configuration is approximately 256,000 hours.
2. The output inverter stage is directly connected to the outside plant; power processing electronics are used continuously.
3. Without power factor correction built into the input rectifier stage of the unit, the input power factor seen by the utility will be approximately 0.70. To provide correction, the rectifier must be equipped with an additional power factor correction stage (boost converter) which will reduce the rectifier's overall efficiency and approximately 1.60\$/W or \$1,600.
4. The power conversion efficiency of the two stages is directly dependent upon the class of power electronic technology utilized. The most advanced techniques available for the rectifier stage, including power factor correction, can provide a 91 per cent conversion efficiency. Using similarly advanced technology, the output inverter stage can be designed to provide a similar 91 per cent conversion efficiency for a combined efficiency of 83 per cent. Conversion efficiency over the load range of 25 to 85 per cent of rated full load is typically 69 per cent to 82 per cent.
5. As previously mentioned, the output wave form can be closely controlled over the output power range to provide a plant-side power factor in the range of 0.92 to 0.94. A peak wave form voltage of 94 to 96 Volts can be achieved.
6. The output V-1 characteristic of the inverter can be tailored to provide the required output over current protection without risk of low voltage lockup or oscillation.

SINGLE CONVERSION, FERRORESONANT DESIGN

1. A single conversion design typically cost 0.85\$/Watt. A 1,00 watt system will cost \$850 for just the power processing.
2. The vulnerable power electronics are not connected directly to the outside plant. They are protected by inductance inherent in the ferroresonant transformer design.
3. The resonant tank circuit of the ferroresonant conditioner naturally corrects the input power factor seen by the utility to 0.90 or greater.
4. Typically power conversion efficiencies of the unit at 85, 50 and 25 per cent of full load are 89,86 and 75 per cent respectively.
5. Under common conditions of 85 per cent loading using capacitive input loads, the plant power factor will typically be between 0.85 and 0.92. A peak wave form voltage of 100 to 105 volts can be achieved.
6. The output V-1 characteristic of the inverter can be tailored to provide the required output over current protection without risk of low voltage lockup or oscillation.



SINGLE CONVERSION, CONTROLLED FERRORESONANT DESIGN

1. A single conversion design typically cost 1.00\$/Watt. A 1,000 watt system will cost \$1000 for just the power processing.
2. The vulnerable power electronics are not connected directly to the outside plant. They are protected by inductance inherent in the ferroresonant transformer design.
3. The resonant tank circuit of the ferroresonant conditioner naturally corrects the input power factor seen by the utility to 0.98 or greater.
4. Typical power conversion efficiencies of the unit at 85,50 and 25 per cent of full load are 92,88 and 82 per cent respectively.
5. Under common conditions, 85 per cent loading using capacitive input loads, the plant power factor will typically be between 0.85 and .092. A peak wave form voltage of 100 to 105 Volts can be achieved.
6. The output V-1 characteristic of the inverter naturally provides the required output over current protection without risk of low voltage lockup or oscillation.

Performance Parameter	Double Conversion	Double Conversion W/PF Corr	Single Ferro Transformer	Single Cntr'd Ferro-Transformer
Cost per 100 Watts of power processing	\$1400	\$1600	\$850	\$1000
Precited MTBF	25,000 N+1	<25,000 N+1	>100,000	100,000
Input PF	0.60	0.98	0.90	0.98
Input Current THD	30%	<5% If corrected	<10%	<5%
Efficiency at 25% load	69%	67%	75%	82%
Efficiency at 50% load	80%	78%	86%	89%
Efficiency at 85% load	82%	80%	89%	93%
Plant PF at 25% load	0.94	0.94	0.87	0.87
Plant PF at 50% load	0.94	0.94	0.89	0.89
Plant PF at 85% load	0.94	0.94	0.91	0.91
Peak Output Voltage	95	95	105	105
Load Compatibility	OK, if properly designed	OK, if properly designed	OK, if properly designed	Automatically provides required response

Performance/ feature comparison