

Power



IDH3 Technical Manual DOCSIS® HMS Embedded Transponder

Effective: January 2010

Power

Alpha Technologies



IDH3

DOCSIS® HMS Embedded Transponder Installation and Technical Manual

745-420-B0-001, Rev. A
Effective Date: January 2010
Copyright© 2010
Alpha Technologies, Inc.
A Member of the Alpha Group

✓ **NOTE**

Alpha denies responsibility for any damage or injury involving its enclosures, power supplies, generators, batteries or other hardware, manufactured by Alpha or members of the Alpha Group, when used for an unintended purpose, installed or operated in an unapproved manner, or improperly maintained.

✓ **NOTE**

Photographs and drawings contained in this manual are only for illustrative purposes. These photographs and drawings may not exactly match your installation.

✓ **NOTE**

Review the written and illustrative information contained in this manual before proceeding. If there are questions regarding the safe installation or operation of this product, please contact Alpha Technologies or your nearest Alpha representative.

Contacting Alpha Technologies: *www.alpha.com*

OR

For general product information and customer service (7 AM to 5 PM, Pacific Time), call

1-800-863-3930

For complete technical support, call

1-800-863-3364

7 AM to 5 PM, Pacific Time or 24/7 emergency support

DOCSIS® is a Registered Trademark of CableLabs.

Table of Contents

Safety Notes	6
1.0 Introduction to the DOCSIS® Transponder	7
1.1 System Overview	8
1.2 LED Indicators	10
2.0 Transponder Installation	11
2.1 Provisioning the Transponder	11
2.1.1 Network Connectivity	11
2.1.2 Transponder Configuration	12
2.2 Verifying Firmware Version and Device Address	13
2.3 Installing the Transponder Hardware	13
2.4 RF Connection	15
2.5 Verifying Transponder Operation	15
3.0 Network/Element Management Software	16
3.1 Provisioning the SNMP Manager.....	16
4.0 Using the Ethernet (Craft) Port	17
4.1 IDH3 Web Interface	17
4.1.1 Overview	17
4.1.2 Status Page for Firmware Information	21
4.1.3 Status Page for Connection Information	22
4.1.4 Status Page for SNMP Event Log.....	23
4.1.5 HMS Power Supply Data Page.....	25
4.1.6 Generator Data Page.....	25
5.0 Specifications.....	26
6.0 Acronym Definitions.....	27

List of Figures

Fig. 1-1, IDH3 Transponder with EDSM	7
Fig. 1-2, System Interconnection Diagram 1	8
Fig. 1-3, System Interconnection Diagram 2	9
Fig. 2-1, Attaching the PCB Standoff.....	14
Fig. 2-2, Transponder Components.....	14
Fig. 2-3, RF Connection with Ground Block	15
Fig. 4-1, Status Page for Firmware Information.....	21
Fig. 4-2, Status Page for Connection Information	22
Fig. 4-3, Status Page for the SNMP Event Log.....	23
Fig. 4-4, HMS Power Supply Data Page	24
Fig. 4-5, Generator Data Page	25

Safety Notes

Review the drawings and illustrations contained in this manual before proceeding. If there are any questions regarding the safe installation or operation of the system, contact Alpha Technologies or the nearest Alpha representative. Save this document for future reference.

To reduce the risk of injury or death and to ensure the continued safe operation of this product, the following symbols have been placed throughout this manual. Where these symbols appear, use extra care and attention.

ATTENTION!

The use of ATTENTION indicates specific regulatory/code requirements that may affect the placement of equipment and /or installation procedures.



NOTE

A NOTE provides additional information to help complete a specific task or procedure.



CAUTION!

The use of CAUTION indicates safety information intended to PREVENT DAMAGE to material or equipment.



WARNING!

WARNING presents safety information to PREVENT INJURY OR DEATH to the technician or user.

1.0 Introduction to the DOCSIS® Transponder

The IDH3 Transponder for the XM2 power supply manages network powering through existing cable modem or high speed data infrastructure. A single transponder can monitor and manage multiple power supplies, multiple strings of batteries, and one generator. The transponder transmits data to a management system via the existing DOCSIS network. SNMP (Simple Network Management Protocol) keeps bandwidth use to a minimum. Status monitoring data is compatible with ANSI/SCTE HMS (Hybrid Management Sublayer) standards.

With optional VoIP test functionality, the power supply transponder becomes a powerful network diagnostics tool. Contact Alpha Technologies for more information.

Outstanding Features:

- Uses existing headend DOCSIS CMTS equipment.
- Uses ANSI/SCTE HMS standards.
- Single transponder supports up to six power supplies, two battery strings, and one generator.

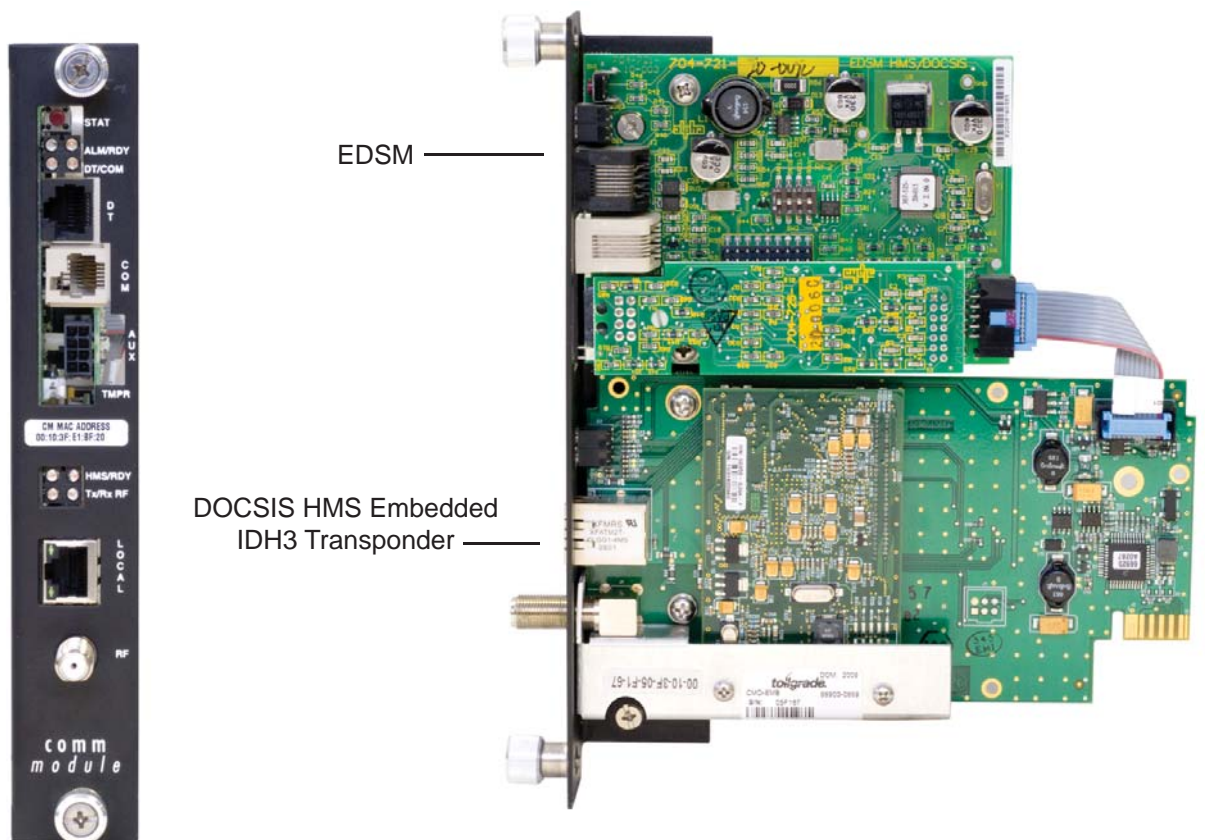

Fig. 1-1, IDH3 Transponder with EDSM

1.0 Introduction to the DOCSIS® Transponder, continued

1.1 System Overview

The IDH3 Transponder obtains data from the EDSM (Enhanced Digital Status Monitoring) interface card through an XM2 Power Supply. The EDSM collects data directly from the battery strings or from the AlphaBus Communications Network, depending on system configuration.

Equipment monitored (direct battery monitoring):

- An XM2 Power Supply
- One or two 36Vdc or 48Vdc battery strings
- One AlphaGen stationary generator system (if installed)

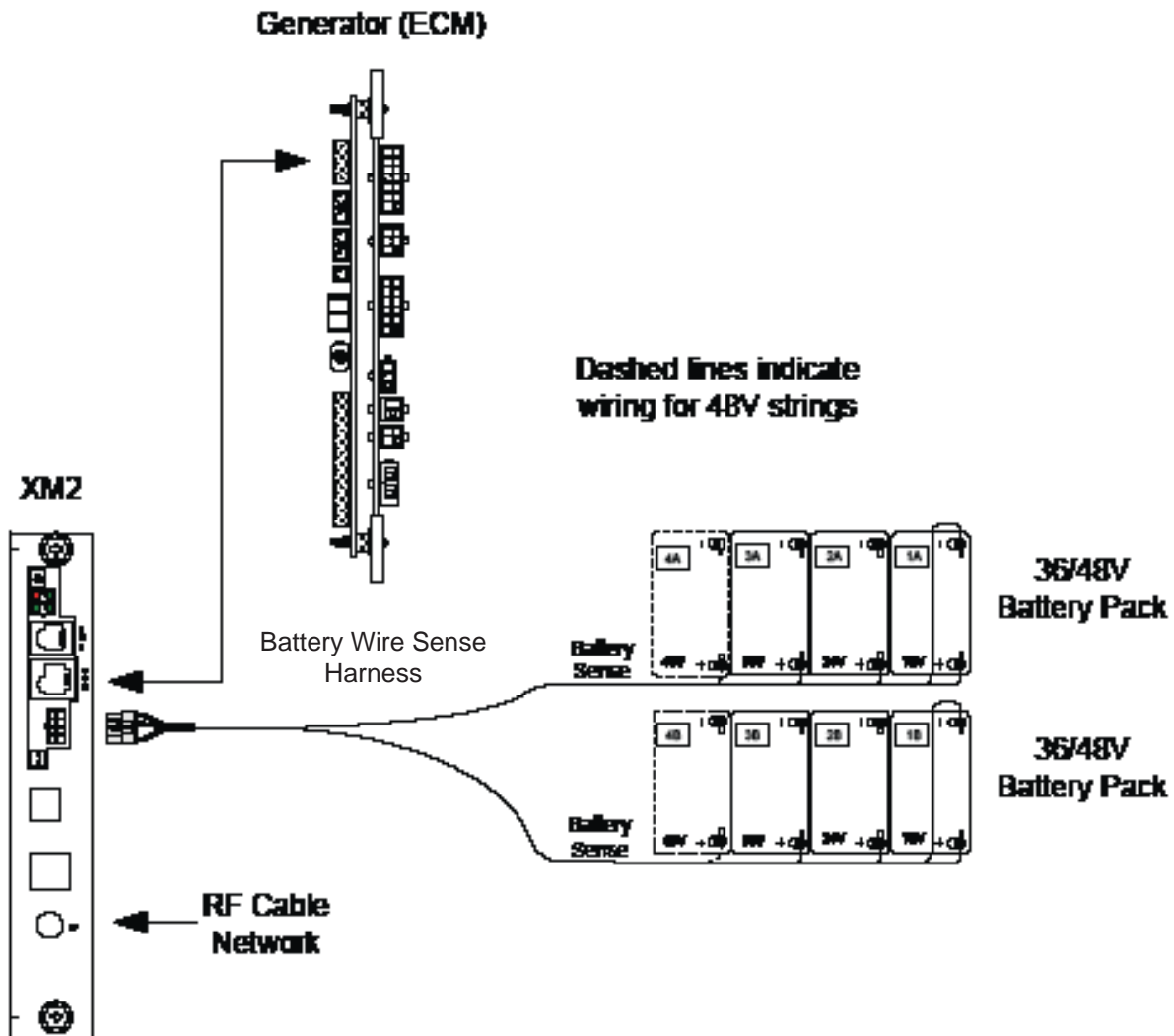

Fig. 1-2, System Interconnection Diagram 1

1.0 Introduction to the DOCSIS® Transponder, continued

1.1 System Overview, continued

Equipment monitored via the AlphaGuard™:

The AlphaGuard performs electrical compensation for differences in individual batteries in the string. The unit can be configured to pass measurements from the battery string to a status monitoring device (EDSM card, DOCSIS transponder, etc.) via an interface cable.

<u>Model</u>	<u>Description</u>
AG-CMT-3SC	AlphaGuard manages 3 batteries*
AG-CMT-4SC	AlphaGuard manages 4 batteries*

* Includes 6' battery cables

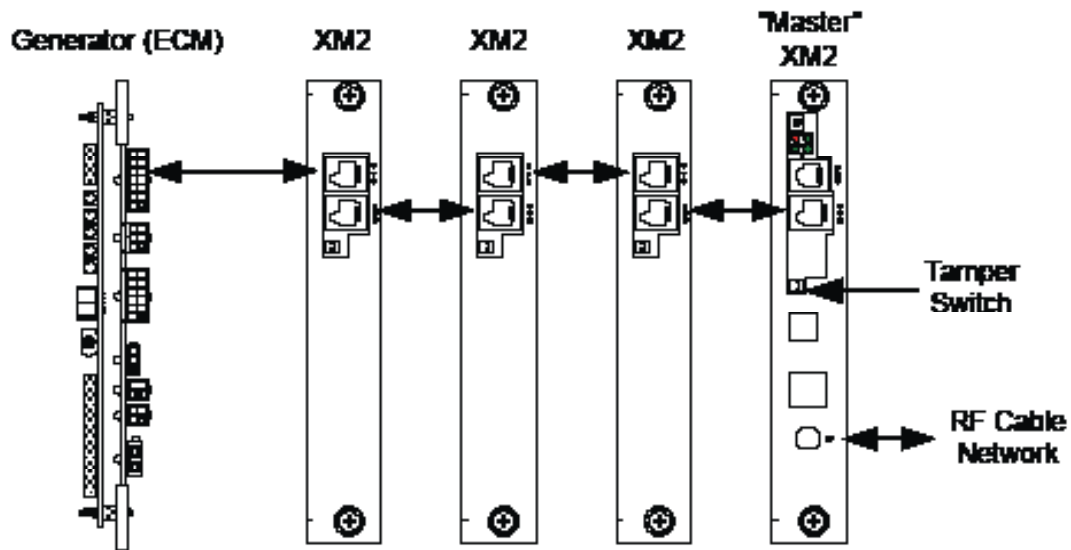

Fig. 1-3, System Interconnection Diagram 2

1.0 Introduction to the DOCSIS® Transponder, continued

1.2 LED Indicators



Communication State	HMS	RDY	Tx	Rx
Transponder Initializing	OFF and ON	OFF and ON	OFF and ON	OFF and ON
Searching for DOCSIS Downstream Channel	OFF	OFF and ON	OFF	OFF and ON
DOCSIS Channel Locked; Establishing Upstream IP Connectivity	OFF	OFF and ON	OFF and ON	ON
IP Connectivity Established; Registering with CMTS	OFF	OFF and ON	ON	ON
Registration Complete	OFF and ON	OFF and ON	ON	ON

2.0 Transponder Installation

Steps to a Successful Installation:

- Operator's IT Department must allow the transponder's Cable Modem (CM) to obtain an IP address from the DHCP Server.
- Operator's IT Department must provision the transponder, as described in the following section.
- Operator's network security policies must allow SNMP traffic to pass between transponder and SNMP manager.
- Install the transponder and any related equipment in the power supply.
- Connect an RF drop.
- Verify proper operation.

2.1 Provisioning the Transponders in the Network

Before installing transponders, the transponders must be provisioned in the network for the network to recognize, discover, and communicate with them when they are powered up. The following graphic shows a typical network.

2.1.1 Network Connectivity



NOTE:

Some provisioning systems require that the transponder's MAC address be added to the provisioning server prior to installing the transponder to achieve full functionality.

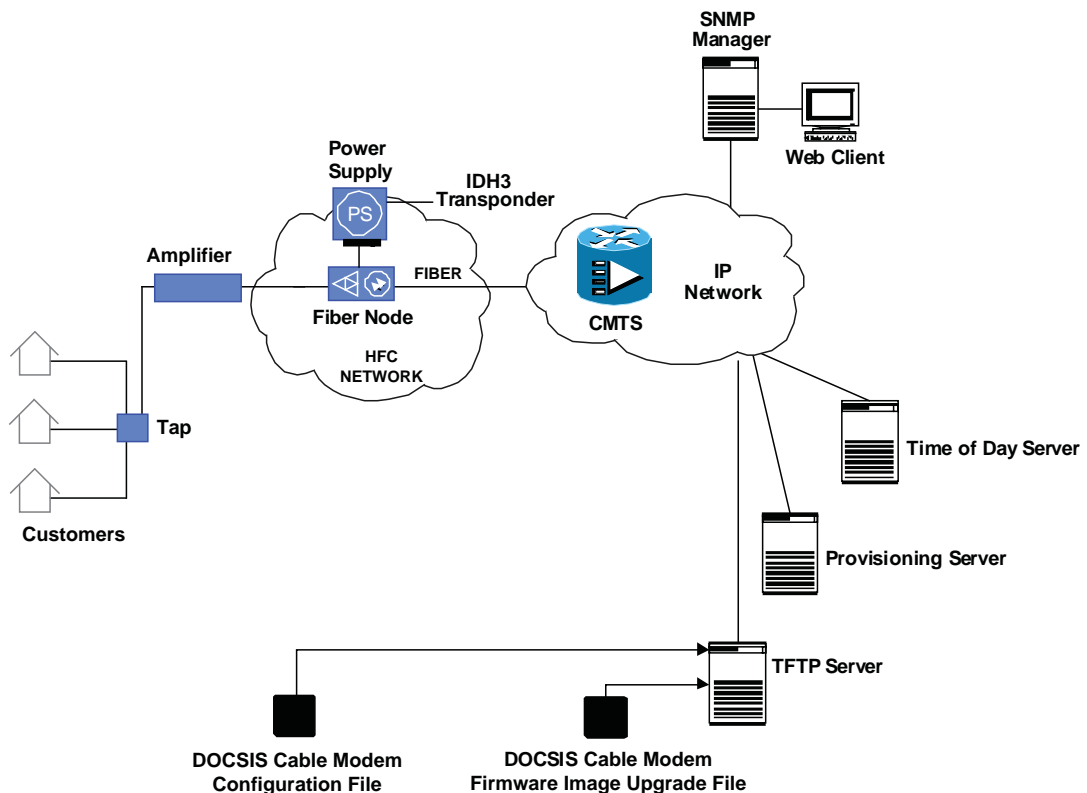

2.0 Transponder Installation, continued

2.1 Provisioning the Transponder, continued

2.1.2 Transponder Configuration

Many SNMP Management Applications require an SNMP Trap to be sent from the transponder for self-discovery and for alarm notifications. An SNMP Trap destination address can be specified to the IDH3 through the DOCSIS configuration files docsDevNmAccessTable (RFC 2669).

2.0 Transponder Installation, continued

2.2 Verifying Firmware Version and Device Address

Before removing the Inverter Module (IM), verify the power supply firmware version and device address are correct.

- IM firmware v3.00.0 is the minimum version compatible with the DOCSIS Embedded Transponder.
 - The power supply device address must not be set to zero, and no two power supplies monitored by a single transponder may have the same address.
1. Press the Enter key on the inverter module twice to access the SETUP Menu.
 2. Press the Down key until CODE VER is displayed.
 3. Verify that the firmware code is 3.00.0 or higher.
 4. Press the Down key twice until DEVICE ADDRESS is displayed.
 5. If the address is correct (and not zero), skip to Step 10.
 6. To change the address, press the Enter key to enter the Edit mode.
 7. Press the Up or Down key until the desired address (between 1 and 7) is displayed. Remember that each power supply on a single transponder must have a unique address.
 8. Press the Enter key to load the new address.
 9. Press the Enter key again to accept the new data.
 10. Press ESC three times to return to the OPERATION NORMAL screen.

2.3 Installing the Transponder Hardware



CAUTION!

The Embedded Transponder is static sensitive. An ESD wrist strap should be worn when installing the transponder.

Tools Required: #1 Phillips Screwdriver

1. Move the XM2 Battery Breaker to the OFF position.
2. Unplug all connections to the front of the Inverter Module (battery cable, RTS, etc).
3. Loosen the thumbscrews holding the Inverter Module into the power supply. Slide the Inverter Module out just enough to disconnect the ribbon cable. Now slide the Inverter Module out of the power supply.



WARNING!

To reduce the risk of electric shock, completely remove the Inverter Module from the Power Supply prior to installation.

2.0 Transponder Installation, continued

2.3 Installing the Transponder Hardware, continued

4. Attach the new transponder ribbon cable supplied to the 10-pin connector on the transponder. The connectors are keyed to prevent incorrect orientation.
5. Attach the plastic standoff to the transponder PC board as shown in Fig 2-1
6. Verify that the MAC address label is installed on the transponder. If the label is missing, locate the label in the packaging and apply to the transponder as shown in Fig 2-2.
7. Place the transponder as shown in Fig 2-2 below. The RF connector must be inserted through the front of the Comm Module bracket.
8. Press the standoff into the Inverter Module chassis.
9. Secure the transponder to the Comm Module Bracket with the two screws provided.
10. Connect the transponder ribbon cable to the EDSM. Note the 90° twist in the cable.
11. Reconnect the Inverter Module ribbon cable, and reinstall the Inverter Module into the power supply.
12. Reconnect all the cables unplugged in Step 2 .
13. Move the Battery Breaker to the ON position.



10-pin Connector

PCB Standoff

Fig. 2-1, Attaching the PCB Standoff

IDH3 COMPONENTS

- ① These two screws attach the transponder to the Communications Module bracket.
- ② Transponder ribbon cable connector
- ③ Location of PCB standoff
- ④ Transponder MAC address labels
- ⑤ Communications Module bracket (attaches to power supply Inverter Module).
- ⑥ RF Connector

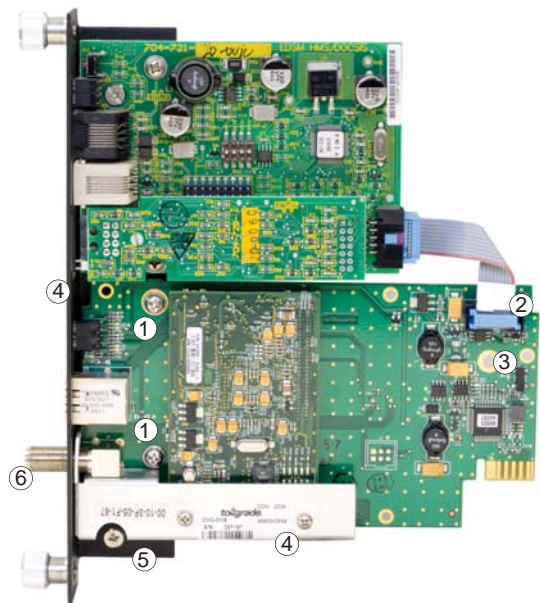

Fig. 2-2, Transponder Components

2.0 Transponder Installation, continued

2.4 RF Connection

Connect the RF drop to the RF connector on the transponder. The drop must have a properly installed ground block in or on the power supply enclosure. Recommended forward RF level is 0 dBmV.

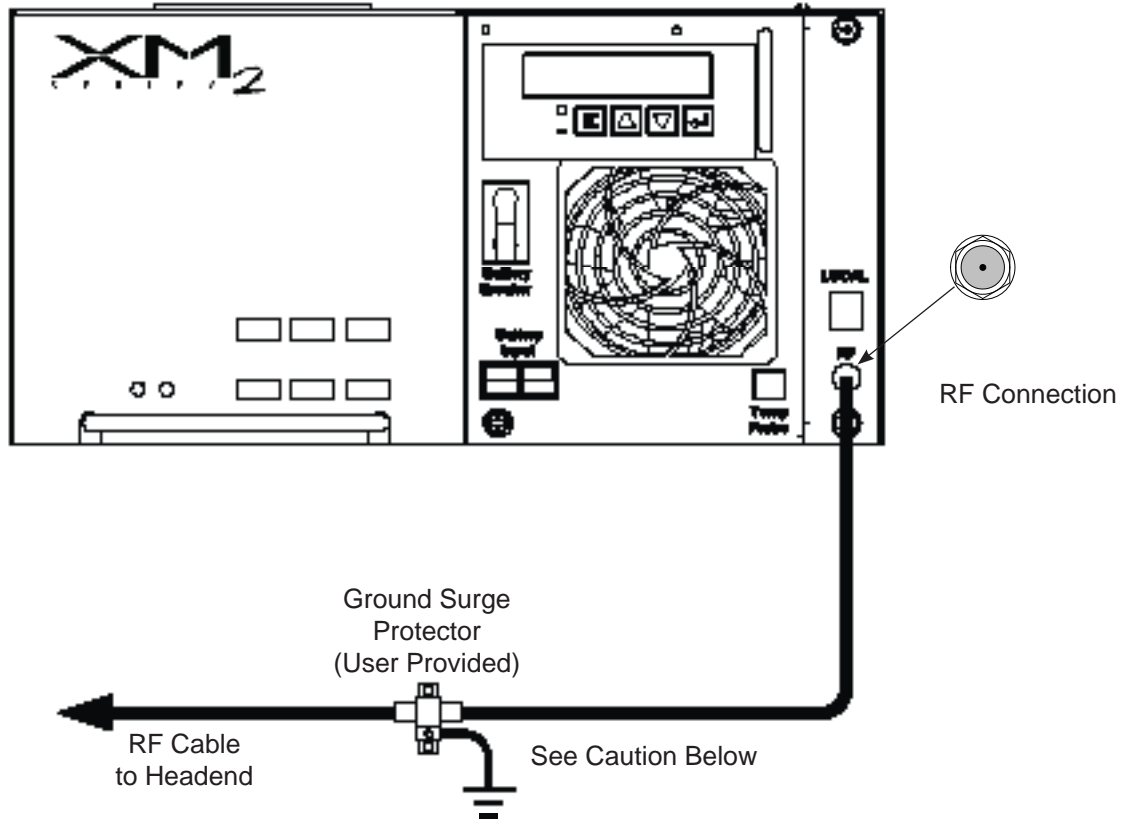

Fig. 2-3, RF Connection with Ground Block



CAUTION!

Alpha requires installing a grounded surge suppressor (Alpha P/N 162-028-10 or equivalent).

2.5 Verifying Transponder Operation

The LED behavior per the table below shows the status of LEDs during transponder operation:

Communication State	HMS	RDY	Tx	Rx
Transponder Initializing	OFF and ON	OFF and ON	OFF and ON	OFF and ON
Searching for DOCSIS Downstream Channel	OFF	OFF and ON	OFF	OFF and ON
DOCSIS Channel Locked; Establishing Upstream IP Connectivity	OFF	OFF and ON	OFF and ON	ON
IP Connectivity Established; Registering with CMTS	OFF	OFF and ON	ON	ON
Registration Complete	OFF and ON	OFF and ON	ON	ON

3.0 Network/Element Management Software

3.1 Provisioning the SNMP Manager

The following MIB (Management Information Base) files are required for the SNMP Manager to collect data from the transponders. These files can be found on the Society of Cable Telecommunications (SCTE) web site www.scte.org. There are dependencies between MIB files so they should be compiled in the following order listed below:

[ANSI/SCTE 36 2002R2007](#) (formerly HMS 028), SCTE-ROOT Management Information Base (MIB) Definitions

[ANSI/SCTE 37 2008](#) (formerly HMS 072), Hybrid Fiber/Coax Outside Plant Status Monitoring SCTE-HMS-ROOTS Management Information Base (MIB) Definition

[ANSI/SCTE 38-1 2009](#) (formerly HMS 026), Hybrid Fiber/Coax Outside Plant Status Monitoring SCTE-HMS-PROPERTY-MIB Management Information Base (MIB) Definition

[ANSI/SCTE 38-2 2005](#) (formerly HMS 023), Hybrid Fiber/Coax Outside Plant Status Monitoring SCTE-HMS-ALARMS-MIB Management Information Base (MIB) Definition

[ANSI/SCTE 38-3 2008](#) (formerly HMS 024), Hybrid Fiber/Coax Outside Plant Status Monitoring SCTE-HMS-COMMON-MIB Management Information Base (MIB) Definition

[ANSI/SCTE 38-4 2006](#) (formerly HMS 027), Hybrid Fiber/Coax Outside Plant Status Monitoring SCTE-HMS-PS-MIB Management Information Base (MIB) Definition

[ANSI/SCTE 38-6 2006](#) (formerly HMS 033) Hybrid Fiber/Coax Outside Plant Status Monitoring - SCTE-HMS-GEN-MIB Management Information Base (MIB) Definition

[ANSI/SCTE 38-7 2008](#) (formerly HMS 050), Hybrid Fiber/Coax Outside Plant Status Monitoring SCTE-HMS-Transponder-Interface-Bus(TIB)-MIB Management Information Base (MIB) Definition

4.0 Using the Ethernet (Craft) Port

4.1 IDH3 Web Interface

4.1.1 Overview

A web interface is available on the IDH3 transponder. The default port for HTTP traffic is port 80, but can be configured to use other ports via the Tollgrade httpMgmt MIB. HTTP port configuration is available for the cable modem interface (via the cable modem IP address) and the CPE interface (via the Local connection). The Local connection's IP address is 192.168.100.1, and may be easily accessed by using a standard CAT5 patch cord between a computer and the ETHERNET port on the front of the transponder.

The interface can be accessed by typing the cable modem IP address of the transponder into your web browser. The interface includes status data for the cable modem, the HMS transponder, High Speed Internet Access (HSIA) diagnostics, the RF constellation page and equalizer page, and the MTA (Media Terminal Adapter) in VoIP systems.

4.0 Using the Ethernet (Craft) Port, continued

4.1 IDH3 Web Interface, continued

4.1.1 System Overview, continued

Depending on the network configuration of the computer you are using to connect to the IDH3 transponder, it may be necessary to set the network interface to a temporary static IP address. This will make itself known if you can't bring up the first web page using 192.168.100.1. Here's how to resolve that issue, and connect to the transponder:

Click on the "start" button (lower left button on most Windows computers). When the window pops up, right-click on "Network" (usually about half the way down the second column).

Click on the bottom option, "Properties," and right-click on the network interface you are using. You'll see a dialog box much like the one below; scroll down to the entry "Internet Protocol (TCP/IP)" and then click on "Properties."

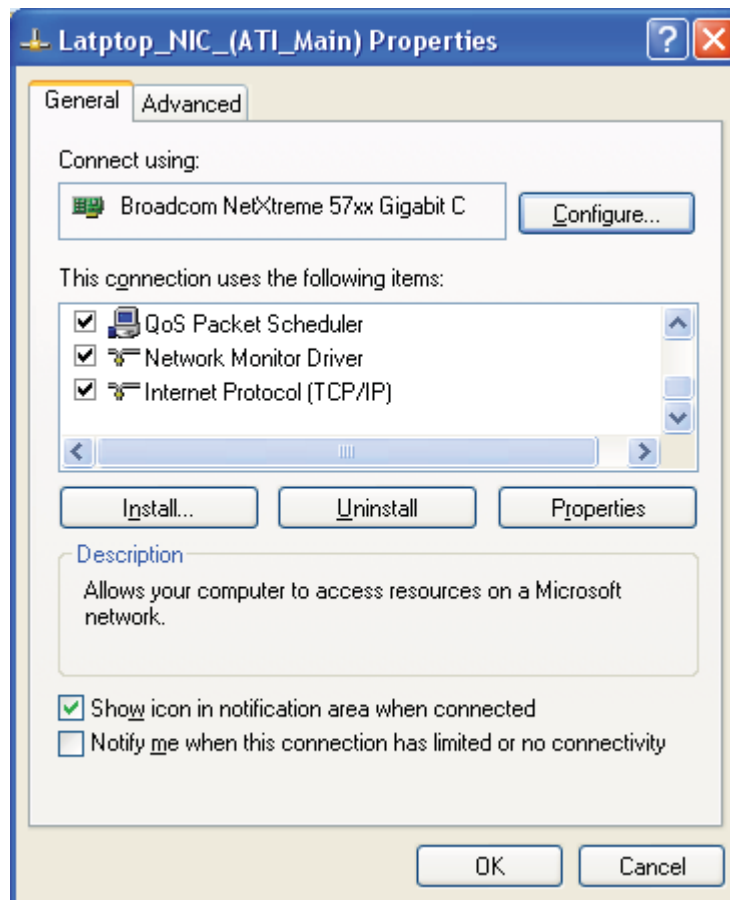

4.0 Using the Ethernet (Craft) Port, continued

4.1 IDH3 Web Interface, continued

4.1.1 System Overview, continued

You'll see another dialog box, and enter the values as they appear in the diagram below:

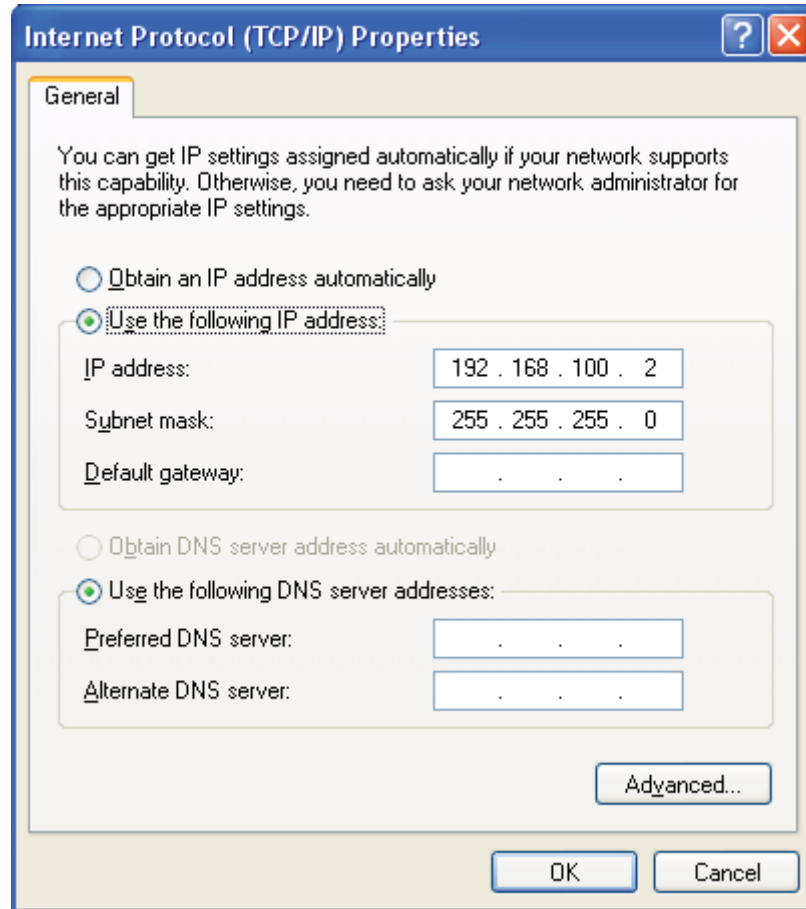

Click on "OK" and try to connect to the transponder once again using 192.168.100.1 in your Web browser.

4.0 Using the Ethernet (Craft) Port, continued

4.1 IDH3 Web Interface, continued

4.1.1 System Overview, continued

**NOTE:**

The IDH3 web pages do not automatically refresh, so the user must manually reload each one to view the most current data.

Configuring the sysName and sysLocation OIDs

It is also possible to configure the sysName (1.3.6.1.2.1.1.5.0) and sysLocation (1.3.6.1.2.1.1.6.0) OIDs from the web interface. This feature is password protected. There are both Admin and User usernames and passwords. Both usernames (Admin and User) have the authority to set sysName and sysLocation. The passwords can be changed via the Broadcom httpMgmt MIB. The specific OIDs and default values are shown below.

Parameter	OID	Default
httpAdminId	1.3.6.1.4.1.4413.2.2.2.1.1.3.1.0	edarglloT
httpAdminPassword	1.3.6.1.4.1.4413.2.2.2.1.1.3.2.0	aDm1n\$TR8r
httpUserId	1.3.6.1.4.1.4413.2.2.2.1.1.3.3.0	Tollgrade
httpUserPassword	1.3.6.1.4.1.4413.2.2.2.1.1.3.4.0	Tollgrade

It is possible to change the port number for Web Access and to disable it entirely. The table below lists the Parameters, OIDs, and default settings. Setting the Port value to zero (0) will disable access to the HTTP server for the given interface. The specific OIDs and their default values are listed in Table 6. The port must be open to use all of the features described in the following sections.

Parameter	OID	Default
httpCMMgmtPort	1.3.6.1.4.1.2082.5.5.1.1.1.0	80
httpCPEMgmtPort	1.3.6.1.4.1.2082.5.5.1.1.2.0	80

4.0 Using the Ethernet (Craft) Port, continued

4.1 IDH3 Web Interface, continued

4.1.2 Status Page for Firmware Information

This homepage provides details on the firmware running in the cable modem and allows navigation to other diagnostic information via the links provided..

The screenshot displays the tollgrade web interface. At the top, a navigation bar includes links for Status, HMS, Config, HSIA, RF, and MTA. The Status page is active, showing the tollgrade logo and a sidebar with buttons for Software, Connection, and Event Log. The main content area is titled 'Status' and contains a 'Software' section with a description. Below this are two tables: 'Information' and 'Status', each with a red header. The 'Information' table lists system details like compliance, hardware version, software version, MAC address, serial number, and certificate status. The 'Status' table shows system up time, network access, and IP address.

Information	
Standard Specification Compliant	DOCSIS 2.0
Hardware Version	b302
Software Version	3.7.0 Build x CxC 3.9.17
Cable Modem MAC Address	00:10:3f:22:00:07
Cable Modem Serial Number	220007
CM certificate	Not Installed

Status	
System Up Time	0 days 18h:44m:15s
Network Access	Allowed
Cable Modem IP Address	172.16.3.185

Fig. 4-1, Status Page for Firmware Information

4.0 Using the Ethernet (Craft) Port, continued

4.1 IDH3 Web Interface, continued

4.1.3 Status Page for Connection Information

This page provides detailed status information related to the current connection to the CMTS.

The screenshot shows the tollgrade web interface. At the top, there is a navigation bar with tabs for Status, HMS, Config, HSIA, RF, and MTA. The Status tab is selected. On the left side, there is a sidebar with the tollgrade logo and three buttons: Software, Connection (highlighted in yellow), and Event Log. The main content area is titled "Status" and contains the following information:

Connection
This page displays information on the status of the cable modem's HFC and IP network connectivity.

Startup Procedure

Procedure	Status	Comment
Acquire Downstream Channel	477000000 Hz	Locked
Connectivity State	OK	Operational
Boot State	OK	Operational
Configuration File	OK	cmdn_john.cfg
Security	Disabled	Disabled

Downstream Channel

Lock Status	Locked	Modulation	QAM256
Channel ID	2	Symbol rate	5360537
Downstream Frequency	477000000 Hz	Downstream Power	22.6 dBmV
SNR(RxMER)	44.6 dB		

Upstream Channel

Lock Status	Locked	Modulation	QAM16
Channel ID	3	Symbol rate	2560 Ksym/sec
Upstream Frequency	320000000 Hz	Upstream Power	12.0 dBmV

CM IP Address

CM IP Address	Duration	Expires
172.16.3.40	D: 02 H: 00 M: 00 S: 00	Sat Aug 30 08:32:27 2008

Current System Time: Thu Aug 28 08:37:43 2008

Fig. 4-2, Status Page for Connection Information

4.0 Using the Ethernet (Craft) Port, continued

4.1 IDH3 Web Interface, continued

4.1.4 Status Page for the SNMP Event Log

This page provides recent event log entries.

The screenshot shows the 'Status' page of the tollgrade web interface. The top navigation bar includes 'Status', 'HMS', 'Config', 'HSIA', 'RF', and 'MTA'. The 'Status' page title is displayed, followed by the 'SNMP Event Log' section, which states: 'This page displays the contents of the SNMP event log.' On the left side, there are three buttons: 'Software', 'Connection', and 'Event Log', with 'Event Log' being the active selection. The main content area displays a table of event log entries.

Time	Priority	Description
Time Not Established	Critical (3)	DHCP WARNING - Non-critical field invalid in response.
Time Not Established	Critical (3)	DHCP FAILED - Discover sent, no offer received
Time Not Established	Critical (3)	No Ranging Response received - T3 time-out
Time Not Established	Critical (3)	DHCP FAILED - Discover sent, no offer received
Time Not Established	Critical (3)	No Ranging Response received - T3 time-out
Time Not Established	Critical (3)	DHCP FAILED - Discover sent, no offer received
Time Not Established	Critical (3)	No Ranging Response received - T3 time-out
Thu Oct 02 06:35:42 2008	Critical (3)	Received Response to Broadcast Maintenance Request, But no Un...
Thu Oct 02 06:35:16 2008	Critical (3)	Telnet user logged out.
Thu Oct 02 06:34:53 2008	Error (4)	Configuration File CVC Validation Failure
Thu Oct 02 06:34:52 2008	Critical (3)	DHCP WARNING - Non-critical field invalid in response.
Thu Oct 02 06:34:34 2008	Error (4)	Configuration File CVC Validation Failure
Thu Oct 02 06:34:33 2008	Critical (3)	DHCP WARNING - Non-critical field invalid in response.
Time Not Established	Critical (3)	SYNC Timing Synchronization failure - Failed to acquire QAM/Q...
Thu Oct 02 06:34:15 2008	Error (4)	Configuration File CVC Validation Failure
Thu Oct 02 06:34:15 2008	Critical (3)	DHCP WARNING - Non-critical field invalid in response.

Fig. 4-3, Status Page for the SNMP Event Log

4.0 Using the Ethernet (Craft) Port, continued

4.1 IDH3 Web Interface, continued

4.1.5 HMS Power Supply Data Page

This page displays HMS power supply, generator, and generic I/O data.

The coloring of an individual parameter indicates its alarm level as follows:

- Light grey: Parameter is not in alarm.
- Yellow: Parameter is in minor alarm.
- Red: Parameter is in major alarm.

The screenshot shows the HMS Power Supply Data Page. At the top, there is a navigation bar with tabs for Status, HMS (selected), Config, HSIA, RF, and MTA. The tollgrade logo is on the left. Below the logo are two buttons: HMS Data and HELP. The main content area is titled HMS and HMS Data, with a subtitle stating 'This page displays information on the current HMS device data.' There are three sub-sections: PS1, GEN8, and Generic I/O. The PS1 Device Data table lists various parameters such as Device ID, Control Mode, Inverter Status, Major Alarm, Minor Alarm, Tamper, Input Voltage, Frequency In, Output Voltage, Output 1 Current, Power Out, String 1 Charge Current, String 1 Discharge Current, Temperature Sensor 1 Temperature, and Total String Voltage. The PS1 Battery Data table lists String 1 Battery 1 Voltage, String 1 Battery 2 Voltage, and String 1 Battery 3 Voltage.

PS 1 Device Data		
Measurement/OID	Data	Units
Device ID	Alpha XMS2 Power Supply (eDSM)	
Control Mode	remote	
Inverter Status	off	
Major Alarm	noAlarm	
Minor Alarm	alarm	
Tamper	open	
Input Voltage	118.80	V
Frequency In	60	Hz
Output Voltage	64.00	V
Output 1 Current	0.00	A
Power Out	0	W
String 1 Charge Current	0.00	A
String 1 Discharge Current	0.00	A
Temperature Sensor 1 Temperature	30	°C
Total String Voltage	43.30	V

PS 1 Battery Data		
Measurement/OID	Data	Units
String 1 Battery 1 Voltage	14.60	V
String 1 Battery 2 Voltage	14.50	V
String 1 Battery 3 Voltage	14.20	V

Fig. 4-4, HMS Power Supply Data Page

4.0 Using the Ethernet (Craft) Port, continued

4.1 IDH3 Web Interface, continued

4.1.6 Generator Data Page

Click on the GEN8 link to see the Generator data page.

The screenshot displays the HMS Data page. At the top, there is a navigation bar with tabs for Status, HMS (highlighted), Config, HSIA, RF, and MTA. On the left side, there is a vertical sidebar with the tollgrade logo and two buttons: HMS Data and HELP. The main content area is titled HMS and contains the text 'HMS Data' and 'This page displays information on the current HMS device data.' Below this, there are three links: PS1, GEN8 (highlighted), and Generic I/O. A table titled 'GEN 8 Device Data' is displayed, showing various measurements and their current values.

GEN 8 Device Data		
Measurement/OID	Data	Units
Device ID	Alpha XMS2 Power Supply (eDSM)	
Control Mode	local	
Generator Status	fail	
Gas Hazard	noAlarm	
Water Intrusion	noAlarm	
Pad Shear	noAlarm	
Enclosure Door	noAlarm	
Charger	noAlarm	
Fuel	noAlarm	
Ignition Battery Voltage	13.00	V
Enclosure Temperature	21	°C

Fig. 4-5, Generator Data Page

5.0 Specifications

Power Supplies Supported:	XM2-HP, XM2
DOCSIS Compatibility:	DOCSIS 1.1, 2.0
Monitoring Protocol:	SNMP v1
Devices Monitored:	Power Supply, Batteries and Generator (compatible with ANSI/SCTE 25-3 2002, formerly HMS 022)

Hardware

RF Cable Interface:	F-connector, female, 75Ohm
Local Interface:	Ethernet interface for direct web page access to diagnostic information.
LED Indicators:	Transponder Ready/RF Link Established Transponder/CMTS Communications Power Supply/Transponder Communication

Environmental

Operating Temperature:	-40 to 65°C / -40 to 149°F
Humidity:	10 to 90% non-condensing
Emissions:	EN50022 Class A and FCC Part 15 Class A (Installed in power supply enclosure system)

RF Transmit/Receive

Tx Frequency Range:	5 to 42MHz
Output Power:	8 to 58dBmV
Channel Bandwidth:	6MHz
Receive Center Frequency Range:	91 to 857MHz (Standard, HRC, IRC channels)
Input Level:	-15 to 15dBmV

Power Supply Monitored Parameters

Major Alarm:	Logical (OR) of: test fail, battery fail, line isolation alarm, output overload, inverter over temperature, N+1 active, fuse fail
Minor Alarm:	Logical (OR) of: temperature probe error, AC line loss, N+1 error
Input Line Voltage:	90 to 270Vac 50/60Hz measured value
Output Voltage:	60/90Vac measured value
Output Current 1:	0 to 25A measured value
Output Current 2, 3, 4:	0 to 25A measured value (if optional ports installed)
Output Power:	Calculated, reported in AC Watts
UPS Status:	AC line, Standby, Test in-process, Test alarm
Enclosure Door:	Open/Closed
Battery Voltage:	6 or 12V batteries, up to 4 battery strings Individual battery voltages measured reported to ±100mv resolution
Battery Temperature:	Measured, reported in Celsius
Remote Test Control:	Start/Stop XM2 self test cycle

Generator Monitored Parameters

Status:	Engine off, running, alarm Aggregate alarm consisting of: low oil pressure, engine over-temp, engine over- speed, crank limit, over voltage, low fuel, water intrusion, pad shear, gas hazard, test fail
Generator Alarm:	
Gas Hazard:	OK, Alarm
Water Intrusion:	OK, Alarm
Pad Shear:	OK, Alarm
Enclosure Door:	Open, Alarm
Ignition Battery Voltage:	10.2 to 15.5Vdc, 100mV resolution
Enclosure Temperature:	-40 to 100°C / -40 to 212°F
Low Fuel:	OK, Alarm
Remote Test:	Start and Stop control input

6.0 Acronym Definitions

ANSI:	American National Standards Institute
CM:	Cable Modem
CMTS:	Cable Modem Termination System
DHCP:	Dynamic Host Configuration Protocol
DOCSIS:	Data Over Cable Service Interface Specification
EDSM:	Enhanced Digital Status Module
EMS:	Element Management System
IT:	Information Technology
MAC:	Media Access Control
MIB:	Management Information Base
NMS:	Network Management System
QoS:	Quality of Service
SCTE-HMS:	Society of Cable Telecommunications Engineers-Hybrid Management Sublayer
SI:	Serial Interface
SNMP:	Simple Network Management Protocol
TFTP:	Trivial File Transfer Protocol
TOD:	Time of Day
UDP:	User Datagram Protocol
VoIP:	Voice over Internet Protocol

Power

Alpha Technologies



Alpha Technologies
3767 Alpha Way
Bellingham, WA 98226
USA
Tel: +1 360 647 2360
Fax: +1 360 671 4936
Web: www.alpha.com

Alpha Technologies Ltd.
4084 McConnell Court
Burnaby, BC, V5A 3N7
CANADA
Tel: +1 604 430 1476
Fax: +1 604 430 8908

Alpha Technologies
Europe Ltd.
Twyford House Thorley
Bishop's Stortford
Hertfordshire CM22 7PA
UNITED KINGDOM
Tel: +44 0 1279 501110
Fax: +44 1 279 659870

Alpha Technologies GmbH
Hansastraße 8
D 91126 Schwabach
GERMANY
Tel: +49 9122 79889 0
Fax: +49 9122 79889 21

Alphatec, Ltd
339 St. Andrews Street
Suite 101 Andrea Chambers
3307 Limassol
CYPRUS
Tel: +357 25 375675
Fax: +357 25 359595

AlphaTEK ooo
Khokhlovskiy Pereulok 16
Stroenie 1 Office 403
109028 Moscow
RUSSIA
Tel: +7 495 916 1854
Fax: +7 495 916 1349

Alphatec Baltic
S. Konarskio Street G.49-201
Vilnius LT-03123
LITHUANIA
Tel: +370 5 210 5291
Fax: +370 5 210 5292

Alpha Technologies
34, Grande Rue
Bétheny, F-51450
France
Phone: +33 32 64990 54
Fax: +33 67 54289 44