

# Powernode System Enclosures



## Site Preparation and Installation

**PN-3** Models  
**PN-4** Models

*Effective: March, 2002*

[Power]

[www.alpha.com](http://www.alpha.com) Protecting The Power in Communications.

# Powernode System Enclosures

## PN-3, PN-4 Models

### Site Preparation and Installation

031-103-B0-003 Rev. C — © 2002 Alpha Technologies

This manual covers the installation of the PN-3 and PN-4 Enclosure. Installation may involve connection to the electrical utility lines and fuel vapor (Natural Gas or Propane). Always work with the local utilities when connecting the enclosure to these utilities and observe all local and national laws which may be applicable for your area. Refer to Section 2, Pre-Installation, for site planning and preparation.

Photographs contained in this manual are for illustrative purposes only. These photographs may not exactly match your installation.

Review the drawings and illustrations contained in the manual before proceeding. If there are questions regarding the safe installation and operation of this enclosure or the Powering System, please contact Alpha Technologies or your nearest Alpha representative.

### To contact Alpha Technologies:

For general **product information and customer service**

**1-800-863-3930**

*(7:00 AM to 5:00 PM Pacific Time )*

For complete **technical support**

**1-800-863-3364**

*(7:00 AM to 5:00 PM Pacific Time, or 24/7 emergency support)*

## Table of Contents

<b>Product Safety</b> .....	<b>6</b>
Important Notes About Installation .....	7
Product Information, Customer Service or Technical Support .....	8
<b>1. Introduction</b> .....	<b>9</b>
1.1 Introduction .....	9
1.2 PN-3 and PN-4 Powernode Enclosure .....	10
<b>2. Pre-Installation</b> .....	<b>11</b>
2.1 Site Preparation .....	11
2.2 Concrete Pad Preparation .....	12
2.3 Enclosure Grounding .....	13
<b>3. Installation</b> .....	<b>15</b>
3.1 Transportation and Lifting .....	15
3.2 Enclosure Mounting Procedure .....	15
3.3 Utility Powering .....	16
3.3.1 Connection Procedure for the BBX-100A-8POS Service Disconnect: .....	17
3.3.2 Connection Procedure for the BBX-70A Service Disconnect: .....	18
3.3.3 Sample Input Power Panels .....	19
3.4 Coaxial Cable to Service Power Inserter (SPI) Installation .....	22
3.4.1 SPI to Ground Bar Connection Procedure .....	22
3.4.2 Conduit Placement .....	23
3.5 Battery Installation .....	24
3.5.1 Battery Safety Notes .....	24
3.5.2 Battery Identification .....	25
3.5.3 Battery Terminal Connections .....	25
3.5.4 Battery Terminal Assembly Procedure .....	26
3.5.5 Battery Installation Procedure .....	26
3.5.6 Battery Installation Layout .....	27
3.5.7 Battery Temperature Sensor .....	32
<b>4. PN Series Options</b> .....	<b>33</b>
4.1 Star Lock Security Bolt .....	33
4.2 Battery Interface Unit (BIU) .....	34
4.3 Service Disconnects .....	34
4.4 Input Power Panel (IPP) .....	35
4.5 Cooling Fan Kit .....	36
4.6 Lightning Arrester (LA-P+) .....	37
<b>5. Alpha Part Numbers</b> .....	<b>38</b>
5.1 PN Series Options .....	38
5.2 Pre-Cast Concrete Pads .....	39

## List of Figures

Figure 1-1; Enclosure as it Arrives from Alpha .....	9
Figure 1-2; Packing Label Location .....	9
Figure 1-3; PN-3 Specifications .....	10
Figure 1-4; PN-4 Specifications .....	10
Figure 2-1; Suggested Site Selection, PN-3 and PN-4 .....	11
Figure 2-2; Single-Wide Concrete Pad for PN-3 and PN-4 .....	12
Figure 2-3; Suggested Grounding, PN-3 and PN-4 .....	13
Figure 2-4; Alternate Grounding, PN-3 and PN-4 .....	14
Figure 3-1; PN-3 Mounted to the Prepared Pad .....	15
Figure 3-2; BBX-100A-8POS Service Disconnect .....	17
Figure 3-3; BBX-70A Service Disconnect .....	18
Figure 3-4; Schematic: Primary Service BBX-100A-8POS with IPP-240-3 .....	19
Figure 3-5; Schematic: Primary Service BBX-100A-8POS with IPP-120-3 .....	19
Figure 3-6; Schematic: Secondary Service BBX-100A-8POS with IPP-120-2 .....	20
Figure 3-7; Schematic: Secondary Service BBX-100A-8POS with IPP-240-2 .....	20
Figure 3-8; Schematic: Secondary Service BBX-70A with IPP-120-1 .....	21
Figure 3-9; Schematic: Primary Service BBX-70A with IPP-240-1 .....	21
Figure 3-10; Connector Fitting in Rear of Equipment Tray .....	22
Figure 3-11; Location of SPI in Equipment Tray .....	22
Figure 3-12; SPI Ground Wire Connected to Enclosure Ground Bar .....	22
Figure 3-13; Conduit Location .....	23
Figure 3-14; Coaxial Connectors .....	23
Figure 3-15; Alpha Cell Battery Date Code .....	25
Figure 3-16; In-Line Fuse Link Mounting .....	25
Figure 3-17; Vertically Mounted Battery Post .....	26
Figure 3-18; Battery Installation Arrangement .....	27
Figure 3-19; Wiring Diagram for two 36V Battery Strings — PN3 Enclosure .....	28
Figure 3-20; Wiring Diagram for two 48V Battery Strings — PN3 Enclosure .....	29
Figure 3-21; Wiring Diagram for three 36V Battery Strings — PN4 Enclosure .....	30
Figure 3-22; Wiring Diagram for three 48V Battery Strings — PN4 Enclosure .....	31
Figure 3-23; Battery Temperature Sensor Mounting Location .....	32
Figure 4-1; Security Bolt Location .....	33
Figure 4-2; Black Clip in Place .....	33
Figure 4-3; Retaining Washer .....	33
Figure 4-4; Security Key (Part Number 647-089-10) .....	33
Figure 4-5; Battery Interface Unit .....	34
Figure 4-6; BBX 70A (BBX-F12) .....	34
Figure 4-7; BBX 100A (BBX-F18) .....	34
Figure 4-8; MTS (Showing 100A and 60A boxes) .....	35
Figure 4-9; FBX-60A .....	35
Figure 4-10; IPP for Three Power Supplies .....	35
Figure 4-11; IPP for Two Power Supplies .....	35
Figure 4-12; IPP for One Power Supply .....	35
Figure 4-13; Breaker Duplex Option (BDO) for One Power Supply .....	35
Figure 4-14; Cooling Fan Panel .....	36
Figure 4-15; Panel is Installed in Top Rear of Enclosure .....	36
Figure 4-16; Cooling Fan Plugged into Power Supply and SPI .....	36
Figure 4-17; LA-P+ Installed in BDO .....	37
Figure 4-18; Location of LED on LA-P+ .....	37
Figure 5-1; Single-Wide Pad, for CE8/9 or PN 3/4 .....	39
Figure 5-2; Double-Wide Pad, for CE8/9 or PN 3/4 .....	40
Figure 5-3; Double-Wide Pad, for CE 3x2/9x2 and CE8/9 or PN 3/4 .....	41

# Product Safety

## Important Safety Instructions Used Throughout this Manual



To reduce the risk of injury or death caused by electrical shock, explosion of fuel or moving parts; and to ensure the continued safe operation of this product, the following symbols have been placed throughout this manual. Where these symbols appear, use extra care and attention.



### Dangerous Voltage

This symbol indicates a “dangerous voltage” may exist in this area of the product. Use caution whenever working in the area to prevent electrical shock.



### Inhalation Hazard - Don't Breathe Vapors

This symbol indicates an “inhalation hazard” may exist in this area of the product. Use caution whenever working in the area to prevent possible inhalation of harmful (fuel or exhaust) vapors.



### No Matches or Open Flames

This symbol indicates a “fire or explosive hazard” may exist in this area of the product. Use caution whenever working in the area to prevent possible combustion of fuel vapors.



### Mechanical or Moving Parts Hazard

This symbol indicates an “mechanical or moving parts hazard” may exist in this area of the product. Use caution whenever working in the area to prevent possible injury to the operator or service personnel.

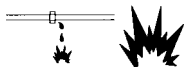

### Leak Hazard

This symbol indicates a “leak hazard” may exist in this area of the product. Use caution whenever working in this area to prevent and correct any leaks detected.



### Attention

This symbol indicates important installation, operation or maintenance instructions. Always follow these instructions closely.

### ***Save these instructions for future reference.***



**NOTE:** Alpha Technologies' products are subject to change through continual improvement processes. Therefore, specifications and/or design layouts may vary slightly from descriptions included in this manual. Updates to the manual will be issued when changes affect form, fit or function.

## Important Notes About Installation

- The system must be installed only by qualified service personnel.
- Always consult local codes for mounting pad requirements.
- Consult local utility codes for additional cabinet grounding and utility requirements.
- Consult the local gas company for correct meter type and riser location.
- Whenever possible, it is best that the enclosure be installed above flood zones .
- Precast Mounting Pads may either be purchased from Alpha or poured in place. The pad must be capable of holding 1,000 lbs (minimum). Rebar may be placed in a crosshatch pattern for pad reinforcement, as needed.
- If the pad is to be located in an area with a deep frost line or unstable soil, concrete pylon footings (4" diameter X 4' deep, or 1' deeper than the regional frost line) can be placed below the concrete pad, in front of and below the (4) mounting features.
- The top of the pad must be above grade to reduce the buildup of debris around the base of the cabinet.
- Adequate space must be allowed for Cable TV input/output conduit; plant grounding electrode conductor(s); RF cable entrance via (1) 4", (2) 3" or (3) 2 1/2" rigid conduit sweep(s) with 2' bend radius (minimum); and fiber optic cable entrance (refer to fiber manufacturer's specification for minimum bend radius requirements).
- Prior to pouring concrete, any wire running through the pad must have a thermal expansion jacket (i.e., PVC) to prevent cracking of the concrete during lightning strikes.
- Alpha Technologies is not responsible for broken welds or other damage to the cabinet caused by improper installation.
- A 25+ year vapor barrier must be used between the concrete pad and the base of the enclosure to further inhibit the ingress of moisture. Alpha Technologies is not responsible for water damage or moisture damage resulting from improper installation.
- Concrete filled, 6" diameter steel posts (or equivalent) can be placed at the corners of the pad to reduce exposure to accidental traffic damage.
- All dimensions are given in inches.
- For further information regarding this installation, contact Alpha Technologies or your nearest Alpha representative.

# Contacting Alpha Technologies

## Product Information, Customer Service or Technical Support

- For general product information and customer service 7:00 AM to 5:00 PM Pacific Time, call:

1-800-863-3930

- To obtain complete technical support 7:00 AM to 5:00 PM Pacific Time, or for after-hours emergency support, call:

1-800-863-3364

(7 days per week, 24 hours a day)

## Product Returns

### Returns for Repair

In the event of a need for repair, Alpha products may be returned by either method listed below:

- Download the necessary forms directly from Alpha's Web site, under "Support":

[www.alpha.com/support/](http://www.alpha.com/support/)

*OR*

- Call (800) 322-5742 for assistance.

### Returns for Credit

Credit return requests must be initiated with a phone call. Call: (800) 322-5742.

## 1.1 Introduction

To ensure operator safety:

- Enclosures must be installed only by qualified personnel and in accordance with all applicable electrical codes.
- Use eye protection whenever working with batteries.
- Use only sealed, lead-acid type batteries (gelled-electrolyte or equivalent, 65 Ah min.)

### Unpacking and Inspection:

Carefully remove the enclosure from the shipping container. Verify that:

- The correct unit was shipped (either Alpha PN-3 or PN-4 enclosure).
- Ordered options have been included. (Refer to packing label details located on wooden pallet. See figure 1-2)



**NOTE:** Batteries are shipped separately.



Figure 1-1; Enclosure as it Arrives from Alpha



Figure 1-2; Packing Label Location

Inspect the contents. If items are damaged or missing, contact Alpha Technologies and the shipping company immediately. Most shipping companies have only a short claim period.

# 1. Introduction

## 1.2 PN-3 and PN-4 Povernode Enclosure

Alpha's PN Series Power Module enclosures offer complete flexibility and modular expandability for Cable TV powering applications. The Modular Tray system simplifies installation while allowing for future expansion or reconfiguration. The PN Series is designed to accommodate current system power requirements while allowing the cost-effective addition of power capacity, as well as enhanced reliability options, when new services are integrated. Excellent for either distributed or centralized powering architectures, PN Series enclosures are available to accommodate multiple power supplies, battery strings and/or natural gas or propane generators

Figure 1-3; PN-3 Specifications

**Dimensions:** 26" W x 44" H x 24" D  
**Power Supply Capacity:** Up to three power supplies (6kW)  
**Weight:** 100-170 lbs ( depending on options)  
**Material:** Aluminum, .080-.125 inches

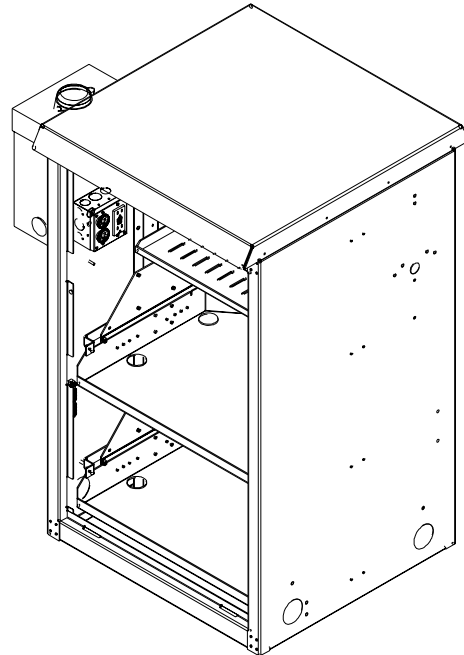
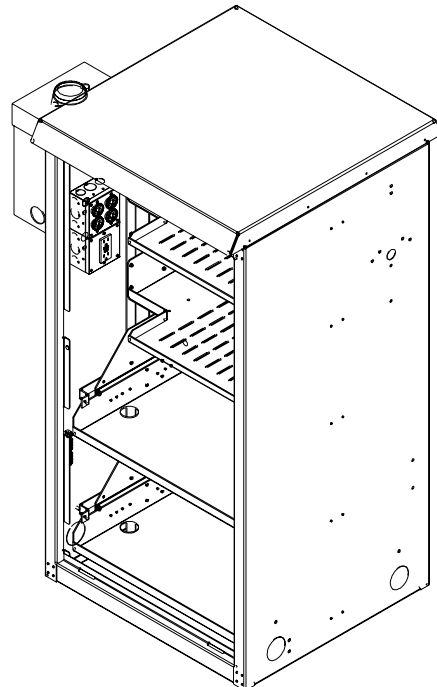

Figure 1-4; PN-4 Specifications

**Dimensions:** 26" W x 52" H x 24" D  
**Power Supply Capacity:** Up to three power supplies (6kW)  
**Weight:** 110-180 lbs ( depending on options)  
**Material:** Aluminum, .080-.125 inches



## 2. Pre-Installation

### 2.1 Site Preparation

The site must be planned so that the enclosure will receive good air flow. If possible, in areas of extreme heat, it is best to position the enclosure so that it will be shaded from the afternoon sun. In areas of prevailing winds, it is best that the enclosure be located so that the sides of the cabinet face the winds instead of the doors. This will greatly reduce the buildup of sand or snow against the enclosure's air vents.

In areas of potential flooding, the geographical site and concrete pad must be located above the flood plain. Pedestals are available to raise the Power Node enclosures above expected snow and water levels.

The enclosure must be placed where it will be free of obstructions, allowing easy access to the doors for service or equipment access. For ventilation and maintenance, allow a minimum space of 36 inches in the front and 36 inches in the rear, between the enclosure and other solid structures.

Place the enclosure well away from ground level sources of forced water, such as underground sprinkler systems and direct roadway splash.

The concrete pad drawing is provided in the Pre-Installation Section of this manual contains all of the required mounting details, including electrical service and cable plant entrances.

The vapor barrier material (such as 30 lb. felt, neoprene pond liner, or heavy grade tar paper) must initially extend at least 6" in all directions around the perimeter of the enclosure and be trimmed closer to the enclosure, using the appropriate utility knife or cutting tool.



**WARNING:** Never transport the unit with batteries installed. Batteries must ONLY be installed after the unit is transported to the site and secured to the pad. Transporting the unit with batteries installed may cause a short circuit, fire, explosion, and/or damage to the battery pack, enclosure and installed equipment. Damage caused by improper shipping or transporting a unit with batteries installed is not covered under warranty.

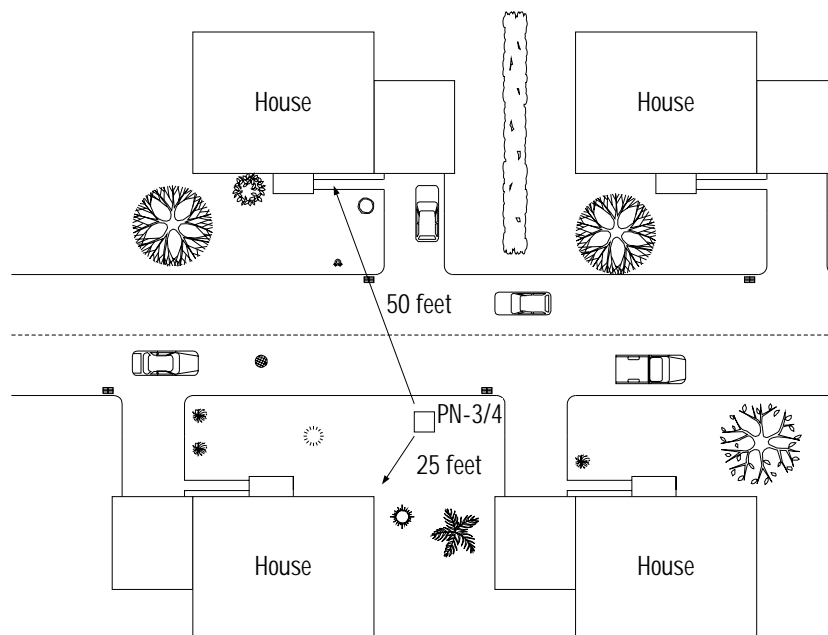

Figure 2-1; Suggested Site Selection, PN-3 and PN-4

## 2. Pre-Installation

### 2.2 Concrete Pad Preparation

Pads can either be poured on site, or precast by Alpha Technologies. Available concrete pad configurations and part numbers can be found in section 5, "Alpha Part Numbers".

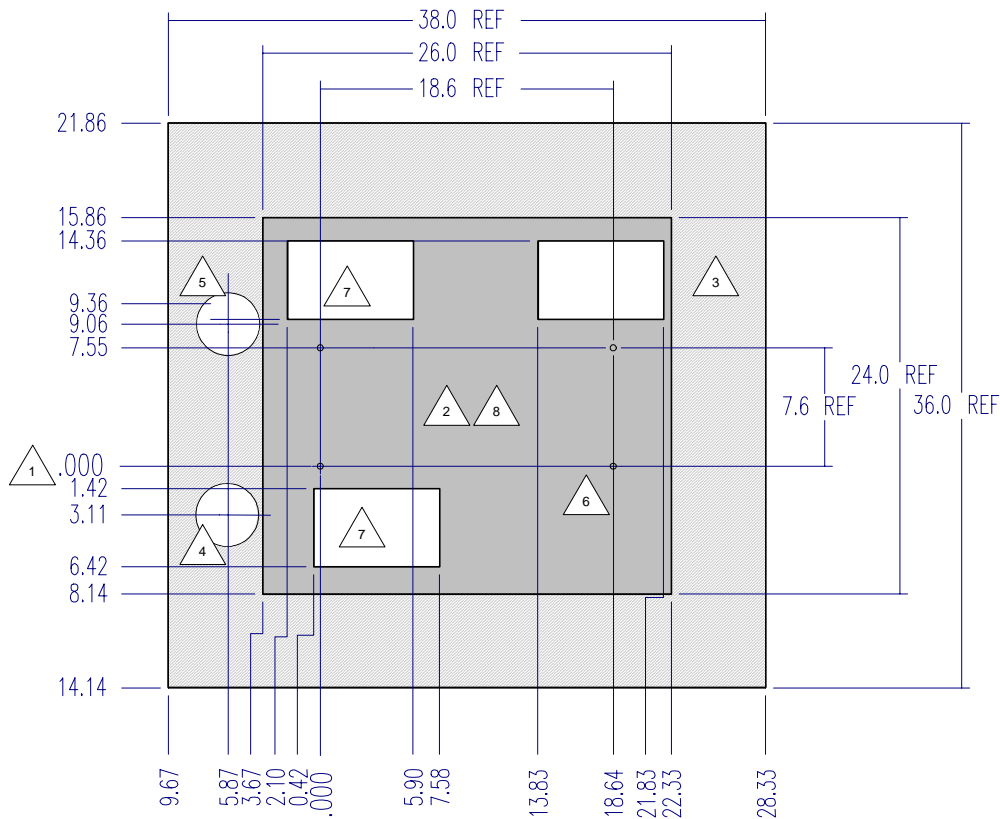

Figure 2-2; Single-Wide Concrete Pad for PN-3 and PN-4

- 1 All dimensions shown in inches. Mounting holes and sweeps indexed from this position.
- 2 Indicates PN-3 and PN-4 pedestal enclosure mating surface.
- 3 Alpha standard; recommended distance (6" minimum) between edge of pad and cabinet.
- 4 Four inch diameter hole for AC power IN (non-metered installation).
- 5 Four inch diameter opening for DC Output cable and Status Monitoring harness.
- 6 All mounting hardware must be stainless, galvanized, or better to prevent corrosion.
- 7 5" x 8" rectangular cutout (2 places), open area for all internal connections including: generator power and/or coax cable conduit sweeps.
- 8 A 25+ year continuous vapor barrier must be used between the enclosure and the pad to prevent moisture ingress and possible corrosion caused by metal to concrete contact. The vapor barrier material (such as 30 lb felt, neoprene pond liner, or heavy grade tar paper) must be initially extended at least 6" in all directions around the perimeter of the enclosure. After the enclosure is secured to the pad, the material can be cut closer to the enclosure, using the appropriate knife or cutting tool.

2.3 Enclosure Grounding

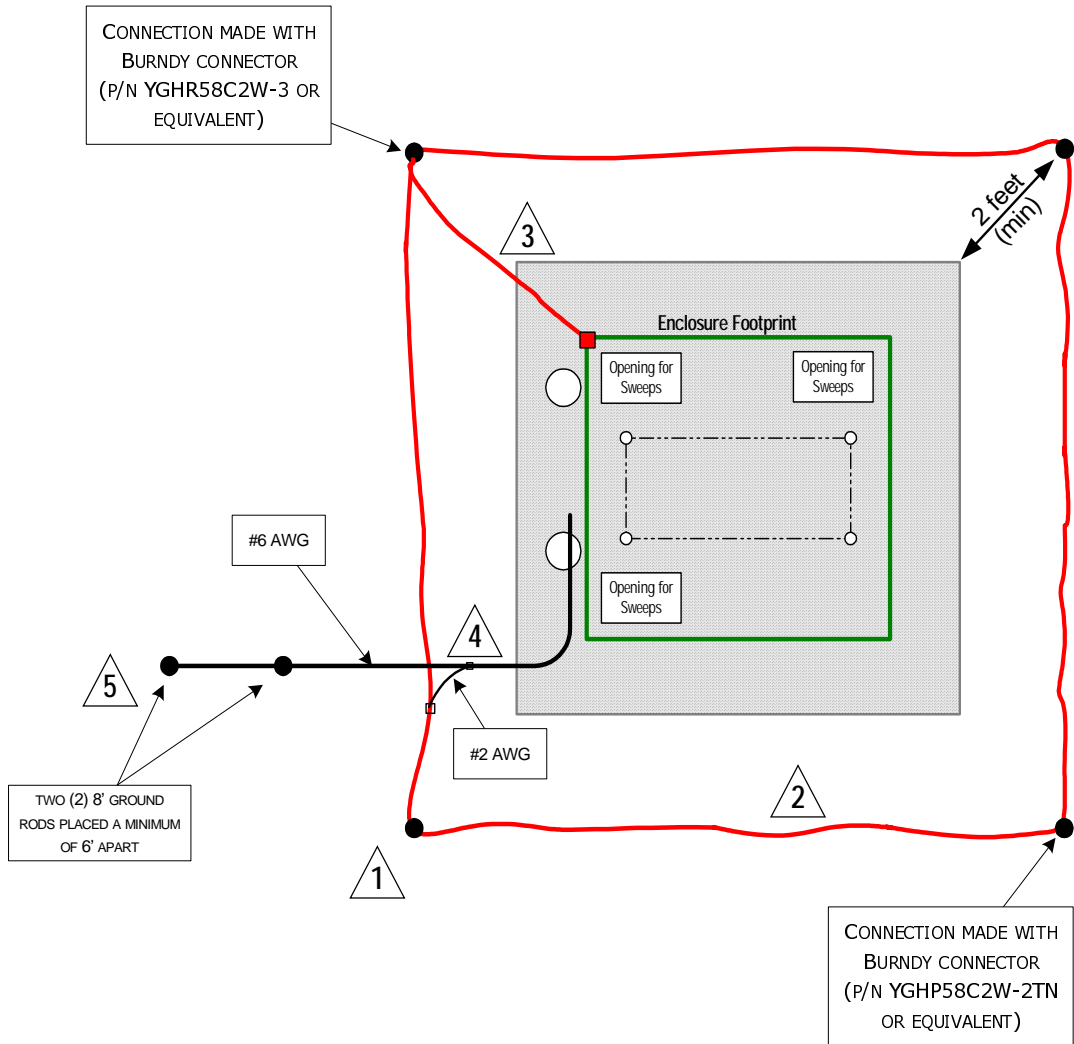

Figure 2-3; Suggested Grounding, PN-3 and PN-4

Lightning Protection (Optional)

- 1 1/2" x 8" copper ground rod, four places, driven about 2 feet (typical) from the corners of the pad.
- 2 #2 bare copper wire loop terminated to each ground rod and buried below grade 2 to 12 inches. Corrosion-proof connections (25+ year life-span) and hardware suitable for direct burial MUST be used
- 3 #2 bare copper wire from loop to the enclosure
- 4 When the electrical supply is a primary service (not a secondary or feeder service) a #2 bare copper wire must be bond the lightning protection loop to the Grounding Electrode Conductor where they are closest.

Service Grounding (required)

- 5 #6 bare copper wire from Service Neutral / Ground Bar with 2 ground rods located 6' apart.

## 2. Pre-Installation

### 2.3 Enclosure Grounding, *continued*

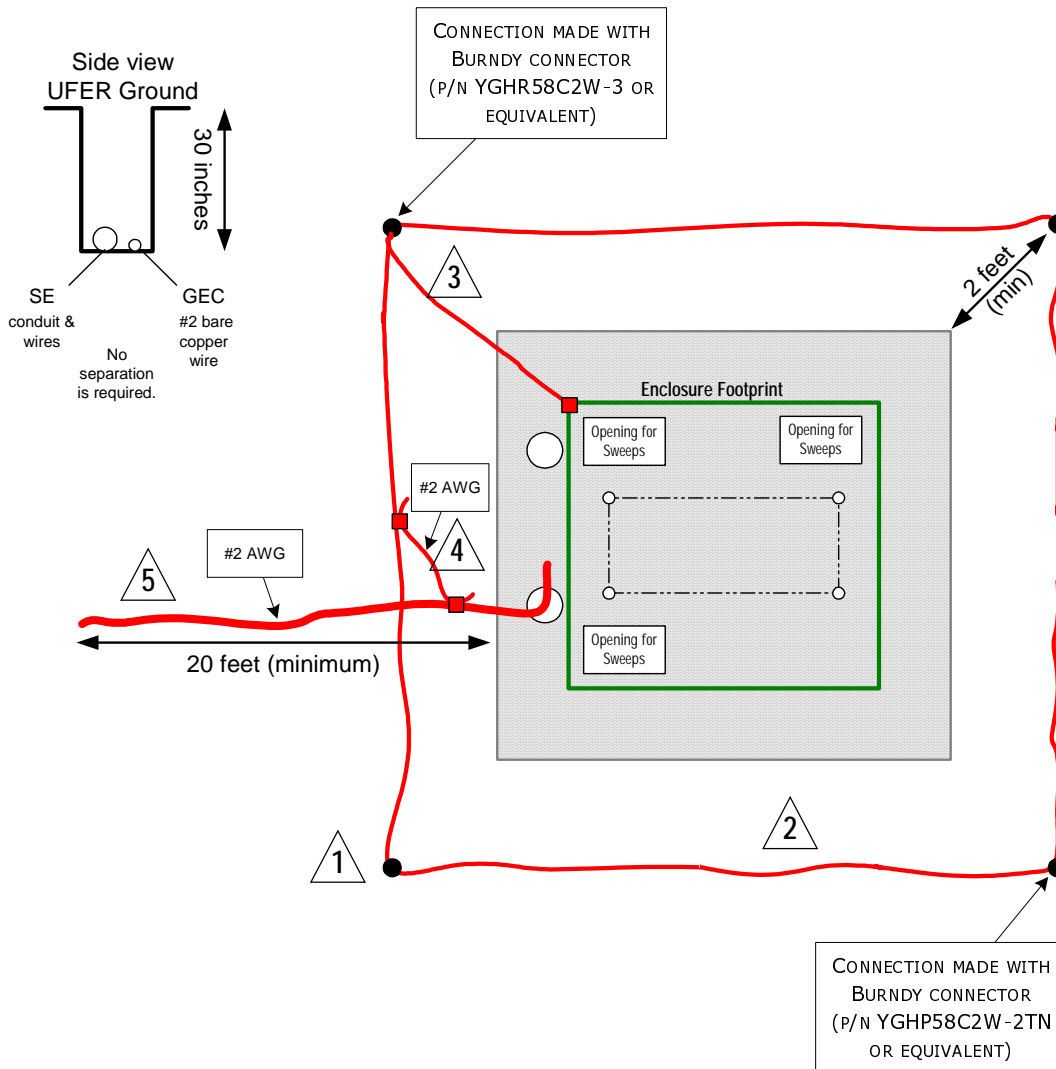

Figure 2-4; Alternate Grounding, PN-3 and PN-4

#### Lightning Protection (Optional)

- 1 1/2" x 8' copper ground rod, four places, driven about 2 feet (typical) from the corners of the pad.
- 2 #2 bare copper wire loop terminated to each ground rod and buried below grade 2 to 12 inches. Corrosion-proof connections (25+ year life-span) and hardware suitable for direct burial MUST be used.
- 3 #2 bare copper wire from loop to the enclosure
- 4 When the electrical supply is a primary service (not a secondary or feeder service) a #2 bare copper wire must be bonded to the lightning protection loop to the Grounding Electrode Conductor where they are closest.

#### Service Grounding (required)

- 5 #2 bare copper wire from Service Neutral / Ground Bar down 30 inches and out 20 feet beyond the pad edge. This is often called a UFER ground (Ground Ring in the NEC).

## 3.1 Transportation and Lifting

The PN-3 or PN-4 cabinet as shipped weighs approximately 100-150 lbs. A safe means of transportation to the site and a safe procedure for unloading the enclosure is necessary. Do not transport or lift with a device that may not be able to bear the unit's weight, and do not place the unit upon a surface that will not be able to fully support it.



**NOTE:** Enclosure must always remain in the upright position during the shipping, storage and installation process. Damage may result from enclosure being shipped or stored on its side.



**NOTE:** Electronic modules, batteries or other components must not be installed until the enclosure is securely set in place at its permanent location.

## 3.2 Enclosure Mounting Procedure

The enclosure bolts directly to the concrete pad. Mounting holes are provided in the base of the internal enclosure rack to accommodate the pad's 3/8" stainless or galvanized anchor bolts.

1. Place vapor barrier material on pad and make cutouts for anchoring hardware and other openings as necessary. A 25+ year vapor barrier **MUST** be used between the concrete and enclosure base to inhibit moisture ingress and to prevent corrosion caused by concrete-to-metal contact.
2. With no less than two field personnel lifting the enclosure, position it above the concrete pad and slowly lower it into position over the pad's 3/8" anchor bolts.
3. Secure the enclosure using stainless, galvanized (or better) flat washers, lock washers and 3/8" nuts at each mounting bolt.



**NOTE:** Enclosures must be mounted flush with a smooth surface. If the concrete pad is uneven or has bumps, cracks or other imperfections, the installer is responsible for correcting these defects prior to installing the enclosure.

4. Install electronic modules and batteries at this time.

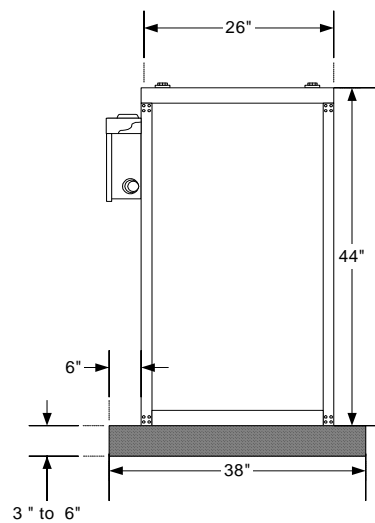

Figure 3-1; PN-3 Mounted to the Prepared Pad

## 3. Installation

### 3.3 Utility Powering

The XM2 Power Supplies are powered by either 120VAC or 240VAC (depending upon the model), attached to an external service entrance. The size of the service conductors must be based upon the actual size of the utility service and be in accordance with applicable electrical code requirements.

The utility conduit may be placed in one of two locations, depending upon the utility service entrance requirements. Note the optional conduit location for use with meter base and the standard location for entry directly to the load center.

Proper grounding is critical. The enclosure **MUST** have a hard-wired ground to the service entrance. A qualified electrician will need to verify that grounding is in compliance with applicable electrical codes. (Refer to section 2.3, "Enclosure Grounding").



**NOTE:** All applicable codes must be adhered to when installing a system, pouring concrete, or placing a preformed pad. These codes supersede any procedures outlined in this document.



**NOTE:** All mounting hardware must be *stainless* or *galvanized*, depending on local environmental conditions. Use of improper hardware may cause corrosion, which is not covered under warranty.



**NOTE:** Soil conditions vary and may affect the integrity of the pad. Alpha Technologies recommends that proper steps be taken to ensure that the soil supporting the pad is stable. Improper installation of the pad may cause uneven settling or cracking, which is not covered under warranty.

Both standard and EUSERC style meter bases are available for some configurations as illustrated in the following figures. Consult Alpha Technologies or your local representative regarding compatibility with your specific application.



**CAUTION:** The following utility powering procedures must be performed only by qualified service personnel and in compliance with local electrical codes.

Verify electrical codes prior to installation. Codes may vary and contain specific conduit and wire sizes for connection to the service entrance.

Connection to utility power must be approved by the local utility before installing the power supply.

The enclosure is equipped with a Square D, rainproof service entrance (SUSE rated). The service entrance is equipped with a circuit breaker for a 120/240VAC, split phase, 3-wire w/GND source.

#### Materials Required:

- 1" diameter conduit (or larger)- PVC or Galvanized Steel (threaded)
- #6 AWG - Red /stranded insulated wire
- #6 AWG - Black / stranded insulated wire
- #6 AWG - White / stranded insulated wire
- #2 AWG or larger - Stranded copper ground wire

## 3.3 Utility Powering, *continued*

### 3.3.1 Connection Procedure for the BBX-100A-8POS Service Disconnect:

1. Locate the service entrance panel on the enclosure (exterior). Remove the cover to access the circuit breaker assembly. If this service panel is to be used as the primary service entrance, neutral must be bonded to ground by installing the green ground screw (provided) in the hole in the neutral bus.
2. Remove the knockout located at the base of the service entrance to accept the conduit.
3. Install the conduit nipple into the service entrance via the knockout and secure with the appropriate threaded conduit locknut.
4. Locate the two screw terminals (L1 and L2) on the bottom of the input circuit breaker.
5. Connect one of the incoming Black #6 AWG wires to L1 (left terminal). Connect the remaining Black (or Red) #6 AWG wire to L2 (right terminal). NOTE: If the wire at L2 is Black, Mark it with red tape (or label).
6. Connect the #6 AWG White wire to the neutral (N) bus lug located to the top right of the circuit breaker assembly.
7. Connect the #6 Bare solid or stranded for Grounding Electrode Conductor (Earth Ground) to the ground and neutral bus located to the right side of the circuit breaker assembly.
8. Notify the electrical inspector to approve the service entrance wiring. Once approved, contact the local power utility for electrical service.

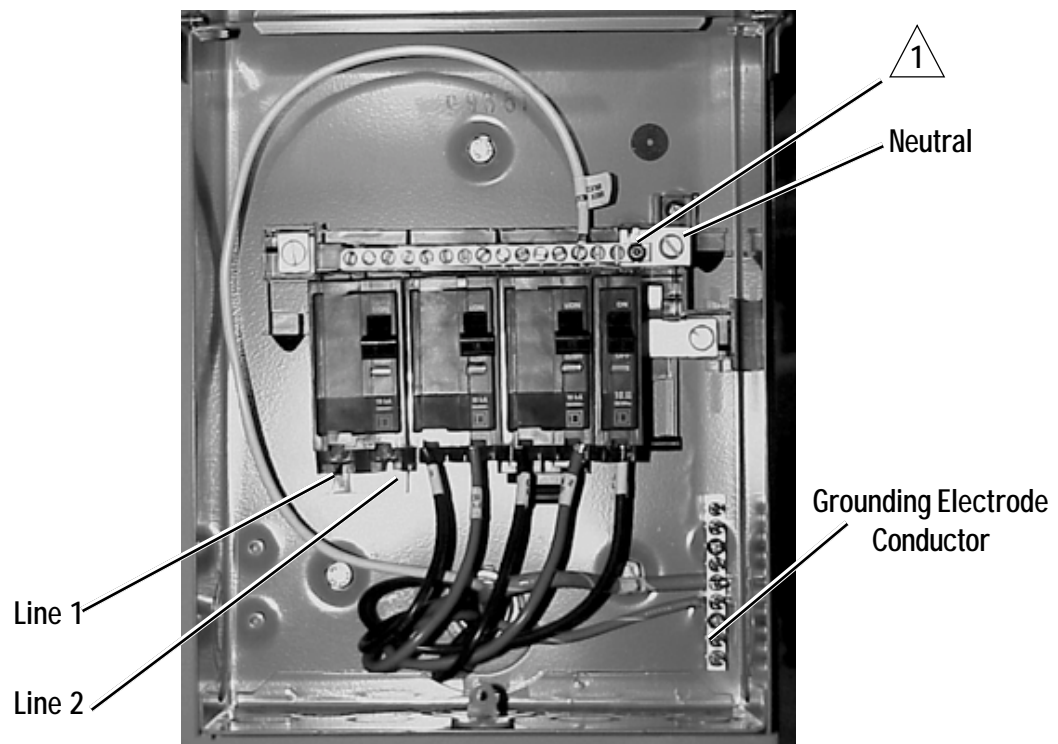

Figure 3-2; BBX-100A-8POS Service Disconnect



Bond made by bonding screw only if no other service panel is used. (Must be installed on site only if this is the primary service entrance.)

# 3. Installation

## 3.3 Utility Powering, *continued*

### 3.3.2 Connection Procedure for the BBX-70A Service Disconnect:

1. Locate the service entrance panel on the enclosure (exterior). Remove the cover to access the circuit breaker assembly. If this service panel is to be used as the primary service entrance, neutral must be bonded to ground by installing the green ground screw (provided) in the hole in the neutral bus.
2. Remove the knockout located at the base of the service entrance to accept the conduit.
3. Install the conduit nipple into the service entrance via the knockout and secure with the appropriate threaded conduit locknut.
4. Locate the two screw terminals (L1 and L2) on the top of the input circuit breaker.
5. Connect one of the incoming Black #6 AWG wires to L1 (left terminal). Connect the remaining Black (or Red) #6 AWG wire to L2 (right terminal). NOTE: If the wire at L2 is Black, mark it with red tape (or label).
6. Connect the #6 AWG White wire to the neutral (N) bus lug located to the top right of the circuit breaker assembly.
7. Connect the #6 Bare solid or stranded for Grounding Electrode Conductor (Earth Ground) to the ground and neutral bus located to the right side of the circuit breaker assembly.
8. Notify the electrical inspector to approve the service entrance wiring. Once approved, contact the local power utility for electrical service.

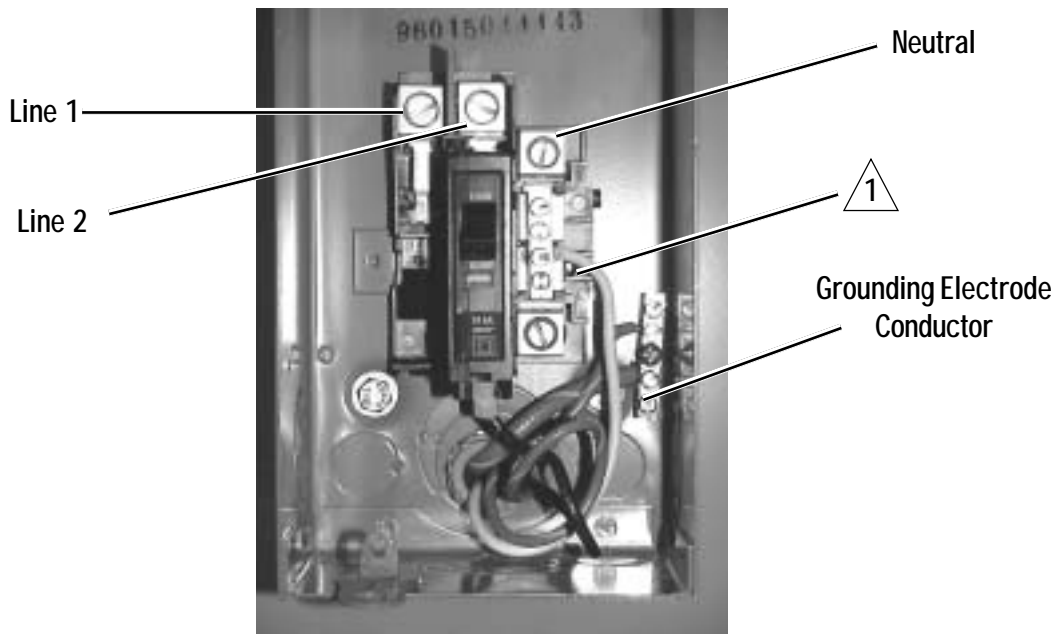

Figure 3-3; BBX-70A Service Disconnect



Bond made by bonding screw only if no other service panel is used. (Must be installed on site only if this is the primary service entrance.)

## 3.3.3 Sample Input Power Panels

For more information on available models of the Input Power Panel, refer to "PN Series Options", section 4.4.

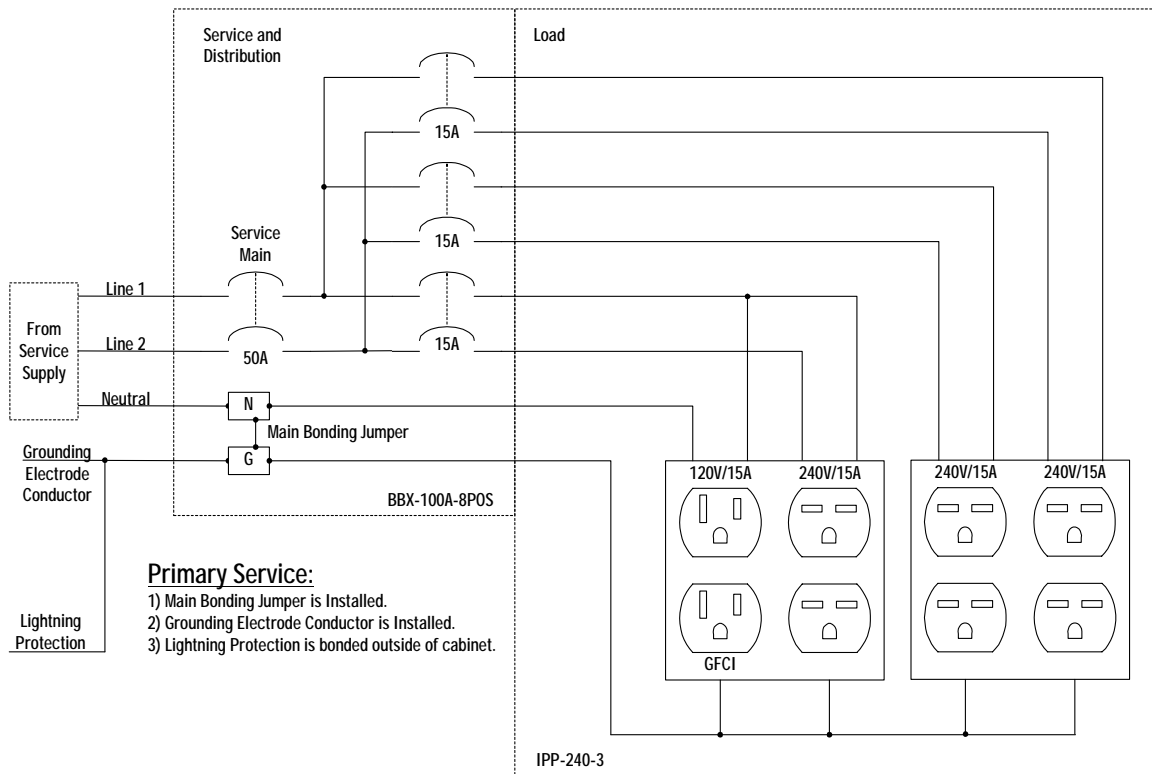

Figure 3-4; Schematic: Primary Service BBX-100A-8POS with IPP-240-3

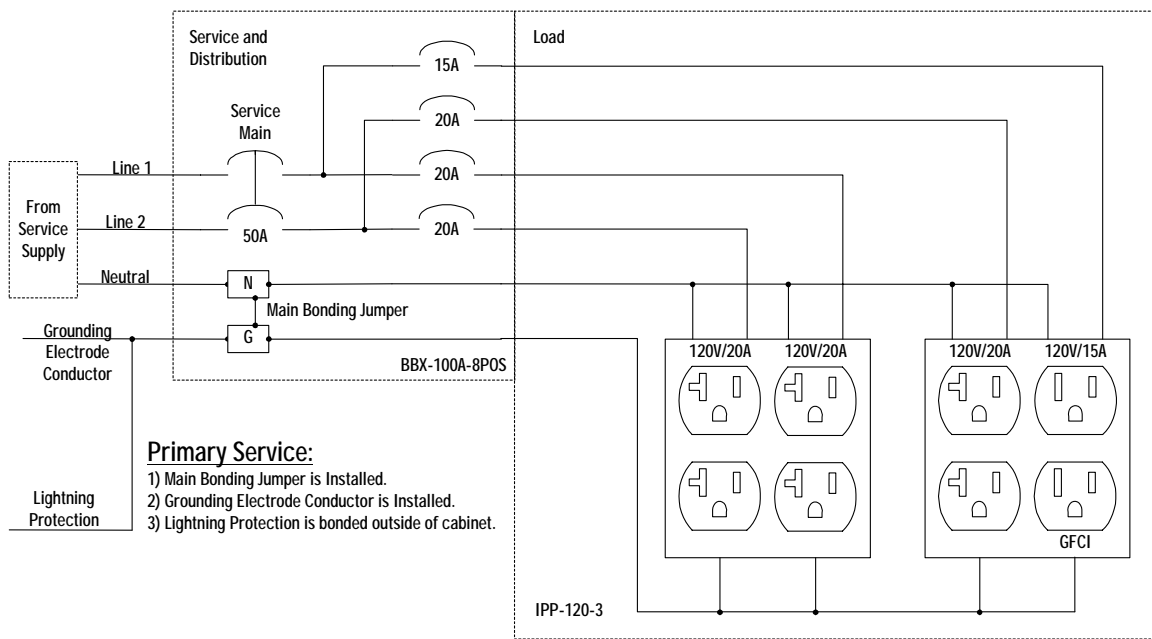

Figure 3-5; Schematic: Primary Service BBX-100A-8POS with IPP-120-3

# 3. Installation

## 3.3.3 Sample Input Power Panels, *continued*

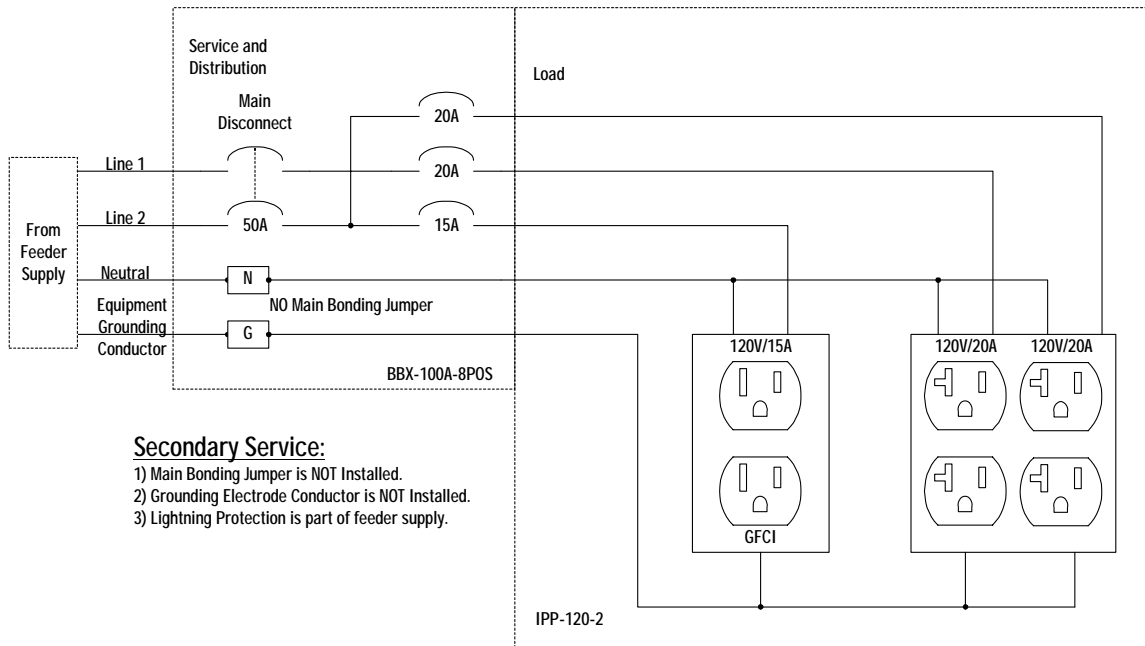

Figure 3-6; Schematic: Secondary Service BBX-100A-8POS with IPP-120-2

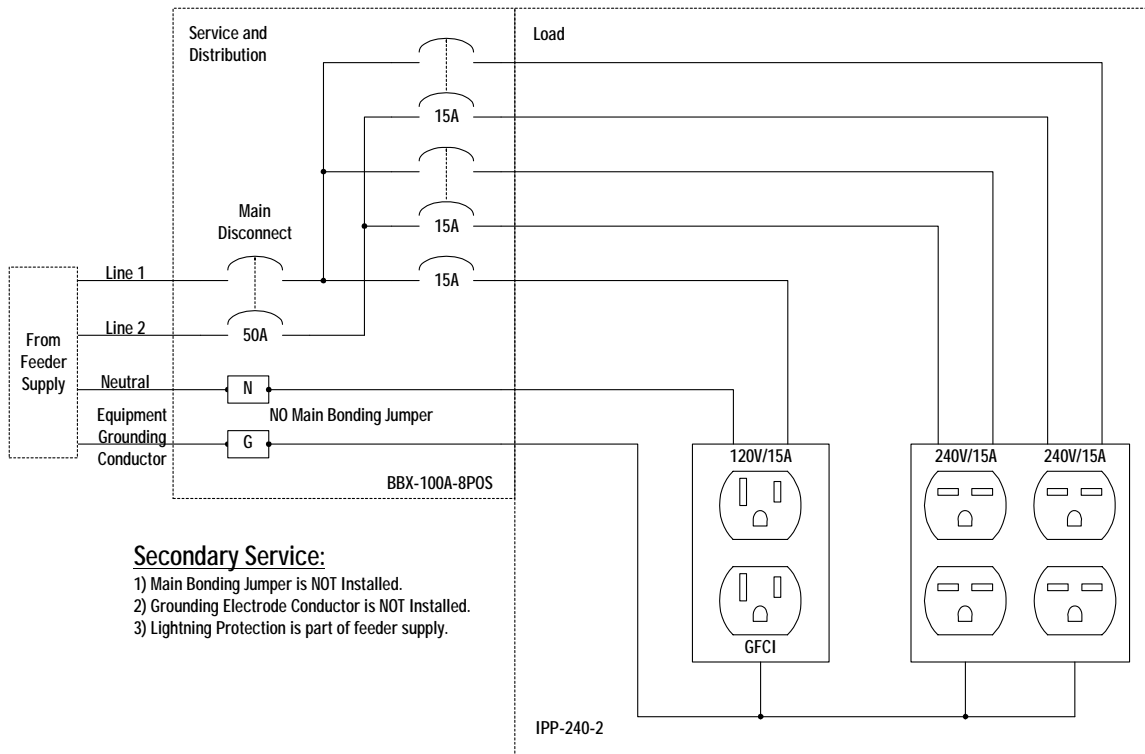

Figure 3-7; Schematic: Secondary Service BBX-100A-8POS with IPP-240-2

## 3.3.3 Sample Input Power Panels, *continued*

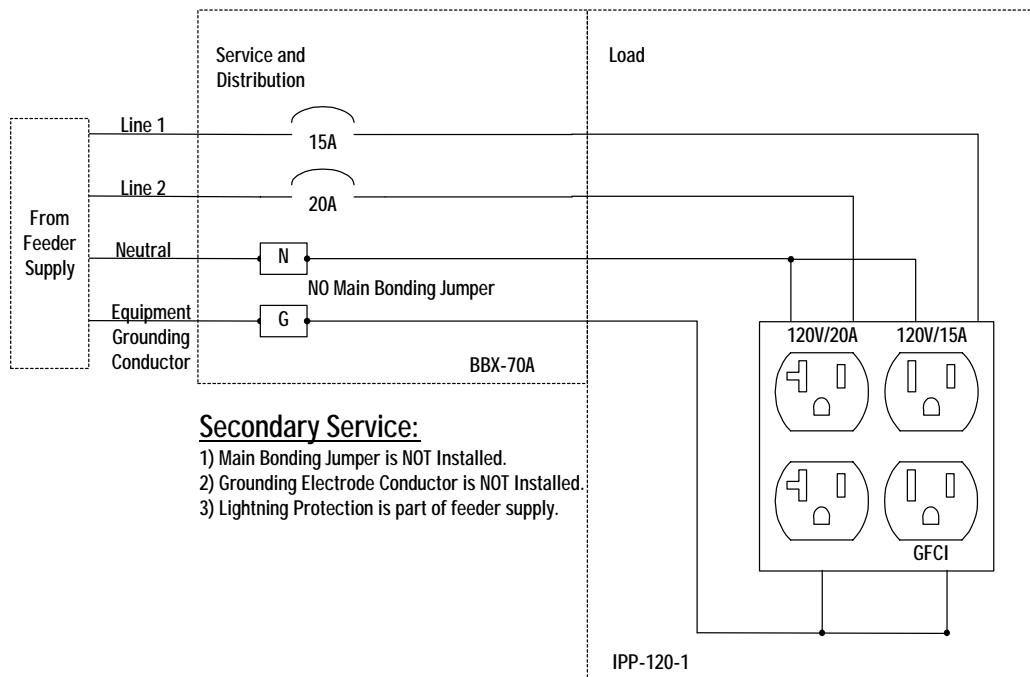

Figure 3-8; Schematic: Secondary Service BBX-70A with IPP-120-1

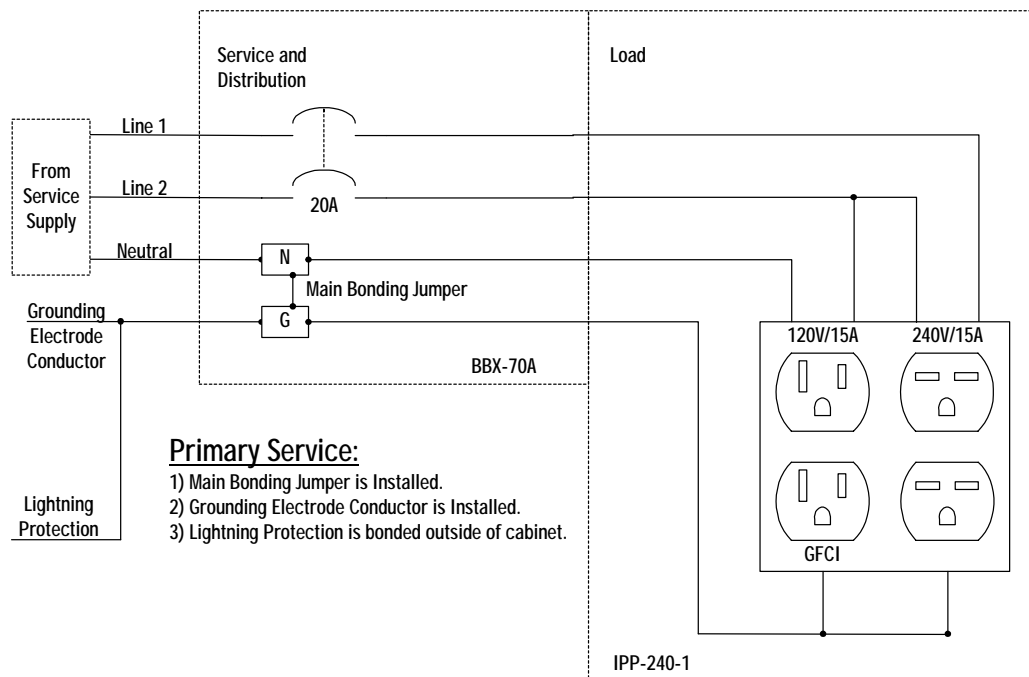

Figure 3-9; Schematic: Primary Service BBX-70A with IPP-240-1

## 3. Installation

### 3.4 Coaxial Cable to Service Power Inserter (SPI) Installation

#### 3.4.1 SPI to Ground Bar Connection Procedure

Tools List:

1" Socket (3/8" drive)  
3/8" Ratchet  
#2 Phillips Screwdriver  
Zip Tie Gun

- 1). Install SPI by tightening the attached coaxial connector to the equipment tray.



Figure 3-10; Connector Fitting in Rear of Equipment Tray

- 2). Secure SPI ground wire to the SPI with attached screw, and connect to enclosure ground bar.



Figure 3-11; Location of SPI in Equipment Tray

- 3). Terminate stripped end of wire at enclosure ground bar.



Figure 3-12; SPI Ground Wire Connected to Enclosure Ground Bar

## 3.4.2 Conduit Placement

Conduit location is in the back of the enclosure, on the right side. (Location is specified on concrete pad.)



Figure 3-13; Conduit Location



Figure 3-14; Coaxial Connectors

# 3. Installation

## 3.5 Battery Installation

### 3.5.1 Battery Safety Notes

#### Electrical Hazards

Battery systems represent a risk of electrical shock and high short circuit currents. The following precautions must be observed when maintaining batteries:

- Remove all personal metal objects (watches, rings, etc.)
- Use insulated tools.
- Wear eye protection and rubber gloves.
- Observe circuit polarities.
- Do not make or break live circuits.
- Do not lay metal tools and hardware on top of the batteries.

The battery is enclosed in cabinets with limited access. Again, extreme caution must be exercised when maintaining and collecting data on the battery system.

#### Disposal

- Lead acid batteries are to be recycled. Batteries contain lead and dilute sulfuric acid. Dispose of in accordance with Federal, State, and local regulations. Do not dispose of in a landfill, lake or other unauthorized location.

#### Chemical Hazards

- Any gelled or liquid emissions from a battery is electrolyte, and contains dilute sulfuric acid which is harmful to the skin and eyes; is electrically conductive; and is corrosive.
- If electrolyte contacts the skin, wash immediately and thoroughly with water. If electrolyte enters the eyes, wash thoroughly for 10 minutes with clean water or a special neutralizing eye wash solution and seek immediate medical attention.
- Neutralize any spilled electrolyte with the special solutions contained in a "spill kit" or with a solution of 1 lb. bicarbonate of soda to 1 gallon of water.

#### Fire, Explosion, and Heat Hazards

- Lead acid batteries can contain an explosive mixture of hydrogen gas which can vent under overcharging conditions.
- Do not smoke or introduce sparks in the vicinity of the battery.
- Do not charge batteries in a sealed container. The individual batteries must have 0.5 inches of space between them to allow for convection cooling. If contained, assure the container or cabinet and room have adequate ventilation to prevent an accumulation of potentially vented gas.

## 3.5.2 Battery Identification

Each battery contains a DATE CODE usually located near the positive (+) terminal of the battery. This date code must be recorded in the maintenance log (*MAINTENANCE* manual). If batteries other than those installed by Alpha are used, consult the battery manufacturers' documentation for date code type and placement.



Figure 3-15; Alpha Cell Battery Date Code

## 3.5.3 Battery Terminal Connections

The accompanying drawings are for *illustrative* purposes only. Various types of batteries with different mounting styles and hardware may be shipped with the system. ALWAYS refer to the battery manufacturer's specifications for correct mounting hardware and torque requirements. During maintenance procedures, refer to the manufacturer's specifications for the maintenance torque requirements.

Mounting hardware requirements may vary with battery manufacturers. Use only the hardware recommended by your particular battery manufacturer.



**NOTE:** Use a corrosion inhibitor (such as NCP-2) on battery terminals.

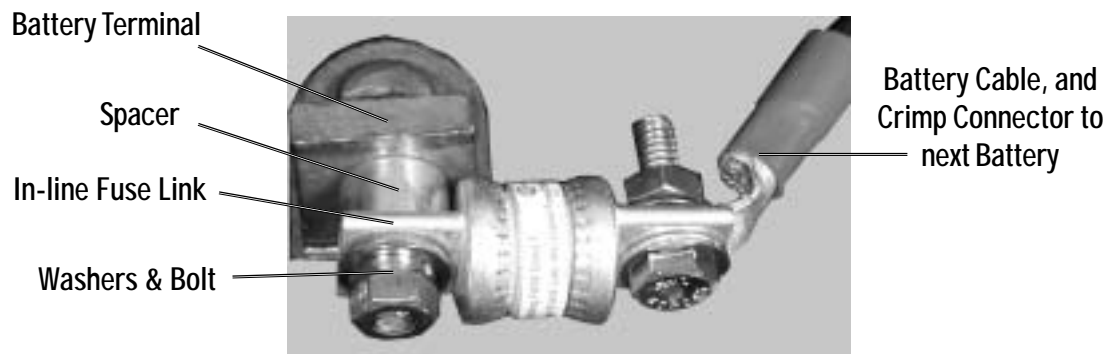

Figure 3-16; In-Line Fuse Link Mounting

## 3. Installation

### 3.5.4 Battery Terminal Assembly Procedure

These illustrations show the Battery Terminal assembly for vertically mounted battery posts. Refer to the battery manufacturers' specifications for tightening torque.

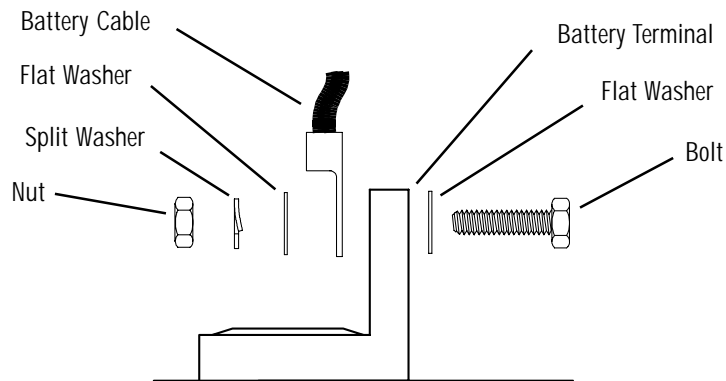

Figure 3-17; Vertically Mounted Battery Post

### 3.5.5 Battery Installation Procedure

1. Place the batteries on their respective shelves as shown in Figure 3-18; "Battery Installation Arrangement" on the next page.
2. Connect the three (or four) batteries in series (negative to positive) to achieve 36VDC (or 48VDC). Route the battery cables inside the vertical rail for connection to the power supply. Terminal connectors must be torqued to approximately 75 inch/pounds at installation and then re-torqued to 50 inch/pounds during routine maintenance.



**NOTE:** The cables are marked with a RED sleeve to indicate the (+) positive battery terminal.

3. Use a voltmeter to verify polarity and DC voltage at the module's battery connector.



**CAUTION:** Whenever making or breaking battery connections, never allow live battery cables to contact the chassis. If necessary, wrap the lugs with electrical tape to prevent arcing and temporarily disconnect one of the leads from the center battery. Check the battery voltages at the connectors leading into the XM power supply.



**NOTE:** Ensure that voltage and polarity are correct before proceeding.

4. Mate the battery connectors to their respective sockets on the power supply module.
5. Number the batteries 1, 2, 3, (4) using labels, masking tape, or china marker. Record each battery's number and date code in the power supply's maintenance log.
6. For installations with multiple battery strings in parallel, each string must be fused. Verify that the enclosure was ordered with a fused Battery Cable Kit (BCK). For replacement fuses, or to add fuses to a BCK without fuses, order the Battery Terminal Fuse Kit, Alpha part number SPB98-645-1.

## 3.5.6 Battery Installation Layout

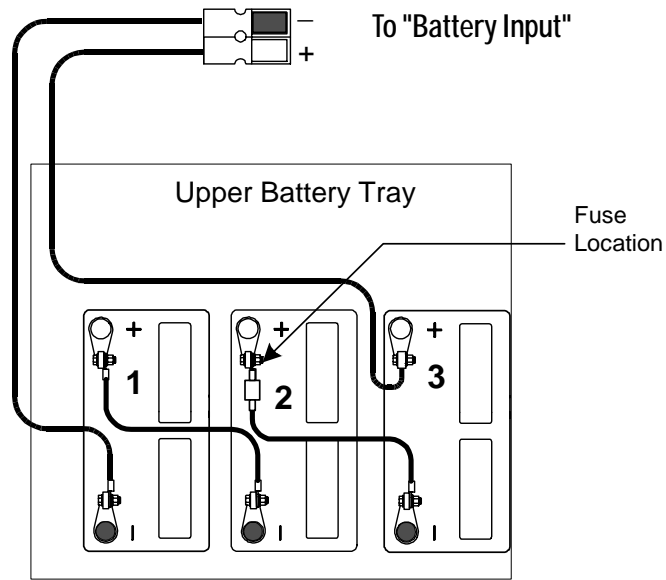

36VDC configuration

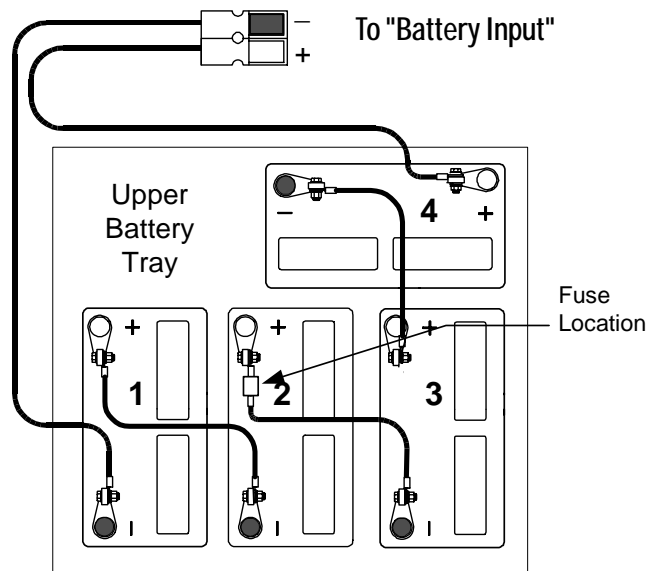

48VDC configuration

Figure 3-18; Battery Installation Arrangement

# 3. Installation

## 3.5.6 Battery Arrangement, Power Supply Connection, *continued*

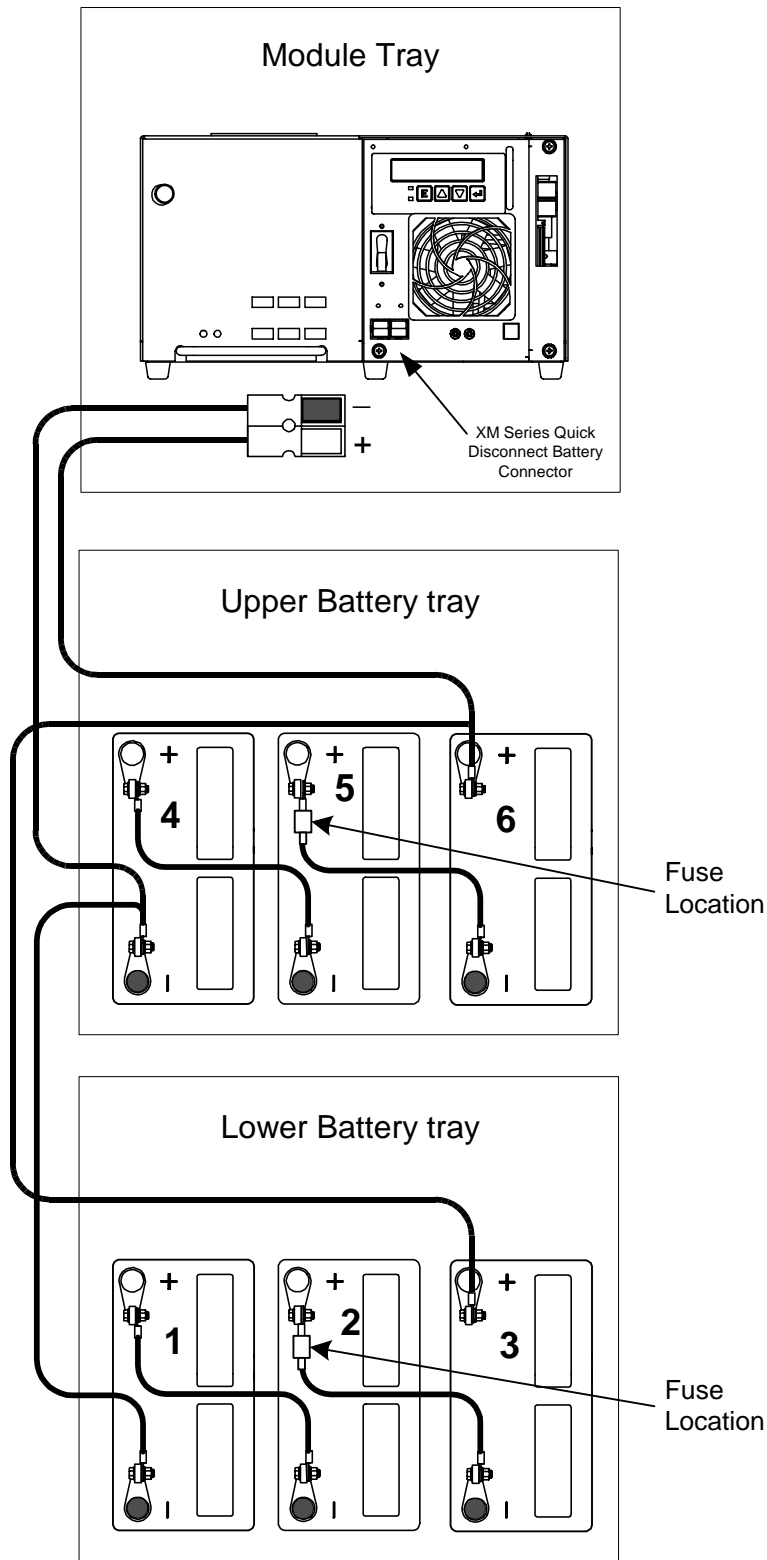

Figure 3-19; Wiring Diagram for two 36V Battery Strings — PN3 Enclosure

## 3.5.6 Battery Arrangement, Power Supply Connection, *continued*

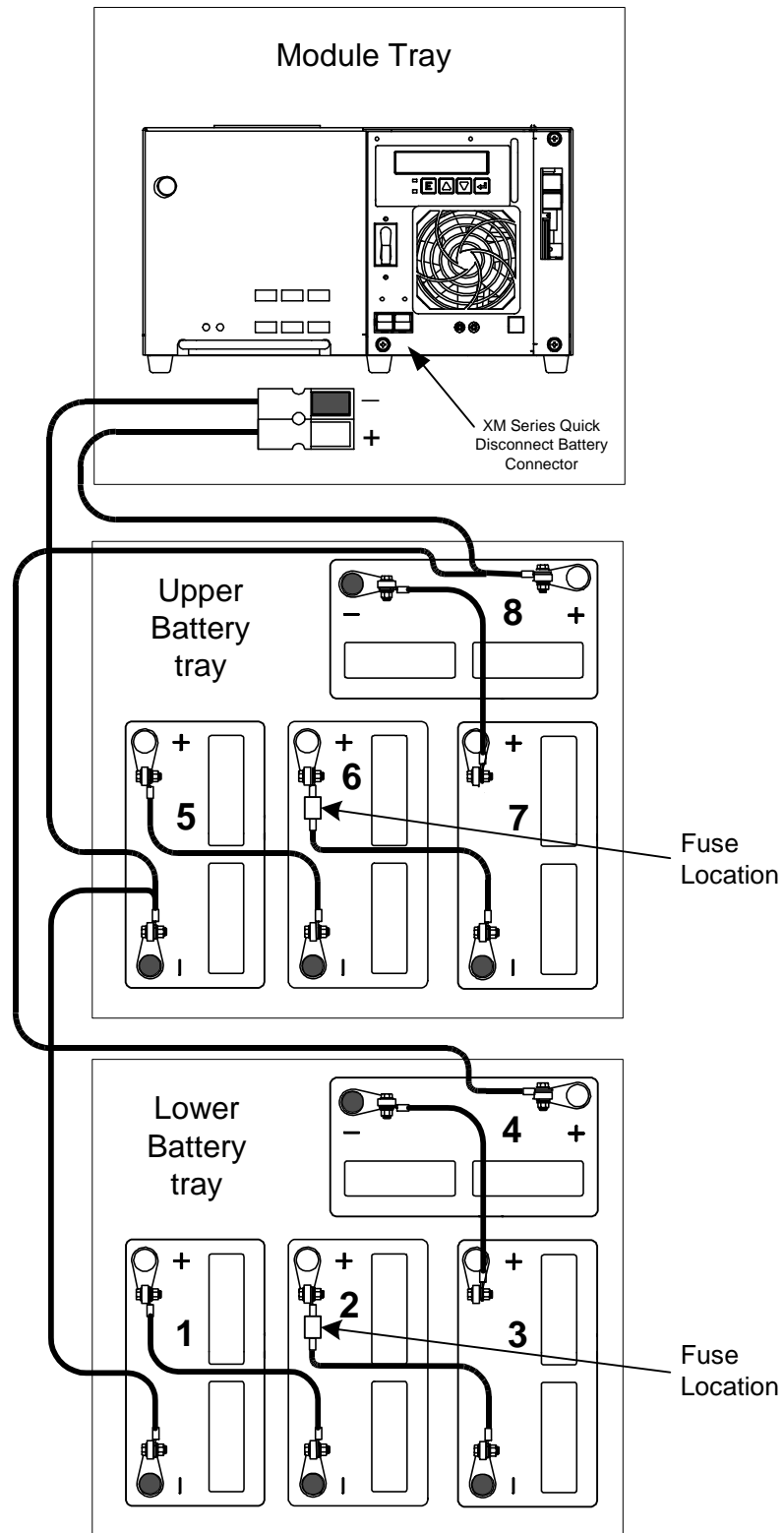

Figure 3-20; Wiring Diagram for two 48V Battery Strings — PN3 Enclosure

# 3. Installation

## 3.5.6 Battery Arrangement, Power Supply Connection, *continued*

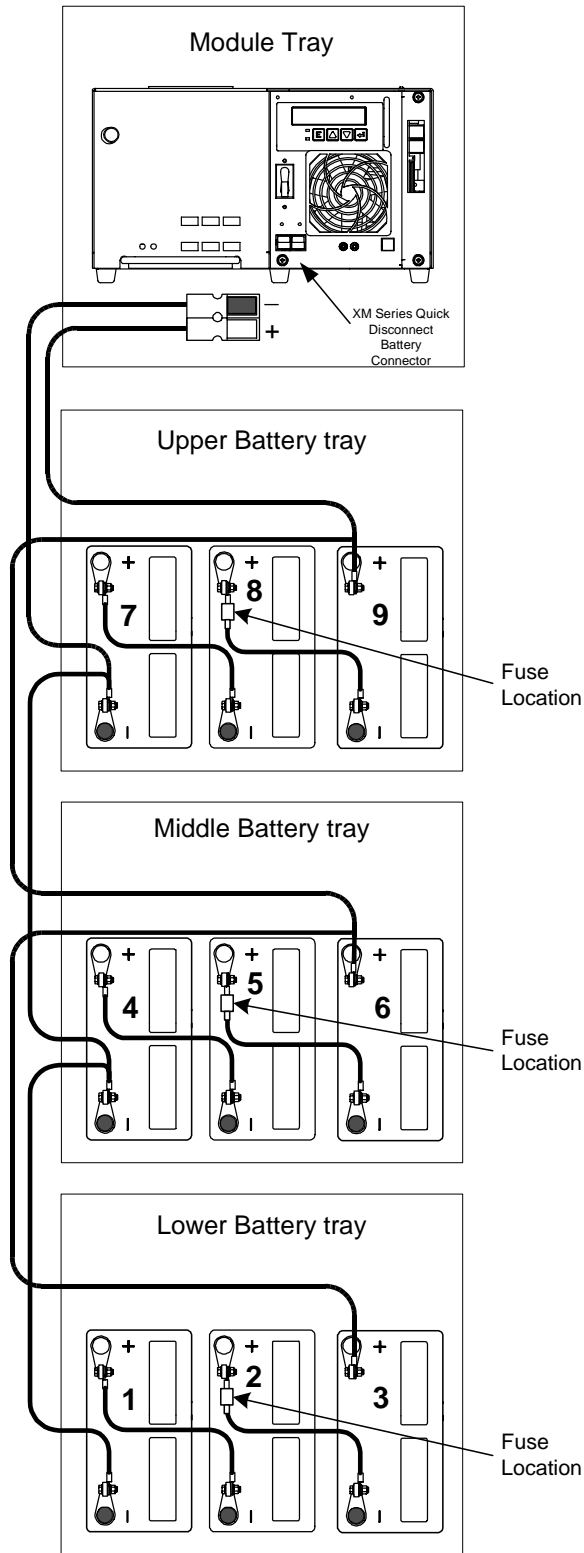

Figure 3-21; Wiring Diagram for three 36V Battery Strings — PN4 Enclosure

## 3.5.6 PN4 Battery Arrangement, Power Supply Connection, *continued*

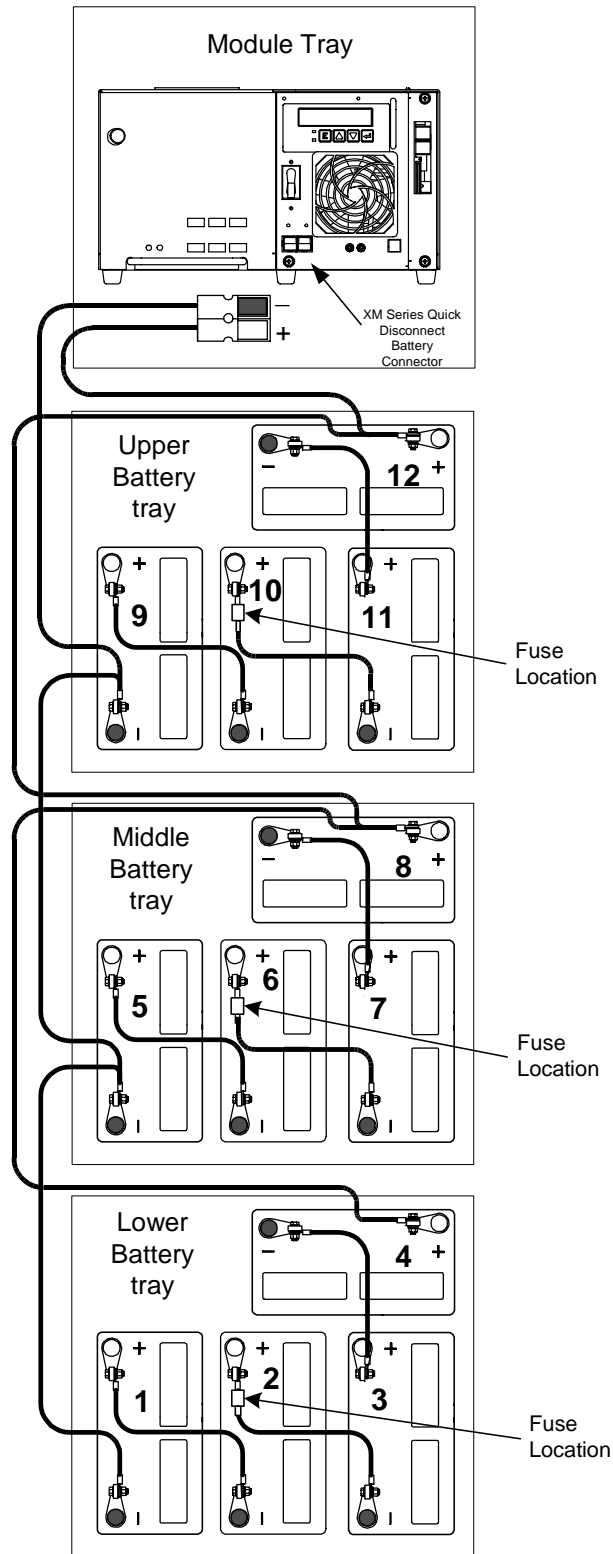

Figure 3-22; Wiring Diagram for three 48V Battery Strings — PN4 Enclosure

# 3. Installation

## 3.5.7 Battery Temperature Sensor

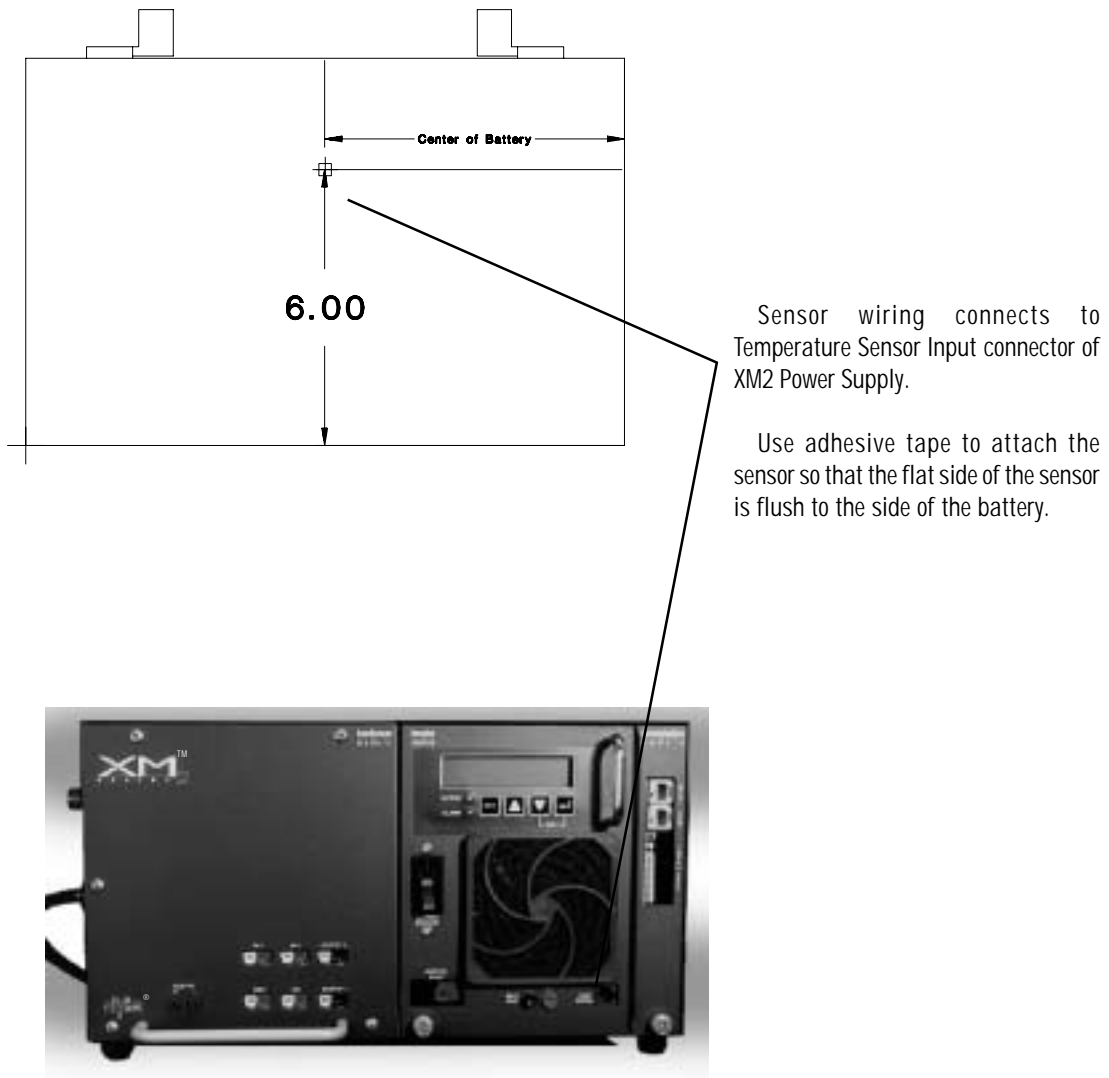

Figure 3-23; Battery Temperature Sensor Mounting Location

To prevent incorrect temperature readings, attach the Battery Temperature Sensor associated with each XM2 Power Supply on different batteries.

# 4. PN Series Options

## 4.1 Star Lock Security Bolt

See section five, "Alpha Part Numbers" for PN Series options shown in this section.

The Star Lock Security Bolt kit comes factory installed when ordered with a new enclosure. The kit can also be added to existing enclosures using the procedure below.



**NOTE:** The Security Key is a special tool that must be ordered separately. Alpha recommends ordering security keys for each maintenance crew.

- 1). Drill dimple located approximately half way down enclosure doors.



Figure 4-1; Security Bolt Location

- 2). Place black clip over flange and align with factory-drilled hole in flange.



Figure 4-2; Black Clip in Place

- 3). Place bolt into hole, apply retaining washer, and tighten with Security Key.



Figure 4-3; Retaining Washer



Figure 4-4; Security Key (Part Number 647-089-10)

## 4. PN Series Options

### 4.2 Battery Interface Unit (BIU)

The BIU is used in Pownode systems with multiple power supplies and/or multiple battery strings, and an AlphaGen DC generator. The BIU provides a parallel DC bus with convenient connectors for each power supply and battery string.

(For installation and operation instructions, refer to the BIU Installation Manual, part number 018-311-C1.)

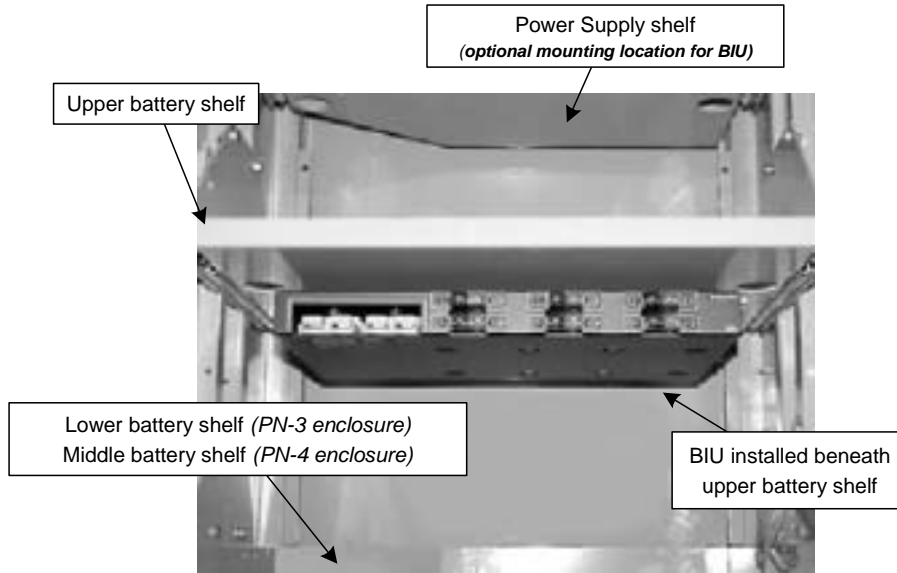

Figure 4-5; Battery Interface Unit in Place

### 4.3 Service Disconnects

There are four Service Disconnects available (installed at the factory):



Figure 4-6; BBX 70A (BBX-F12)  
Square-D, 2-position  
For single power supply applications



Figure 4-7; BBX 100A (BBX-F18)  
Square-D, 8-position  
For multiple power supply applications.

# 4. PN Series Options

## 4.3 Service Disconnects, *continued*

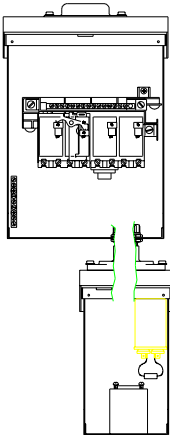

Figure 4-8; MTS (Showing 100A and 60A boxes)

For applications requiring a protected AC generator.



Figure 4-9; FBX-60A

Fused safety switch. For applications with high AIC rating requirements.

## 4.4 Input Power Panel (IPP)

There are four basic configurations of the IPP. Each is available in 120V and 240V. Units in figures 4-10, 4-11, and 4-12 are factory pre-wired, include Square-D high-magnetic breakers for each power supply, and provide a GFCI convenience outlet.



Figure 4-10; IPP for Three Power Supplies



Figure 4-11; IPP for Two Power Supplies



Figure 4-12; IPP for One Power Supply



Figure 4-13; Breaker Duplex Option (BDO) for One Power Supply (NOT factory pre-wired.)

## 4. PN Series Options

### 4.5 Cooling Fan Kit

When using more than one power supply in the PN Series Enclosures, a cooling fan is required. The Cooling Fan kit includes an intake filter, located inside the front door of the enclosure by the ventilation louvers. The filter must be cleaned periodically as part of the power supply preventative maintenance program.

Replacement fuses and filters are available. Refer to section five for part numbers.



Figure 4-14; Cooling Fan Panel

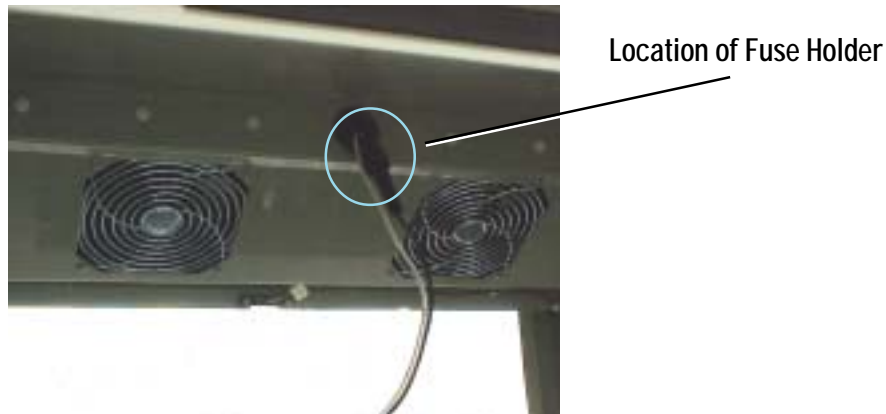

Figure 4-15; Panel is Installed in Top Rear of Enclosure



Figure 4-16; Cooling Fan Plugged into Power Supply and SPI

## 4.6 Lightning Arrester (LA-P+)

The Lightning Arrester is available in 120VAC and 240VAC, and is installed by plugging into an IPP or BDO.



Figure 4-17; LA-P+ Installed in BDO

The unit is operating properly when the green LED is lit.



Figure 4-18; Location of LED on LA-P+.

# 5. Alpha Part Numbers

## 5.1 PN Series Options

<b>Item:</b>	<b>Part Number:</b>
Star Lock Security Bolt	744-897-20
Security Key	647-089-10
Battery Interface Unit (BIU)	018-311-24
Service Disconnects	
BBX-70A	744-656-20
BBX-100A-8POS	744-657-20
MTS 240-40	SPB99-512-12
FBX-60A	744-534-20
Input Power Panels (IPP) (Pre-Wired)	
IPP-CE, 1x240 1xGFCI	744-735-20
IPP-CE, 2x240 1xGFCI	744-701-20
IPP-CE, 3x240 1xGFCI	744-868-20
IPP-CE3x/9x 120V for BATT HTR	744-702-20
IPP-CE, 1x120 1xGFCI	744-735-21
IPP-CE, 2x120 1xGFCI	744-701-22
IPP-CE, 3x120 1xGFCI	744-868-21
IPP-CE, 3x120 1xGFCI 120Vin	744-868-22
BDO (NOT installed)	
BDO-515 120V 15A <b>Not SUSE Rated</b>	744-148-20
BDO-520 120V 20A <b>Not SUSE Rated</b>	744-148-21
BDO-615 240V 15A <b>Not SUSE Rated</b>	744-147-21
Cooling Fan Kit	744-839-20
Replacement Fuse	460-025-10
Replacement Filter	
Lightning Arrester	
LA-P+ 120V (L-N, L-G, N-G)	020-098-24
LA-PC+ 120V (L-N, L-G, N-G)	020-098-26
LA-PE+ 240V (L1-L2, L1-G, L2-G)	020-098-25
Extra SPI (15 Amp)	744-279-22
Extra SPI (25 Amp)	744-789-21



**NOTE:** Alpha part numbers are correct at the time of printing. As part numbers are subject to change, please contact your Alpha Representative prior to ordering to ensure that numbers are correct.

# 5. Alpha Part Numbers

## 5.2 Pre-Cast Concrete Pads

Alpha offers a line or precast, polymer concrete and reinforced concrete pads for the PN Series Enclosures. Polymer concrete is significantly lighter and more stable when compared to reinforced concrete. Both materials represent a significant savings in labor costs and quality improvement over "pour-in-place" pads. Other precast pad configurations are available. Contact your nearest Alpha representative for additional information.

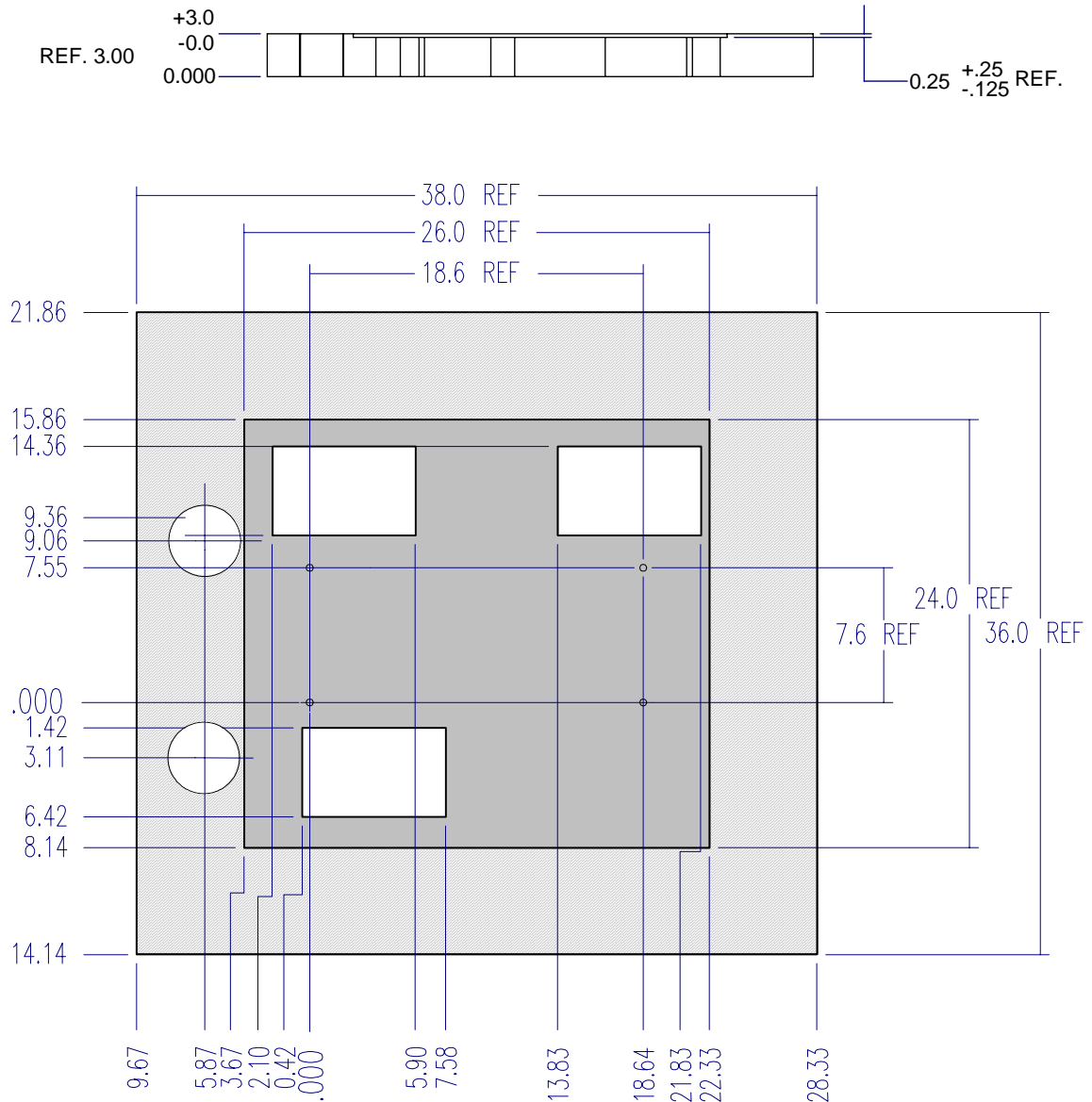

Figure 5-1; Single-Wide Pad, for CE8/9 or PN 3/4

Part Number:

PCD-3: 641-070-10 (Reinforced concrete)

PCC-3: 641-067-10 (Polymer concrete)

# 5. Alpha Part Numbers

## 5.2 Pre-Cast Concrete Pads, *continued*

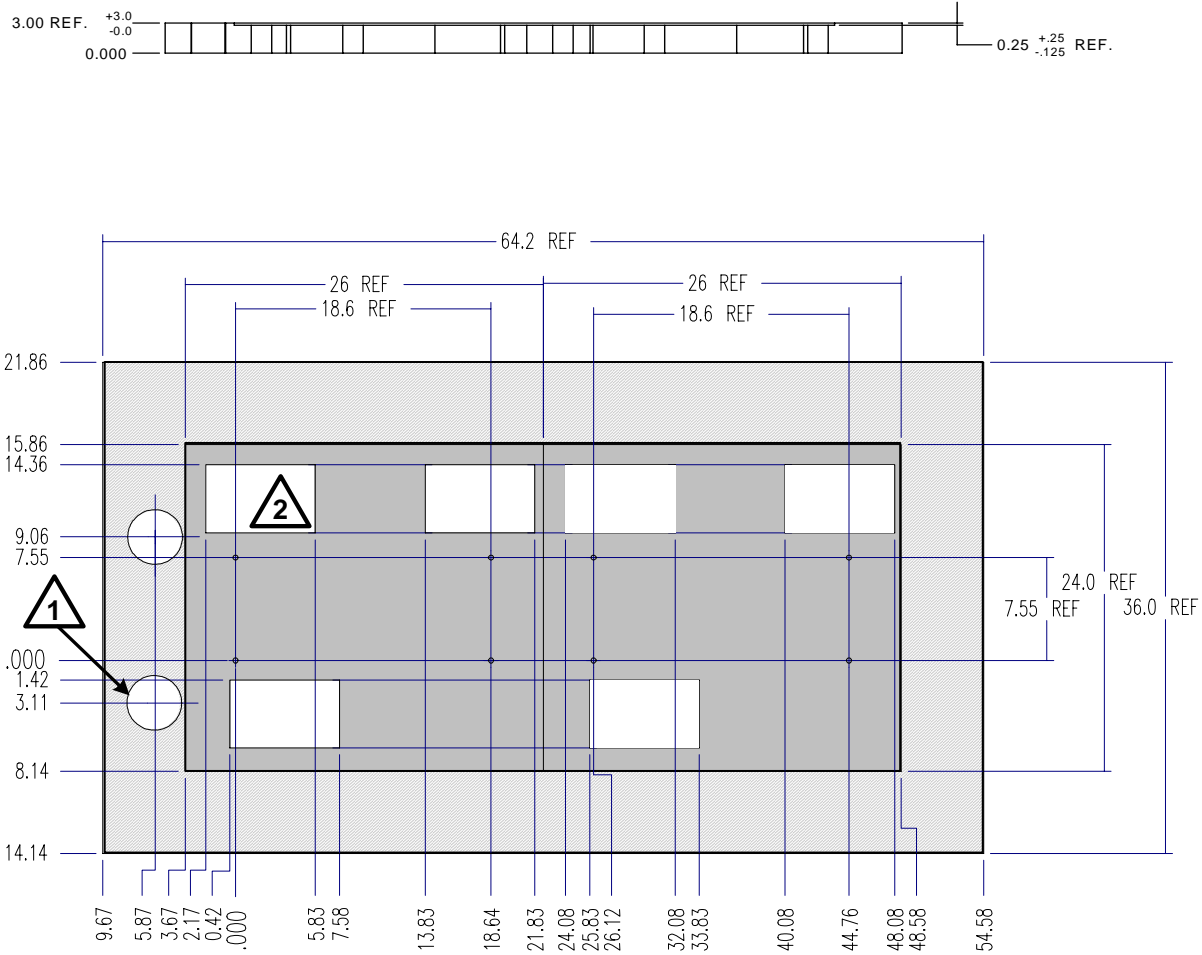

Figure 5-2; Double-Wide Pad, for CE8/9 or PN 3/4

Part Number:

PCD 3-3: 641-072-10 (Reinforced concrete)

PCC 3-3: 641-069-10 (Polymer concrete)



4" diameter opening (2 plcs.)



5" x 8" opening (6 plcs.)

# 5. Alpha Part Numbers

## 5.2 Pre-Cast Concrete Pads, *continued*

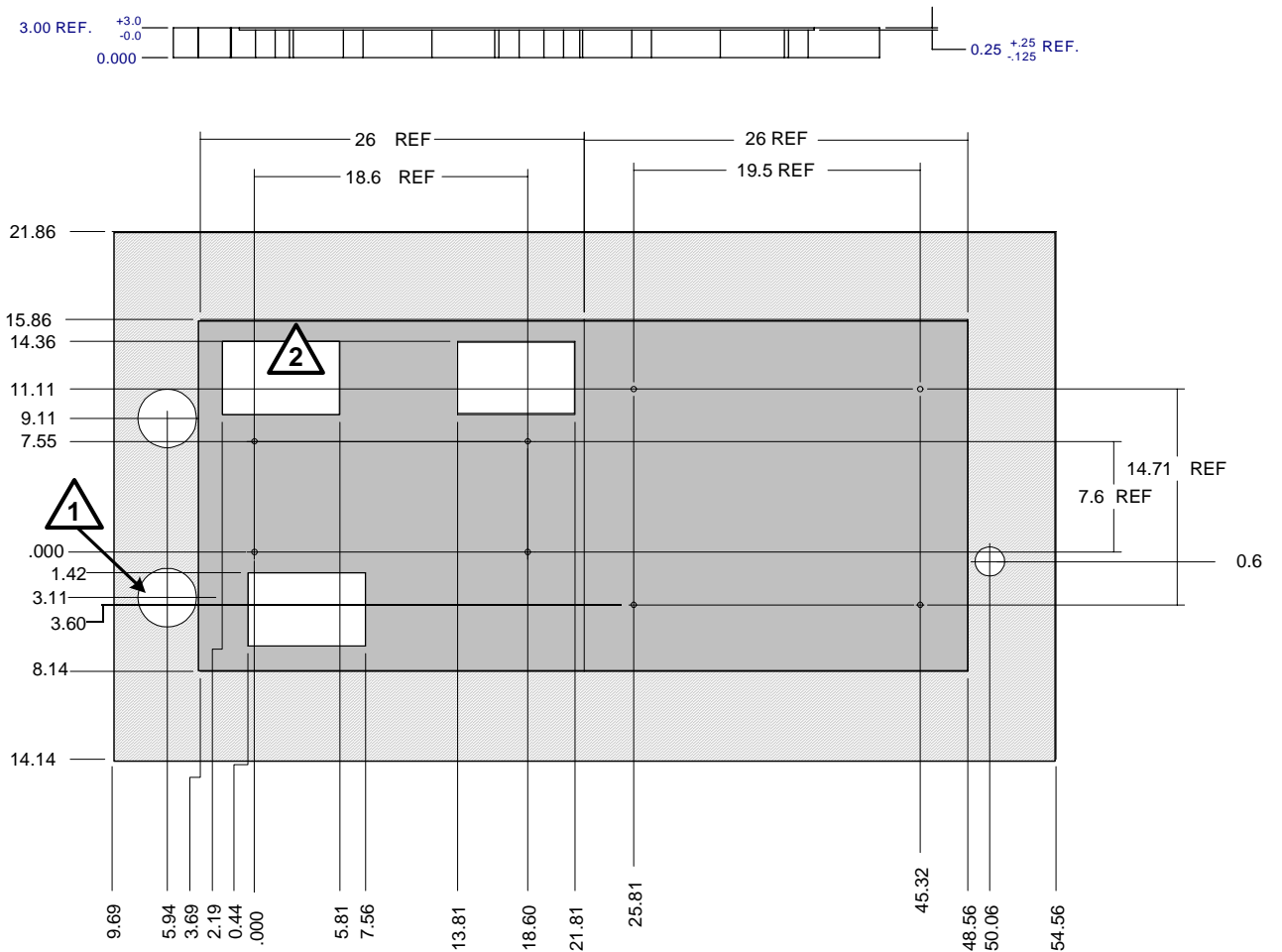

Figure 5-3; Double-Wide Pad, for CE 3x2/9x2 and CE8/9 or PN 3/4

Part Number:

PCD 3-3x: 641-071-10-003

PCD 3-3x: 641-068-10-003

**1** 4" diameter opening (2 plcs.)

**2** 5" x 8" opening (3 plcs.)





# [Power]

[www.alpha.com](http://www.alpha.com) Protecting The Power in Communications.

**UNITED STATES**  
**ASIA PACIFIC**  
**LATIN AMERICA**  
Alpha Technologies  
3767 Alpha Way  
Bellingham, WA 98226  
Tel: (360) 647-2360  
Fax: (360) 671-4936  
Web: [www.alpha.com](http://www.alpha.com)

**CANADA**  
Alpha Technologies Ltd.  
4084 McConnell Court  
Burnaby, BC, V5A 3N7  
Tel: (604) 430-1476  
Fax: (604) 430-8908

**UNITED KINGDOM**  
Alpha Technologies Europe, Ltd.  
Cartel Business Estate  
Edinburgh Way  
Harlow, Essex CM20 2TT  
Tel: +44-1279-422110  
Fax: +44-1279-423355

**GERMANY**  
Alpha Technologies  
Hansastrasse 8  
Schwabach D-91126  
Tel: +49-9122-79889-0  
Fax: +49-9122-79889-21

**MIDDLE EAST**  
Alphatec, Ltd.  
339 St. Andrews St., Suite 101  
Andrea Chambers  
Limassol, Cyprus  
Tel: +357-25-375675  
Fax: +357-25-359595

**AUSTRALIA**  
Alpha Technologies  
8 Anella Ave., Unit 6  
Castle Hill, NSW 2154  
Tel: +61-2-9894-7866  
Fax: +61-2-9894-0234