



# White Paper

Powering Trends  
and Issues for IP  
Telephony Over CATV

## Powering Trends and Issues for IP Telephony Over CATV

Dr. Thomas H. Sloane  
(tsloane@alpha.com)

Alpha Technologies, Inc.

Power is a critical component of the reliability and robustness of the cable TV plant and thus directly affects the quality of telephony services provided over cable TV architectures. Although present-day telephony over cable TV uses circuit-switched techniques, in the next year or so Internet Protocol (IP) telephony will become available. Through the use of IP telephony over cable, the cable modem providing IP data for the internet can also provide telephony. Today, cable systems provide video through a setup box, high-speed internet access with a cable modem, and telephony with a network interface unit (NIU) mounted at the customer premises. Compared to present video-only powering architectures, both forms of telephony change the powering requirements, but fortunately with planning and foresight, powering solutions for today's circuit-switched NIUs are also appropriate for upcoming IP telephony.

### 1. Standby Powering

The utility power grid and the architecture of the HFC distribution system are typically different. Between the optical node and the final customer drop, the HFC distribution system typically weaves through several ac utility distribution grids, any one of which may differ from the utility grid providing power to the customer. With non-standby power supplies powering this HFC system, a utility outage anywhere between the optical node and the customer tap causes an interruption in the video. The duration of this interruption is approximately equal to the duration of the utility outage: a one-cycle drop in the utility power produces a momentary outage in the video.

A different situation exists with more advanced services, including digital video, data, and telephony. A short, two or three-cycle interruption in the utility power anywhere between the optical node and the customer tap causes a longer, more bothersome disruption in the customer services. A telephone call in progress may be dropped, forcing the customer to initiate a new call, or with data this momentary utility outage can cause a complete drop in the data connection. Standby power supplies offer a solution to these problems.

Standby power supplies use batteries to provide CATV powering waveforms which are completely unaffected by utility outages, yet in normal operation these power supplies operate with the same high efficiency as a non-standby power supply. Figure 1 contains an example of the output waveform during the transitions to and from battery and utility powering. A three-battery string typically supports standby operation for two to three hours, dependent on the load and other factors. For different reasons, with telephony, longer standby times are often needed. In the U.S., an eight-hour minimum standby time is mandated for a system carrying telephony traffic.

There are two approaches to extending the run times of these standby power systems. Most obviously, additional

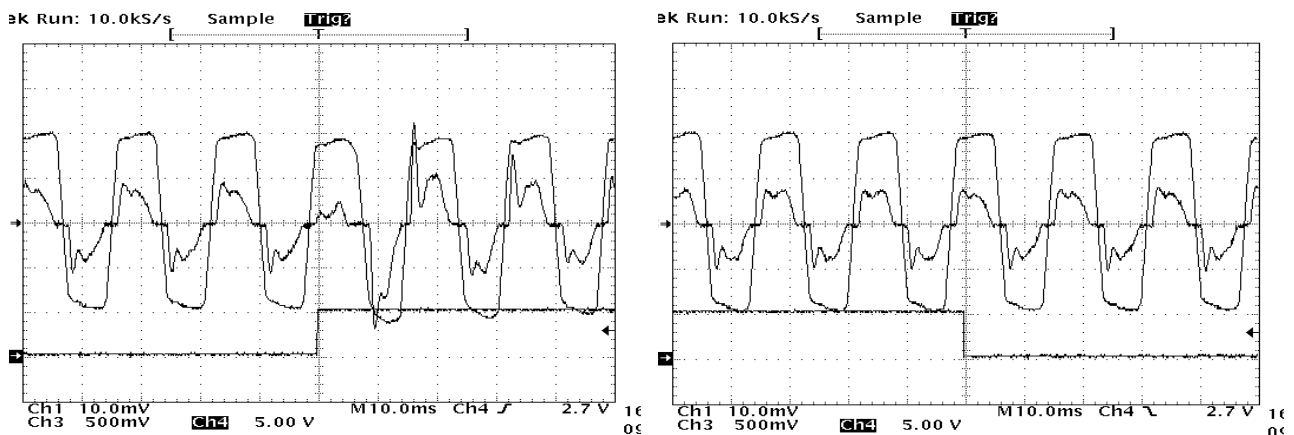

Figure 1. Examples of  $XM_2$  transitions between utility powering and standby powering using CATV load.

batteries can be used, either as a parallel string, or with larger ampere-hour batteries in a single string. In either case, the recharge time for these larger battery strings is often overlooked. The battery charger in the standby power supply must have sufficient charger amperage available to recharge the battery string in a reasonable time as well as a three or four-state charging algorithm to ensure long battery lifetimes. In 24 hours, a 10-A, three-state charger completely recharges two parallel battery strings, each string made up of three 100-ampere-hour (AH) batteries. The three-state charger provides rapid recharging during the initial state, a second state for equalizing the state of charge among the batteries, and finally a fourth constant-voltage state which minimizes the heating of the battery to attain maximum battery life.

Battery lifetimes are directly affected by the ambient battery temperature. For every 10°C increase in continuous ambient temperature, battery lifetimes are reduced by one half. During battery charging, very small quantities of hydrogen gas are produced by the batteries. Hydrogen can not be permitted to accumulate above a 4 percent volumetric concentration. Temperature-compensated charging has long been used by Alpha, and now others, to extend battery life and minimize battery hydrogen generation which thus reduces enclosure hydrogen accumulation. A properly designed enclosure offers complete protection from hydrogen accumulation, even in the event of shorted cells in the battery string and other charger or battery malfunctions. The true test of enclosure design are billions of hours of proven, safe field operation.

A second approach to extending battery run times is the use of a standby engine-generator (E-G). When providing standby power to two power supplies, a standby E-G offers a lower costs of ownership when compared to eight hours of standby using batteries. Furthermore, a standby E-G connected to the residential natural gas supply offers unattended operation of up to 200 hours (compared with the eight hours of a battery string).

Equally as important as standby powering times are the reliable startup and short-circuit recovery of the network. The network actives (amplifiers, line extenders, bridgers, etc.) possess a low-voltage disconnect which is just greater than one-half the normal supply voltage. During network startup, or in recovery from a short circuit, as the network voltage rises from 0V, the constant-power characteristics of the actives create a significant current draw at the low-voltage disconnect voltage. For instance in a 60-V system, with a normal steady-state load of 10A, the load at the 30-V low-voltage disconnect is 20A. The power supply for this HFC network must have sufficient excess current capacity to allow the network voltage to rise above the low-voltage disconnect voltage and reach the normal steady-state voltage. Conversely a power supply with excessive short-circuit current capacity can put too much current into the network, causing damage to network actives. In situations where power supplies with larger, rated current capacities (22A) can produce fault currents in the network in excess of the tolerable network current, the XM<sub>2</sub> offers an optional electronic protection device which functions as an electronic circuit breaker protecting the network.

## **2. Changes Produced by Telephony**

Two principle changes result from carrying telephony traffic over the CATV network: (1) substantial increases in the duration of standby operation, both for network devices such as the optical node, amplifiers, line extenders, and other active devices, and also for the NIUs; (2) a method of powering is needed for the NIUs located at the residence of each telephony customer. Presently with circuit-switched telephony, these NIUs consume about 6W and the first generation of IP-based telephony NIUs will consume about 10W with the immediate goal to reduce this to 6W in following generations. Increases in duration of standby operation can be supported with larger battery ampere-hour energy storage or by using curbside E-Gs which convert energy in the natural gas or propane to electrical power.

These telephony-based NIUs are not in the conventional HFC plant, but are located at customer premises. Three options are available to power these NIUs: (1) utility powering; (2) home-based power supply; and (3) network powering through a power-passing tap. The reliability of utility power, considering outages, brownouts, surges, and other anomalies, is too low to permit a telephony NIU to rely only on utility power. A battery backed up, home-based power supply which uses utility power in normal operation and a battery backup in periods of utility failure is a second option, however, several problems exist. Such a home-based NIU power supply occupies one utility outlet at each residence, which in residences with a shortage of utility outlets can be very inconvenient. Use of a home-based power supply differentiates the telephony services provided by CATV from traditional, central-office-powered telephony and consumers may not perceive this difference positively. Most often, the battery with this home-based power supply provides eight hours of telephone operation. If a utility outage extends beyond this eight-hour battery standby time, the telephony supported by the NIU fails. Yet another shortcoming of this home-based supply is that the batteries eventually age such that they no longer offer the desired standby time, and thus must be replaced. The cost and nuisance of replacing the batteries at a customer residence can be significant.

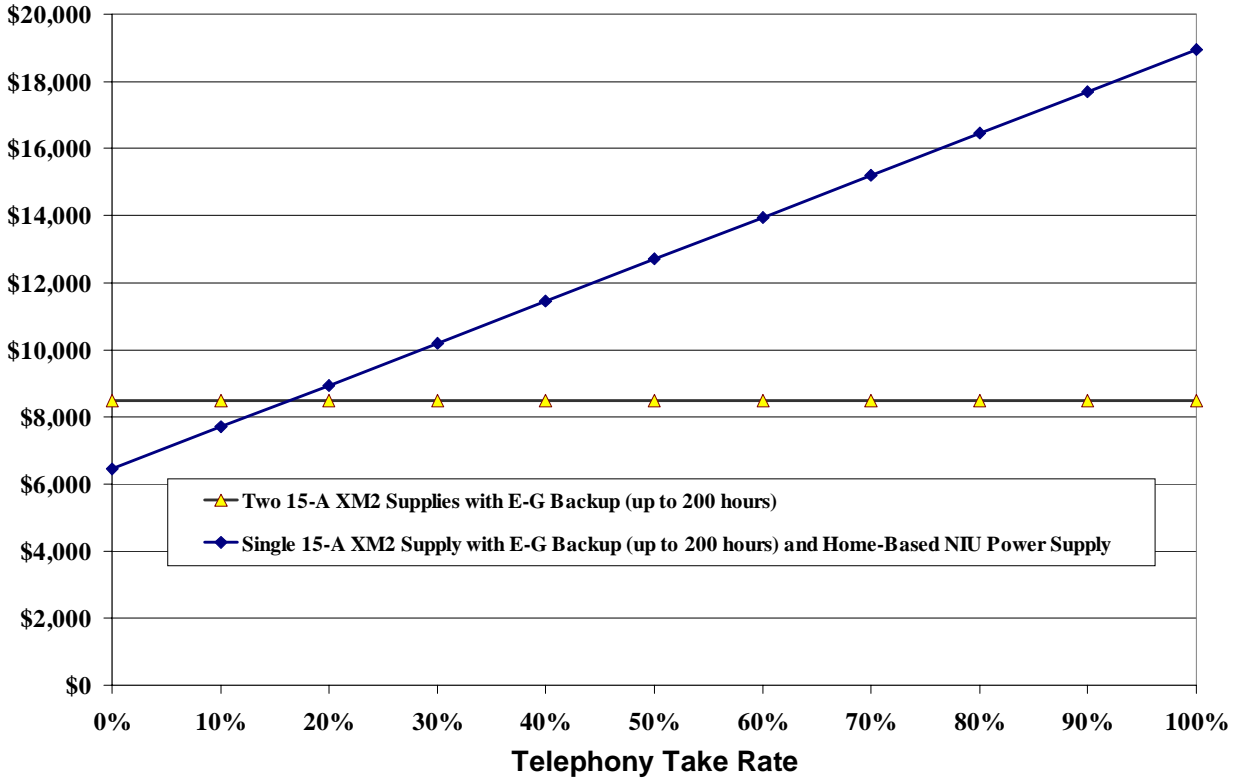

Figure 2. NIU powering alternatives: network powering or home-based powering, with backup provided by an E-G.

The third telephony NIU powering option is network powering. Power passing taps are needed, but these are commonly available and the cost of such taps is decreasing. Network powering of the NIUs provides a centralized powering point for a portable or integral E-G to provide long-term power backup in the case of extended utility outages. Cost comparisons between network powering of NIUs and a home-based power supply for these NIUs are useful. In either case, the network electronics (actives) must be powered with a source offering sufficiently-long network operation during utility outages. For home-based powering of an NIU, as each telephony customer is added, a the home-based power supply must be provided and installed at the customer premises. One estimated cost of this is \$US50. With network powering of these NIUs, the power rating of the network power supply may need to be increased, or quite often the present network power supply is loaded to less than the maximum of 80 percent of its rating. The maximum load of 80 percent of rated, as recommended by the SCTE powering reliability committee, is to ensure reliable startup of the network. Figure 2 illustrates the costs of these two NIU powering alternatives. As the percentage of telephony subscribers increases, the costs of network powering the telephony NIUs is unchanged, and above about 20 percent telephony penetration, the network powering costs are less than home-based powering. At significant telephony penetrations, home-based powering of the NIUs can add considerable costs to powering, more than double the costs of network powering at 100-percent telephony penetration.

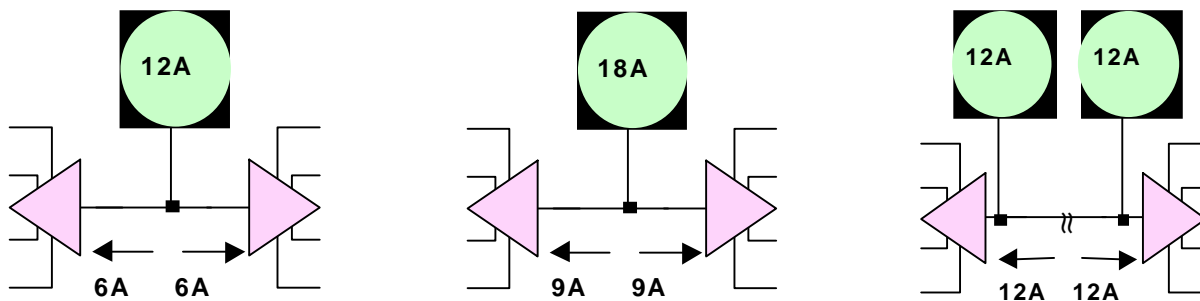

Figure 3. Increasing power into network for powering telephony NIUs. From a single 15-A supply providing 12-A to the network, to a 22-A supply providing 18-A of network power, to two 15-A supplies with a total of 24-A of network current.

If the network power supply is loaded to less than 80 percent of its rating, the additional cost of to power an NIU is the cost of the power-passing tap. Two alternatives are available to support additional loads as more NIUs are added. A power supply with a 15-A rated output current is by far the most common size of power supply. As additional telephony loads are added, this 15-A supply can be replaced by a 22-A power supply which is the same physical size and thus fits into the same enclosures as the original 15-A supply. This 50-percent additional power from the 22-A supply can support as many as 60, 6-W telephony NIUs. These various network powering options are shown in Fig. 3. At a site with a single 15-A power supply, where the power inserter is passing power both east and west, two 15-A power supplies can be used. With two 15-A power supplies, each has a power inserter which passes power into one side of the network.

### 3. Transfer Characteristics

Earlier, in Figure 1, the transfer characteristics of an  $XM_2$  are seen. The significance of the seamless transition between standby operation and normal operation is apparent when the holdup times of the active devices are considered. Most active devices, such as amplifiers, line extenders, and other network electronics, provide some holdup time, typically one or two cycles. Holdup time is the time for which an interruption in the input waveform does not affect operation of the device. For an active device with a 40-ms holdup time, it might seem that utility-to-inverter and inverter-to-utility transfers with momentary outages less than 40ms could be tolerated. However, holdup time is not constant and varies as a function of operating voltage. Holdup time is created from the energy storage capacity of a capacitor at the input section of these active network devices. Energy stored in this capacitor is equal to  $\frac{1}{2}CV^2$ . Voltage throughout the HFC network is not constant, and because of the resistance of the coax cable, the system voltage is less and less as the distance between the active device and power supply grows larger. At the greatest possible distance, the voltage is reduced to one-half the supply voltage. For stability, active network electronics do not operate at a voltage less than one-half the normal supply voltage. The voltage below which the active network electronics disconnect and form an open circuit, is referred to as the low-voltage disconnect level.

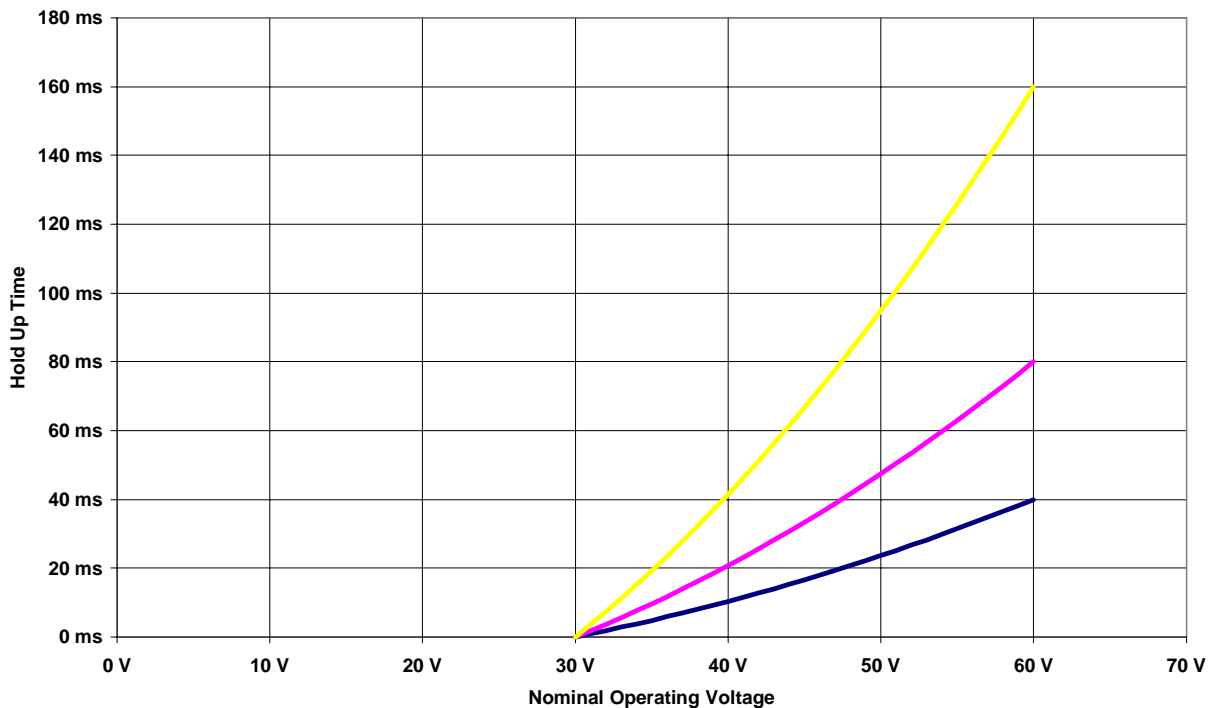

Figure 4. Three examples of holdup times as a function of network operating voltages. At a 60-V operating voltage, three different holdup times are shown: 40ms, 80ms, and 160ms. Note that all three decrease dramatically at lower operating voltages.

Active electronics must function at voltages ranging from the 60-V when located near the power supply, to as low as 30-V at some distance from the power supply. Because the energy storage capacity of these active electronics is based on an input capacitor, the holdup time varies as a function of the operating voltage. At lower operating voltages, the holdup time is greatly diminished. This is seen in Fig. 4. Active devices which are farther from the power supply, and thus operate at voltages less than the supply voltage, have considerable shorter holdup time than the same active device operated at normal network voltage. In such a situation, the seamless transition of a power supply between utility operation and standby operation is essential to avoiding any dropout of the active devices. In networks with IP-based telephony or data traffic, even a very short powering outage can lead to unacceptably lengthy network recovery time as dropped packets are recovered and retransmitted and telephony connections reestablished.

#### 4. Battery Run Times

As electrochemical energy storage devices, batteries offer very effective energy storage under most operating conditions, but ambient temperatures directly affect battery capacity. Specifically at lower ambient temperatures, battery standby times decrease. For example compared with operation at 25°C, a battery has about 22 percent reduction in standby time at 0°C. Battery standby times vary with the cable plant load too. In Fig. 5 below, standby times for two different AlphaCell batteries, the AlphaCell 180GXL and AlphaCell 165GXL, are plotted as a function of power supply ac output current to the cable TV plant for a single three-battery string and two parallel three-battery strings. The additional standby time offered by a parallel string can be very important for telephony services. Because discharge rates affect battery ampere-hour capacity, adding a second string produces standby times which are slightly more than twice the standby time of a single string. With two parallel strings, each string has a lower discharge rate which provides greater ampere-hour capacity for each string. At this lower discharge rate, the ampere-hour capacity is slightly increased thus providing a standby time slightly greater than twice that of a one-battery string.

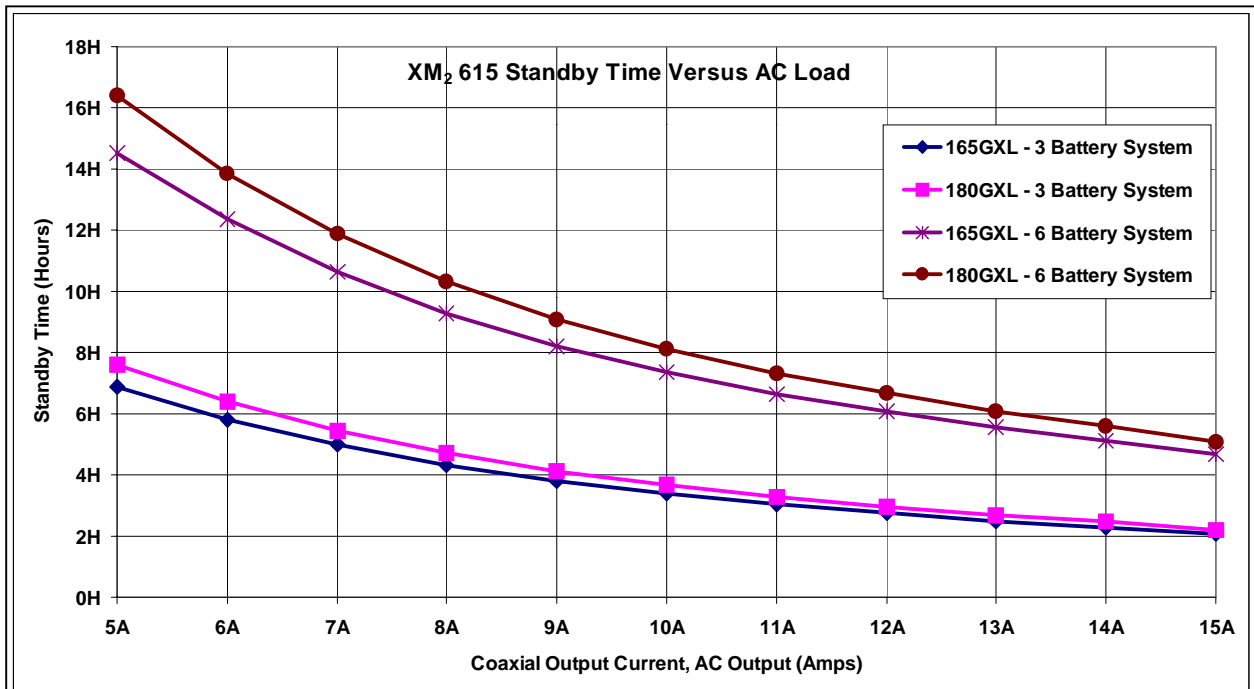

Figure 5. AlphaCell 180GXL and 165GXL battery run times for different XM<sub>2</sub> output currents loads into the CATV plant.

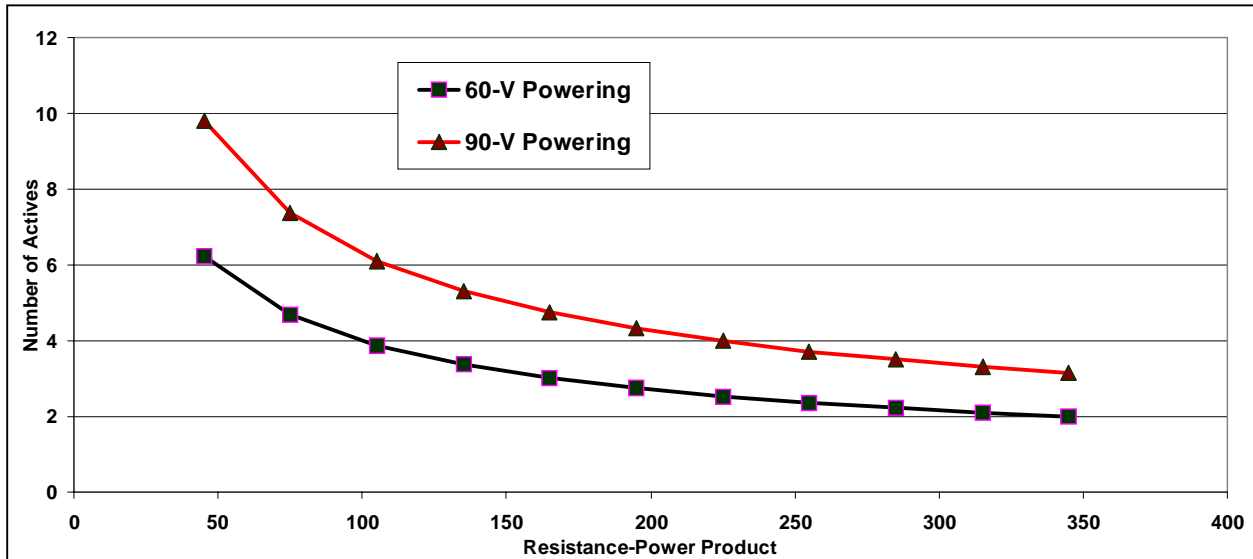

Figure 6. Increase in the number of actives in a string produced by changing from 60-V powering to 90-V powering. The resistance-power product refers to the coaxial resistance between actives and power is the constant-power load of the active.

## 5. Powering Waveforms at 60V and 90V

Within most of North America, 90-V powering is completely acceptable to local safety and regulatory agencies. However, for the portion of the CATV plant which is within a multiple dwelling unit (MDU), the restrictions of the safety codes limit voltages to 60V. Use of 90-V powering allows the longer standby times and option redundancy to be more cost effective since a single power supply location can provide power to a larger quantity of actives and these actives can also be located at greater distances from the power supply. The resistive drop along the resistance of the coax causes a voltage drop, which given that actives must operate at a voltage above the low-voltage disconnect, limits the distance between amplifiers and the power supply. The power level of the amplifiers' constant-power load also affects the maximum distance between amplifier and power supply. For a single string of amplifiers, using a coax cable with fixed resistance per unit length, a change in powering from 60V to 90V allows a 225 percent increase in the amplifier power, or a 225 percent increase in distance between the amplifiers and power supply. Thus, as telephony services are added, and as plant bandwidth is upgraded, the additional power demand of the upgraded actives can be accommodated with the existing power supply locations if the power supply is capable of changing the powering voltage from 60V to 90V, and if regulatory issues permit 90-V powering.

An alternative to examining the increased reach or active power capacity, is to examine the increased quantity of actives which can be powered from a single supply as the powering voltage changes from 60V to 90V. If each active consumes  $P$  watts, and the coaxial resistance between actives is  $R$ , the quantity  $P \times R$  controls the maximum number of actives. If the actives are located close to the power supply, and thus  $R$  is small, then these actives can be larger power actives. Figure 6 illustrates the increase in the number of actives, for a range of values of  $P \times R$ , which can be powered from a single power supply as the powering voltage is changed. Examination of Fig. 6 shows that the quantity of actives can be increased by just more than 50 percent when changing from 60V powering to 90V powering.

Another feature which supports an increased distance between the power supply and actives is the voltage waveshape produced by the power supply. As loads, the actives electronics in the HFC plant are nonlinear and function essentially as a rectified capacitive load. With a sinusoidal voltage waveform, current into this type of load occurs for a very brief portion of the period, at the peak of the voltage waveform. The patented quasi squarewave output waveform produced by the Alpha Technologies'  $XM_2$  and  $AM_2$  power supplies produces a current waveform which extends over a much greater portion of each half cycle than with a sinusoidal waveform. Also by design, the rise and fall times of the quasi squarewave waveform are selected so that there is no interference with the CATV and broadband signals.

## **6. Conclusions**

Performance criteria of a CATV power supply have been examined, specifically with respect to emerging architectures which support Internet Protocol (IP) telephony. Powering choices for today must support a migration path for future, enhanced services which required longer standby times and place additional powering loads on the HFC network.