

USM2.5 Status Monitoring Module
with Acterna Embedded Transponder
Technical Manual

Effective: September, 2003

Power

Alpha Technologies

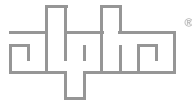



USM2.5 Status Monitoring Module *with Acterna Embedded Transponder*

Technical Manual

018-041-C0-003 Rev. C — © 2003 by Alpha Technologies, Inc.
Effective: September 2003



Statement of Intended Usage

Alpha denies responsibility for any damage or injury involving its enclosures, power supplies, generators, batteries, or other hardware when used for an unintended purpose, installed or operated in an unapproved manner, or improperly maintained.



Information on CE Compliance

Alpha Technologies Communications Module, model USM 2.5, has been qualified as an EMC Class B product, when configured in an Alpha Uninterruptible Power Supply (UPS) product. When an (optional) Acterna Embedded Transponder Assembly is configured in an Alpha UPS with model USM 2.5 Communications Module, the resultant UPS product configuration complies only to Class A requirements, in accordance with the EMC Directive and applicable Technical Standards.

Contacting Alpha Technologies:

For general **product information and customer service**

1-800-863-3930

(7:00 AM to 5:00 PM Pacific Time)

For complete **technical support**

1-800-863-3364

(7:00 AM to 5:00 PM Pacific Time, or 24/7 emergency support)

Table of Contents

Safety	5
1. Installation	9
1.1 Installation in an XM Series 2 Power Supply	9
1.2 Transponder Inputs and Outputs	11
1.3 Battery Monitor Connections	12
1.4 Generator Connection	19
1.5 Generator Ignition Battery Connection	20
1.6 COMM and RF Connections	21
2. Specifications	22
2.1 Channel Parameters	22
3. Troubleshooting	23
3.1 Important Troubleshooting Notes	23
3.2 Troubleshooting Specifics and Testing	25
4. Part Numbers	26
4.1 Cable Kit Options	26

List of Tables and Figures

Figure 1-1	Transponder Installation	10
Figure 1-2	Input / Output Connections	11
Figure 1-3	Battery Monitor Connections for three 48Vdc battery packs	12
Figure 1-4	Battery Monitor Connections for two 48Vdc battery packs	13
Figure 1-5	Battery Monitor Connections for one 48Vdc battery pack	14
Figure 1-6	Battery Monitor Connections for one 36Vdc battery pack	15
Figure 1-7	Battery Monitor Connections for two 36Vdc battery packs	16
Figure 1-8	Battery Monitor Connections for three 36Vdc battery packs	17
Figure 1-9	Battery Monitor Connections for four 36Vdc battery packs	18
Figure 1-10	Generator Monitor Connections	19
Figure 1-11	Generator Ignition Battery Connection	20
Figure 1-12	COMM / RF Connections	21
Figure 3-1	Battery String Example	24
Table 2-1	Channel Parameters	22
Table 4-1	Cable kit part numbers	26

Safety Notes



This symbol identifies conditions and actions that pose a hazard to the user.



This symbol cautions the user of conditions and actions that may damage the power supply or associated equipment.



This symbol identifies a condition that may be corrosive to equipment and parts, or damaging to skin.



This symbol identifies a condition in which it is required to recycle discarded materials.



This symbol identifies a situation in which static-sensitive components are present.

Warnings



WARNING: This power supply and its associated hardware (enclosure, batteries, cabling) may contain equipment, batteries or parts which have accessible hazardous voltage or currents.

To avoid injury:

- This power supply and its associated hardware must be serviced by authorized personnel only.
- The enclosure which contains the power supply and associated equipment must remain locked at all times, except when authorized service personnel are present.
- Remove watch and/or jewelry prior to servicing equipment, parts, connectors, wiring, or batteries.
- Read and follow all installation, equipment grounding, usage, and service instructions included in this manual.
- Use proper lifting techniques whenever handling equipment, parts, or batteries.
- Batteries contain dangerous voltages, currents and corrosive material. Battery installation, maintenance, service and replacement must be performed by authorized personnel only.
- Never use uninsulated tools or other conductive materials when installing, maintaining, servicing or replacing batteries.
- Use special caution when connecting or adjusting battery cabling. An improperly connected battery cable or an unconnected battery cable can result in arcing, a fire, or possible explosion.
- A battery that shows signs of cracking, leaking or swelling must be replaced immediately by authorized personnel using a battery of identical type and rating.

Warnings, continued

- Avoid any contact with gelled or liquid emissions from a valve-regulated lead-acid (VRLA) battery. Emissions contain dilute sulfuric acid which is harmful to the skin and eyes. Emissions are electrolytic, which are electrically conductive and are corrosive. Follow the Chemical Hazards notes if contact occurs.
- Do not smoke or introduce sparks in the vicinity of a battery.
- Under certain overcharging conditions, lead-acid batteries can vent a mixture of hydrogen gas which is explosive. Proper venting of the enclosure is required.
- Follow the battery manufacturer's approved transportation and storage instructions.

Cautions



NOTE: Equipment or parts may be damaged or cause damage if used or installed improperly.

To avoid damage:

- Prior to installation, verify that the AC input voltage to the enclosure and its equipment match with respect to voltage and frequency.
- Prior to installation, verify that the output voltage from the enclosure or its equipment match the voltage requirements of the connected equipment (load).
- Prior to installation, verify that the enclosure's utility service panel is equipped with a properly rated circuit breaker for use with the equipment inside. Refer to manufacturer's recommendations.
- Review and upgrade utility service panel circuit breaker requirements whenever the equipment within the enclosure is changed.
- Prior to installation, contact local utilities, local building maintenance departments, and cable/piping locator services to ensure that installation does not interfere with existing utility or building cables/piping.
- Do not exceed the output rating of equipment. Verify load requirements prior and during connection process.
- Prior to handling the batteries, touch a grounded metal object to dissipate any static charge that may have developed in your body.



The circuit board contains static-sensitive components. Please follow all appropriate ESD (Electro Static Discharge) handling practices. As an extra precaution, handle the USM2.5 with Acterna Embedded Transponder Module by the edges and keep fingers away from card edge connectors.

Battery Safety

Lead-acid batteries contain dangerous voltages, currents and corrosive material. Battery installation, maintenance, service and replacement must be performed by authorized personnel only.



Any gelled or liquid emissions from a Valve-Regulated lead-acid (VRLA) battery contain dilute sulfuric acid, which is harmful to the skin and eyes. Emissions are electrolytic, which are electrically conductive and corrosive.

Chemical Hazards

To avoid injury:

- Wear protective clothing (insulated gloves, eye protection, etc) whenever installing, maintaining, servicing, or replacing batteries.
- If any battery emission contacts the skin, wash immediately and thoroughly with water. Follow your company's approved chemical exposure procedures.
- If any battery emission contacts the eye, wash immediately and thoroughly with water for 10 minutes with pure water or a special neutralizing eye wash solution and seek immediate medical attention. Follow your company's approved chemical exposure procedures.
- Neutralize any spilled battery emission with the special solution contained in an approved spill kit or with a solution of 1 lb. bicarbonate of soda to 1 gal of water. Report chemical spill using your company's spill reporting structure and seek medical attention if necessary.
- Always replace batteries with those of an identical type and rating. Never install old or untested batteries.
- Do not charge batteries in a sealed container. Each individual battery should have at least 0.5 inches of space between it and all surrounding surfaces to allow for convection cooling.
- All battery compartments must have adequate ventilation to prevent an accumulation of potentially dangerous gas.

Maintenance Guidelines

The battery maintenance instructions listed below are for reference only. Battery manufacturer's instructions for transportation, installation, storage or maintenance take precedence over these instructions.

- To prevent damage inspect batteries every 3 months for:
 - Signs of battery cracking, leaking or swelling.* The battery should be replaced immediately by authorized personnel using a battery of the identical type and rating.
 - Signs of battery cable damage.* Battery cable should be replaced immediately by Authorized Personnel using replacement parts specified by vendor.
 - Loose battery connection hardware.* Refer to battery manufacturer's documentation for the correct torque and connection hardware for the application.
- Apply battery manufacturer's specified antioxidant compound on all exposed connections.
- Verify battery terminals and/or exposed connection hardware has not shifted within 2 inches of a conductive surface. Reposition batteries as necessary to maintain adequate clearance.
- Clean up any electrolyte (battery emission) in accordance with all federal, state, and local regulations or codes.

Recycling and Disposal Instructions



Spent or damaged batteries are considered environmentally unsafe. Always recycle used batteries or dispose of the batteries in accordance with all federal, state and local regulations.

1.1 Installation in an XM Series 2 Power Supply

1. Record the transponder address (located on the sheet metal of the front panel).
2. Open the power supply enclosure.



NOTE: Backup power will not be available while batteries are disconnected.

3. Set the battery breaker on the front of the power supply to the OFF position.
4. Unplug all connectors on the front of the power supply inverter module.
5. Loosen the thumb screws holding the inverter module into the power supply.
6. Slide the inverter module out far enough to unplug the ribbon cable at the back of the inverter module (fig A). Disengage the two latches holding the plug into the socket (fig. B), and remove the plug.
7. Slide the inverter module all of the way out of the power supply.
8. Remove the blanking plate and USM2 (if installed) from the inverter module.
9. Install the USM2.5 (refer to USM2.5 Operator's and Technical manual. P/N: 704-683-B0-xxx).

- 10(a). *For a USM2.5 with single ribbon cable socket (J2):* Attach one end of the 2-position ribbon cable to the connector (JP2) at the top of the transponder, and the other end to the connector on the USM2.5 (J2). (fig. C)

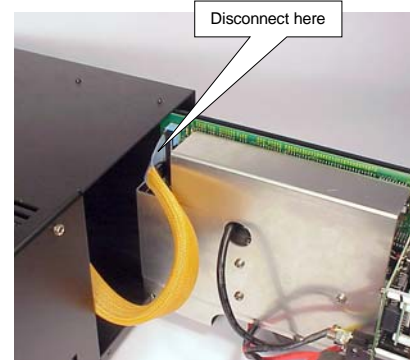

Fig. A

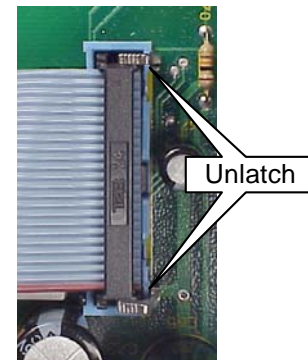

Fig. B

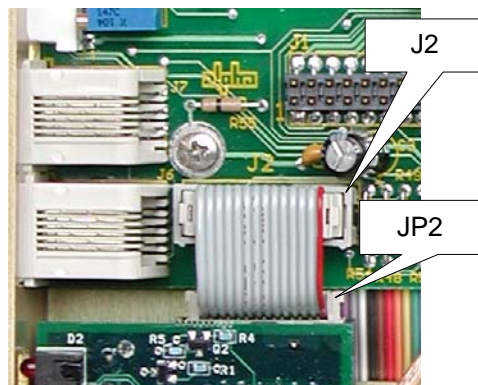

Fig. C; Two-Position Ribbon Cable Connection

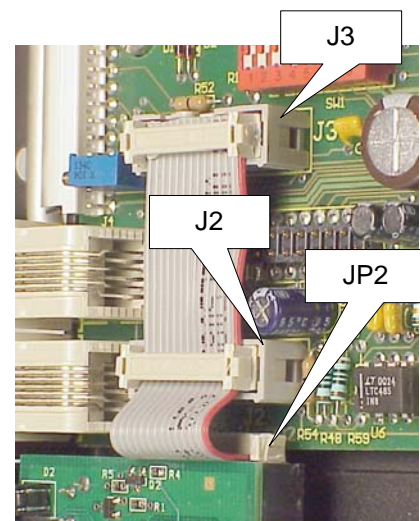

Fig. D; Three-Position Ribbon Cable Connection

1. Installation

1.1 Installation in an XM Series 2 Power Supply, *continued*

10(b). For a USM2.5 with two ribbon cable sockets (J2, J3):

Attach one end of the 3-position ribbon cable to the connector (JP2) at the top of the transponder, and the other two connectors to the USM2.5 (J2, J3). (fig. D)

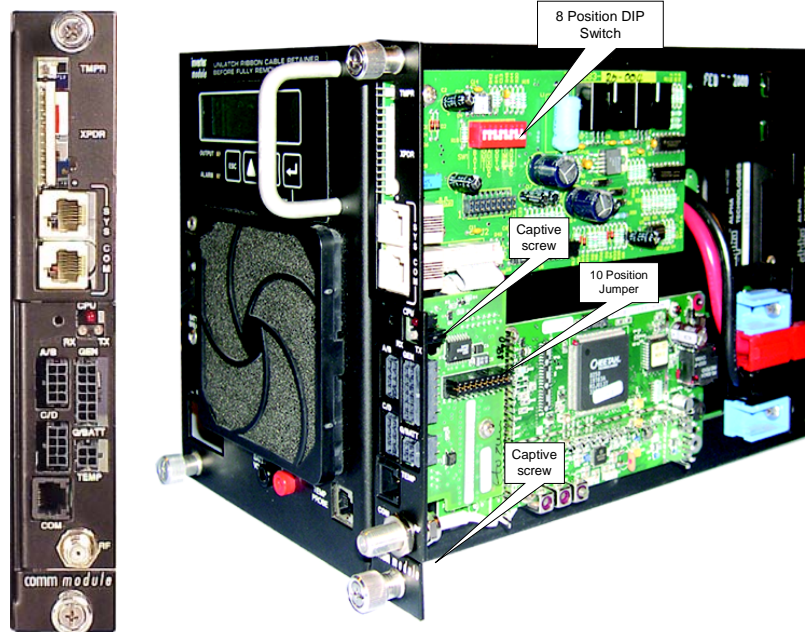

Figure 1-1 Transponder Installed

11. Using the two captive screws just behind the face plate, secure the transponder to the inverter module.
12. Verify that the 10-position jumper on the transponder is set to the correct battery pack voltage.
13. Verify that the 8-position DIP Switch on the USM2.5 is set correctly. Refer to the USM2.5 operators manual (Alpha p/n 704-683-B0).
14. Set the inverter module onto the guides, and slide it 1 or 2 inches into the power supply.
15. Reconnect the ribbon cable to the inverter module, and latch the two retaining clips over the ribbon cable plug.
16. Slide the inverter module fully into the power supply, and tighten the thumb screws. Set the BATTERY BREAKER to the ON position.
17. Verify after 10-30 seconds, the Smart Display on the power supply reads 'OPERATION NORMAL'.
18. Download Alarm Profile from CheetahNet to initiate appropriate mode of operation.
19. Verify that, after approx. 1 minute, the 'CPU' LED on the front of the transponder is blinking, if not, press the RESET button behind the hole next to the LEDs (see fig. 1-2).

1.2 Transponder Inputs and Outputs

The following section describes the input and output connections on the transponder. Refer to the sections indicated below for a brief description and pin-out of the connector.

- CPU LED Flashing: Normal operation, P-Code running.
 Solid: Initial start-up, R-Code running.
- RX LED Data is being received from the HEC (Head End Controller).
- TX LED Data is being sent to the HEC.

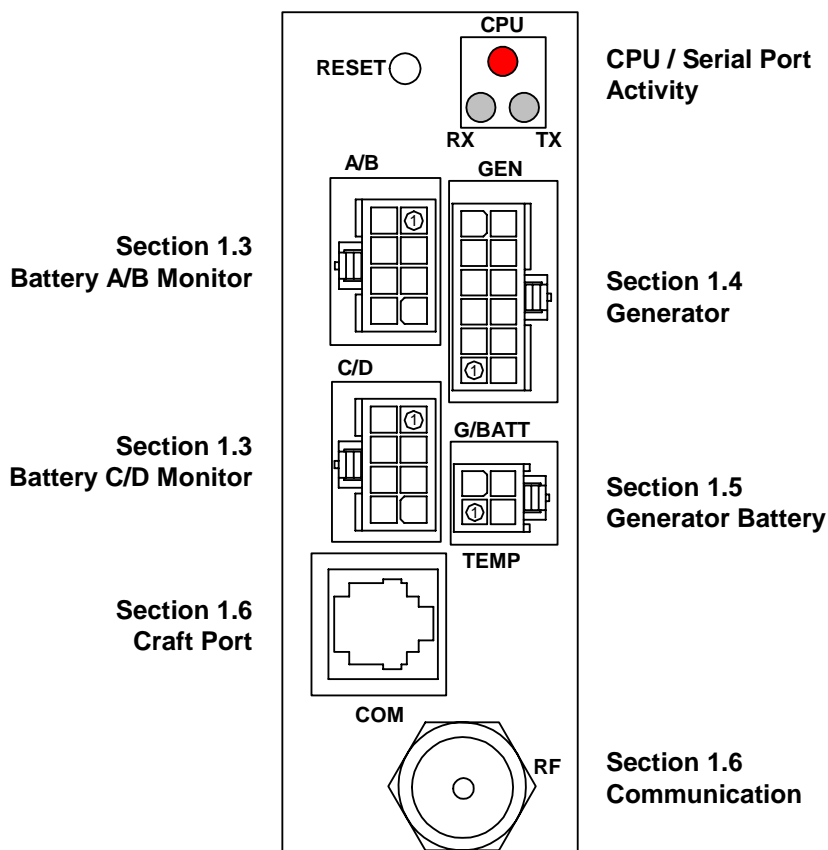

Figure 1-2 Input / Output Connections

1. Installation

1.3 Battery Monitor Connections

Refer to section 4 for wire kit part numbers.



WARNING: Verify that the 10 Position jumper on the transponder is set to the proper battery voltage prior to connecting the battery monitor wire kit.



NOTE: A maximum of 12 batteries can be monitored by the transponder.

Connector	Pin #	String Reference	Wire Label	CheetahNet Display (48V)
A/B	1	1A - (0Vdc)	A/B [C/D] NEG	
	2	1A + (+12Vdc)	Vbatt 1A [C] 12V	Battery #4 Vdc
	3	2A + (+24Vdc)	Vbatt 2A [C] 24V	Battery #3 Vdc
	4	3A + (+36Vdc)	Vbatt 3A [C] 36V	Battery #2 Vdc
	5	1B + (+12Vdc)	Vbatt 1B [D] 12V	Battery #8 Vdc
	6	2B + (+24Vdc)	Vbatt 2B [D] 24V	Battery #7 Vdc
	7	3B + (+36Vdc)	Vbatt 3B [D] 36V	Battery #6 Vdc
	8	4A + (+48Vdc) 4B + (+48Vdc)	Vbatt A/B [C/D] 48V	Battery #1 Vdc Battery #5 Vdc
C/D	1	1C - (0Vdc)	A/B[C/D] NEG	
	2	1C + (+12Vdc)	Vbatt 1A [C] 12V	Battery #11 Vdc
	3	2C + (+24Vdc)	Vbatt 2A [C] 24V	Battery #10 Vdc
	4	3C + (+36Vdc)	Vbatt 3A [C] 36V	Battery #9 Vdc
	5			
	6			
	7			
	8	4C + (+48Vdc)	Vbatt A/B [C/D] 48V	Battery #12 Vdc



NOTE: Only TWO 48V strings can be monitored when using a generator. DO NOT connect to the BATT C/D connector if using the generator option.

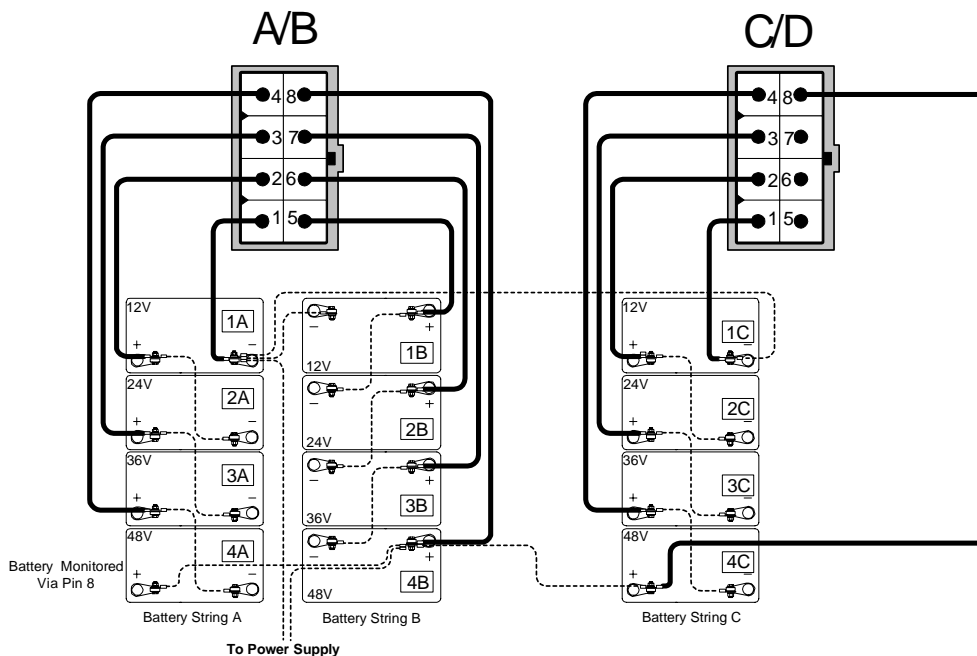

Figure 1-3 Battery Monitor Connections for three 48Vdc battery packs

1.3 Battery Monitor Connections, *continued*

Connector	Pin #	String Reference	Wire Label	CheetahNet Display (48V)
A/B	1	1A - (0Vdc)	A/B [C/D] NEG	
	2	1A + (+12Vdc)	Vbatt 1A [C] 12V	Battery #4 Vdc
	3	2A + (+24Vdc)	Vbatt 2A [C] 24V	Battery #3 Vdc
	4	3A + (+36Vdc)	Vbatt 3A [C] 36V	Battery #2 Vdc
	5	1B + (+12Vdc)	Vbatt 1B [D] 12V	Battery #8 Vdc
	6	2B + (+24Vdc)	Vbatt 2B [D] 24V	Battery #7 Vdc
	7	3B + (+36Vdc)	Vbatt 3B [D] 36V	Battery #6 Vdc
	8	4A + (+48Vdc)	Vbatt A/B [C/D] 48V	Battery #1 Vdc
		4B + (+48Vdc)		Battery #5 Vdc

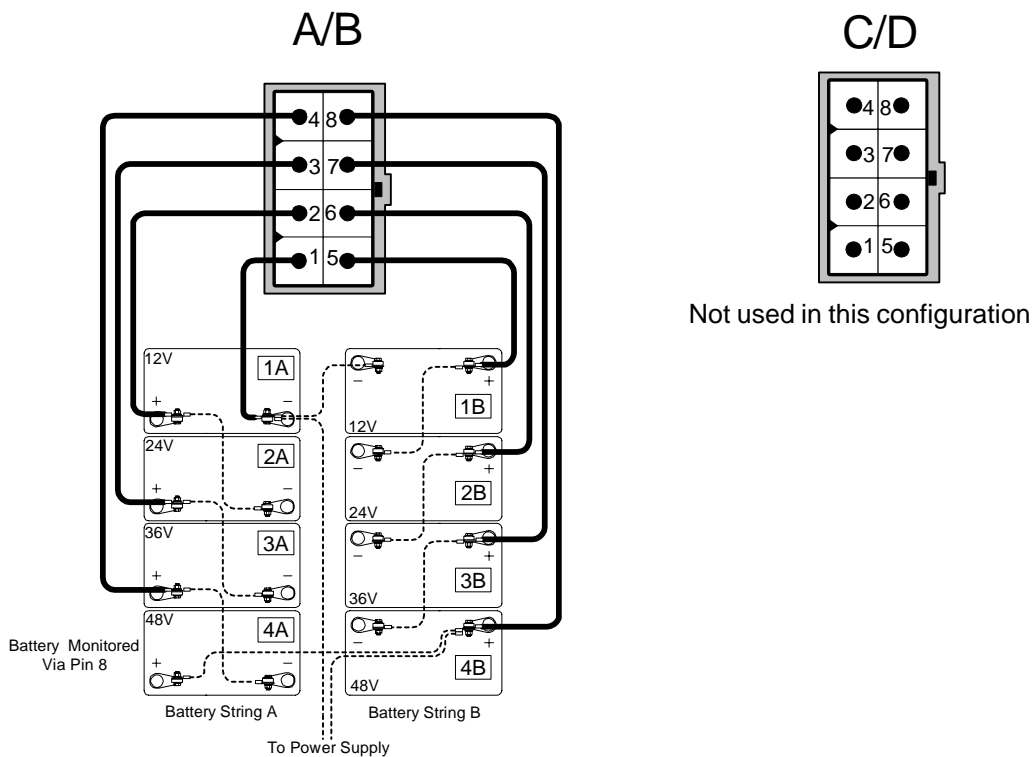

Figure 1-4 Battery Monitor Connections for two 48Vdc battery packs

1. Installation

1.3 Battery Monitor Connections, *continued*

Connector	Pin #	String Reference	Wire Label	CheetahNet Display (48V)
A/B	1	1A - (0Vdc)	A/B [C/D] NEG	
	2	1A + (+12Vdc)	Vbatt 1A [C] 12V	Battery #4 Vdc
	3	2A + (+24Vdc)	Vbatt 2A [C] 24V	Battery #3 Vdc
	4	3A + (+36Vdc)	Vbatt 3A [C] 36V	Battery #2 Vdc
	5			
	6			
	7			
	8	4A + (+48Vdc)	Vbatt A/B [C/D] 48V	Battery #1 Vdc

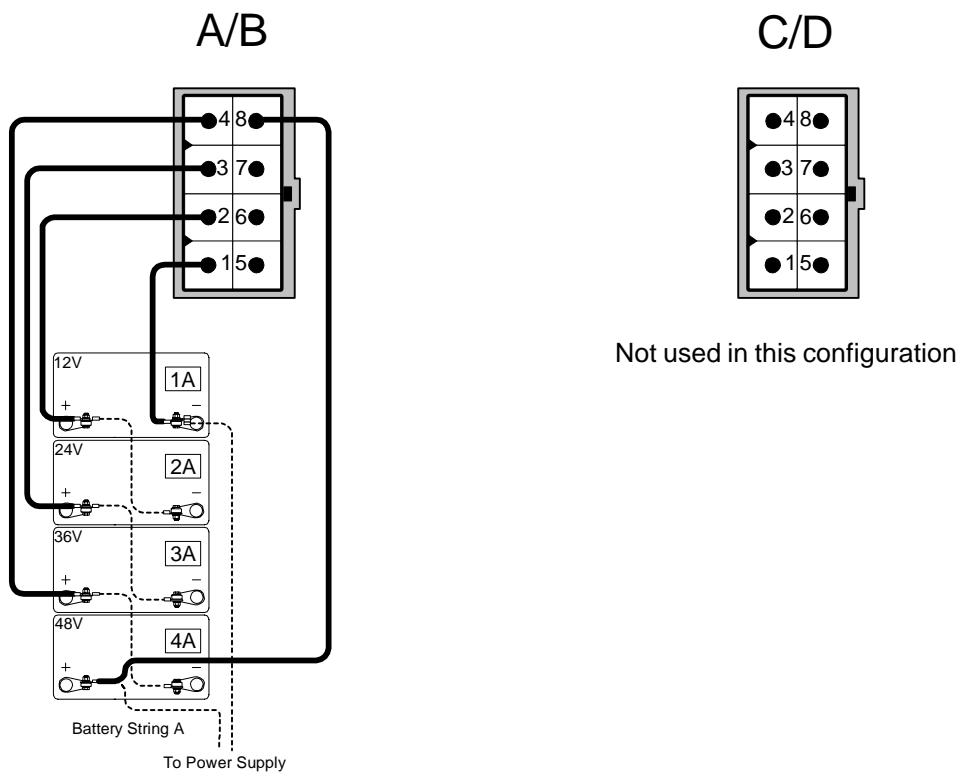

Figure 1-5 Battery Monitor Connections for one 48Vdc battery pack

1.3 Battery Monitor Connections, *continued*

Connector	Pin #	String Reference	Wire Label	CheetahNet Display (36V)
A/B	1	1A - (0Vdc)	A/B [C/D] NEG	
	2	1A + (+12Vdc)	Vbatt 1A [C] 12V	Battery #3 Vdc
	3	2A + (+24Vdc)	Vbatt 2A [C] 24V	Battery #2 Vdc
	4	3A + (+36Vdc)	Vbatt 3A [C] 36V	Battery #1 Vdc
	5			
	6			
	7			
	8			

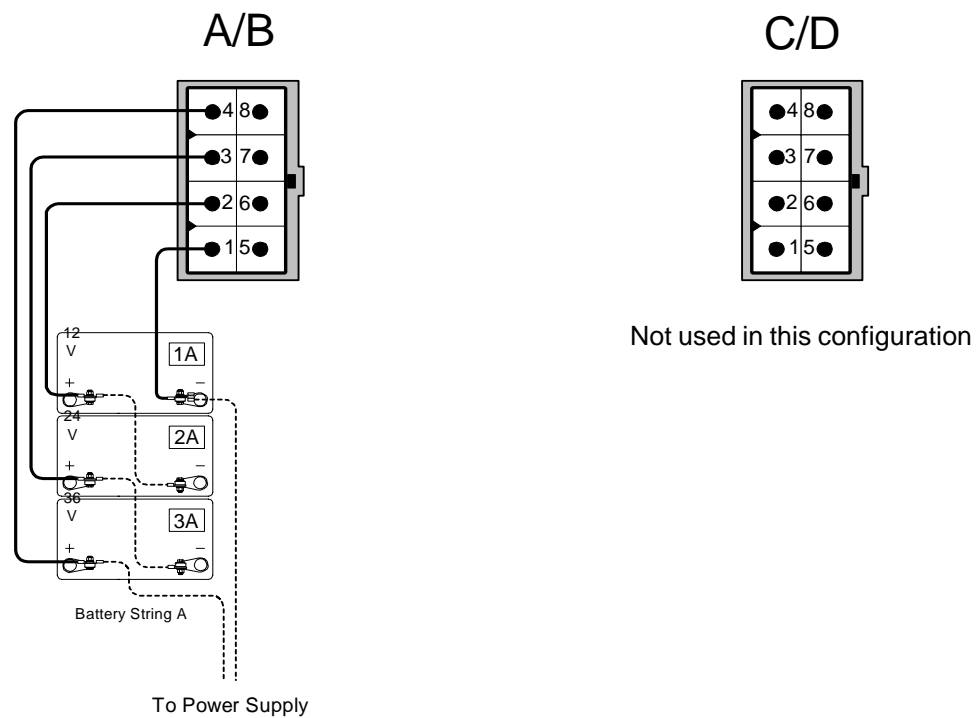

Figure 1-6 Battery Monitor Connections for one 36Vdc battery pack.

1. Installation

1.3 Battery Monitor Connections, *continued*

Connector	Pin #	String Reference	Wire Label	CheetahNet Display (36V)
A/B	1	1A - (0Vdc)	A/B [C/D] NEG	
	2	1A + (+12Vdc)	Vbatt 1A [C] 12V	Battery #3 Vdc
	3	2A + (+24Vdc)	Vbatt 2A [C] 24V	Battery #2 Vdc
	4	3A + (+36Vdc)	Vbatt 3A [C] 36V	Battery #1 Vdc
	5	1B + (+12Vdc)	Vbatt 1B [D] 12V	Battery #6 Vdc
	6	2B + (+24Vdc)	Vbatt 2B [D] 24V	Battery #5 Vdc
	7	3B + (+36Vdc)	Vbatt 3B [D] 36V	Battery #4 Vdc
	8			

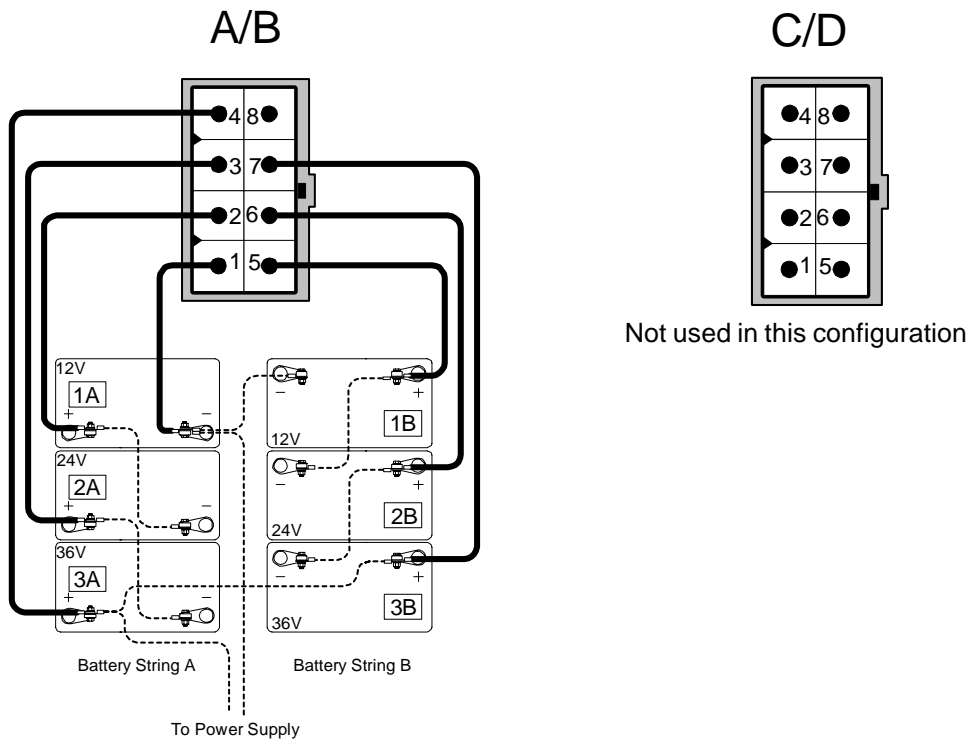

Figure 1-7 Battery Monitor Connections for two 36Vdc battery packs

1.3 Battery Monitor Connections, *continued*

Connector	Pin #	String Reference	Wire Label	CheetahNet Display (36V)
A/B	1	1A - (0Vdc)	A/B[C/D] NEG	
	2	1A + (+12Vdc)	Vbatt 1A [C] 12V	Battery #3 Vdc
	3	2A + (+24Vdc)	Vbatt 2A [C] 24V	Battery #2 Vdc
	4	3A + (+36Vdc)	Vbatt 3A [C] 36V	Battery #1 Vdc
	5	1B + (+12Vdc)	Vbatt 1B [D] 12V	Battery #6 Vdc
	6	2B + (+24Vdc)	Vbatt 2B [D] 24V	Battery #5 Vdc
	7	3B + (+36Vdc)	Vbatt 3B [D] 36V	Battery #4 Vdc
	8			
C/D	1	1C - (0Vdc)	A/B[C/D] NEG	
	2	1C + (+12Vdc)	Vbatt 1A [C] 12V	Battery #9 Vdc
	3	2C + (+24Vdc)	Vbatt 2A [C] 24V	Battery #8 Vdc
	4	3C + (+36Vdc)	Vbatt 3A [C] 36V	Battery #7 Vdc
	5			
	6			
	7			
	8			

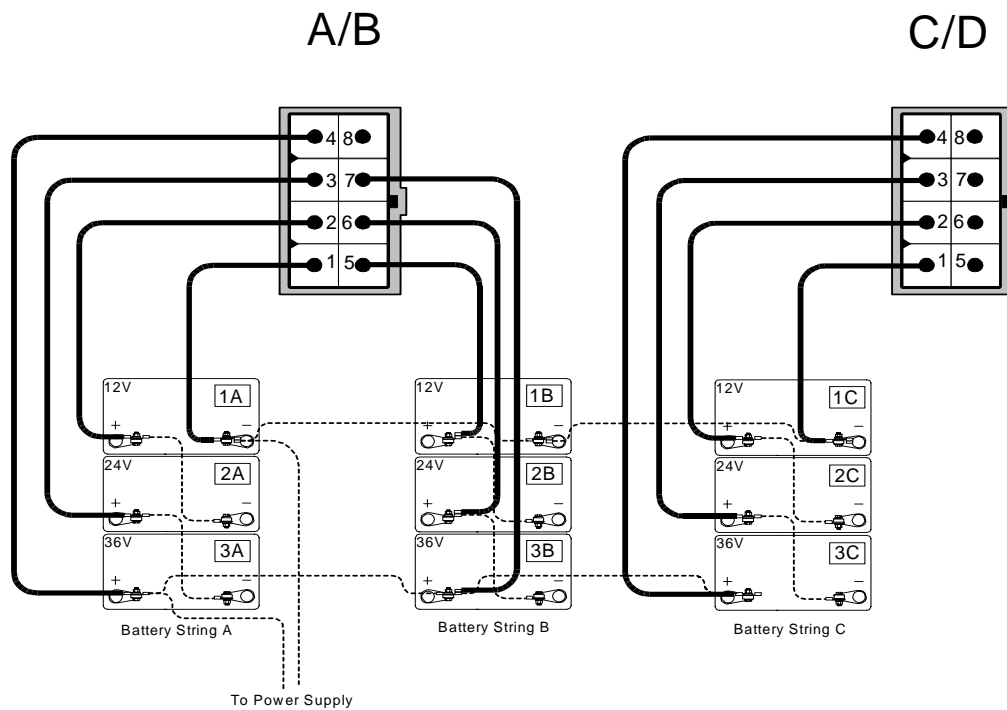

Figure 1-8 Battery Monitor Connections for three 36Vdc battery packs

1. Installation

1.3 Battery Monitor Connections, *continued*

Connector	Pin #	String Reference	Wire Label	CheetahNet Display (36V)
A/B	1	1A - (0Vdc)	A/B[C/D] NEG	
	2	1A + (+12Vdc)	Vbatt 1A [C] 12V	Battery #3 Vdc
	3	2A + (+24Vdc)	Vbatt 2A [C] 24V	Battery #2 Vdc
	4	3A + (+36Vdc)	Vbatt 3A [C] 36V	Battery #1 Vdc
	5	1B + (+12Vdc)	Vbatt 1B [D] 12V	Battery #6 Vdc
	6	2B + (+24Vdc)	Vbatt 2B [D] 24V	Battery #5 Vdc
	7	3B + (+36Vdc)	Vbatt 3B [D] 36V	Battery #4 Vdc
	8			
C/D	1	1C - (0Vdc)	A/B[C/D] NEG	
	2	1C + (+12Vdc)	Vbatt 1A [C] 12V	Battery #9 Vdc
	3	2C + (+24Vdc)	Vbatt 2A [C] 24V	Battery #8 Vdc
	4	3C + (+36Vdc)	Vbatt 3A [C] 36V	Battery #7 Vdc
	5	1D + (+12Vdc)	Vbatt 1A [D] 12V	Battery #12 Vdc
	6	1D + (+12Vdc)	Vbatt 2A [D] 24V	Battery #11 Vdc
	7	1D + (+12Vdc)	Vbatt 3A [D] 12V	Battery #10 Vdc
	8			



NOTE:

Only THREE 36V strings can be monitored when using a generator. DO NOT connect a fourth string to the BATT C/D connector if using the generator option.

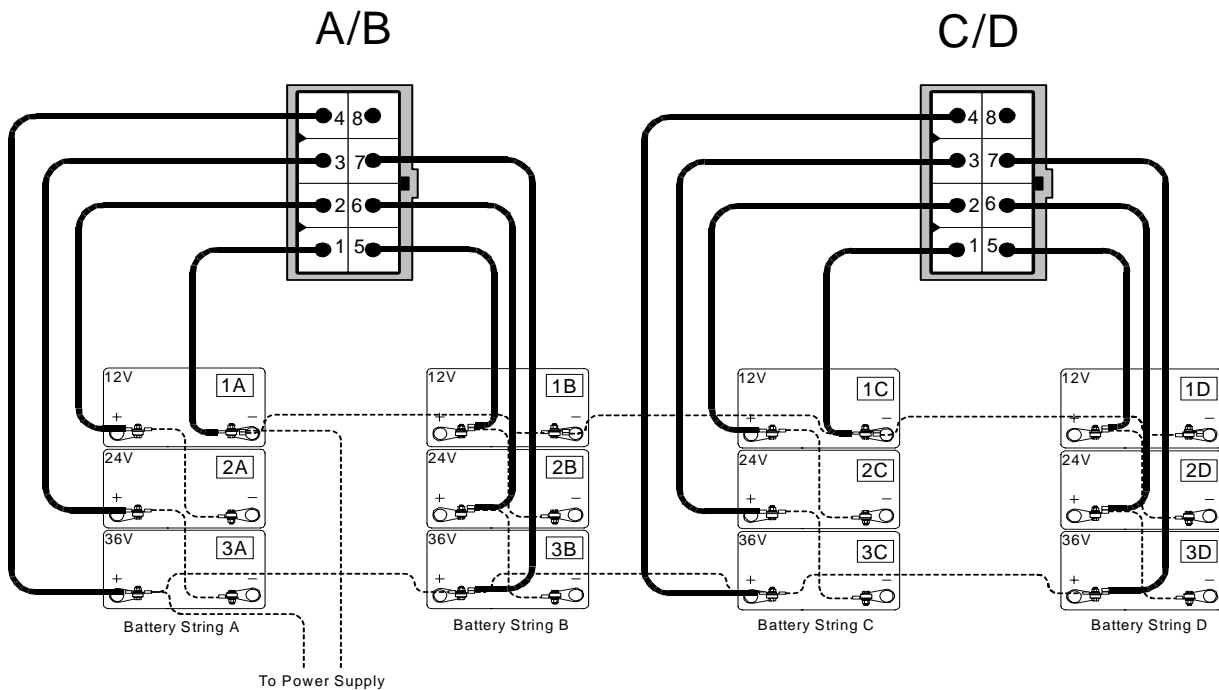

Figure 1-9 Battery Monitor Connections for four 36Vdc battery packs

1.4 Generator Connection

The Generator Connector provides the Transponder with alarms and status signals. Control signals can also be sent to the generator for test and Run / Stop. Refer to the ECM operation and maintenance manual for further information on the generator connections.

PIN #	Generator connection
1	APU Fail / Major Alarm
2	APU Minor Alarm
3	Engine Alarm
4	Gas Hazard Alarm
5	APU Test Fail Alarm
6	APU Enclosure Alarm
7	Engine Status
8	APU Enclosure Tamper
9	APU Signal Return / ground
10	APU Run / Test Command
11	Run / Test Command Return
12	No Connection

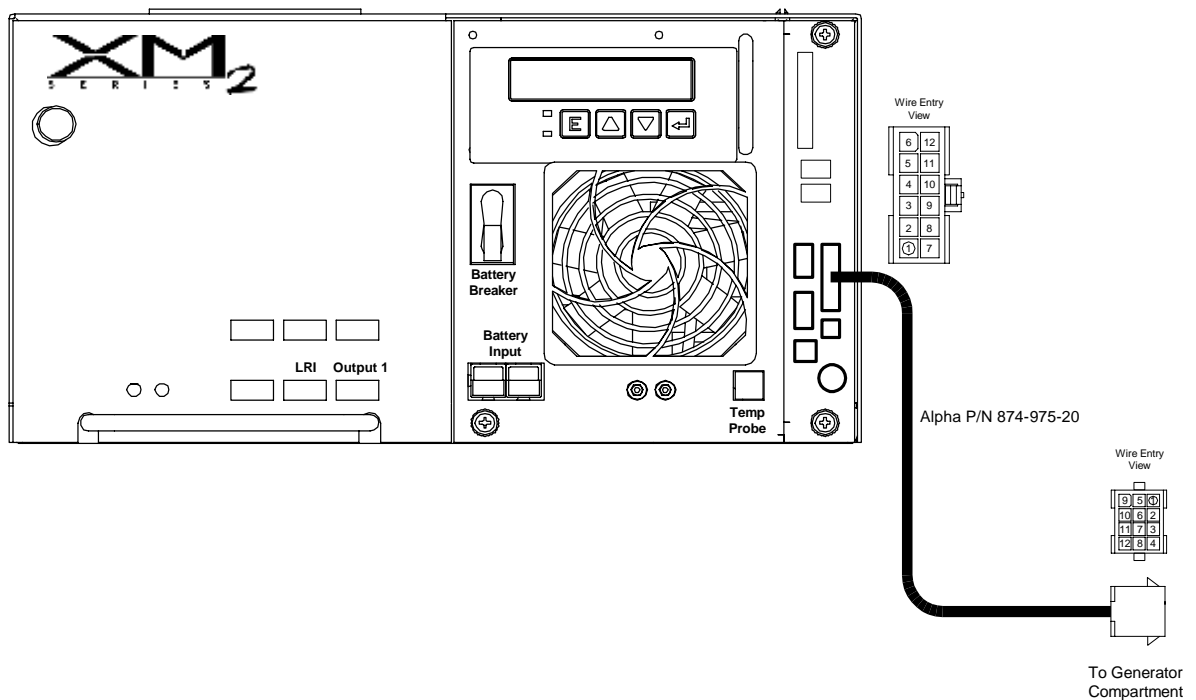

Figure 1-10 Generator monitor connections

1. Installation

1.5 Generator Ignition Battery Connection

The Generator Battery Connector provides the transponder with voltage information on the Ignition Battery and optional ambient temperature probe.

PIN #	Generator Connection
1	Ignition Battery Negative / Chassis Ground
2	Ignition Battery Positive
3	External Temperature Probe
4	Ignition Battery Negative / Chassis Ground

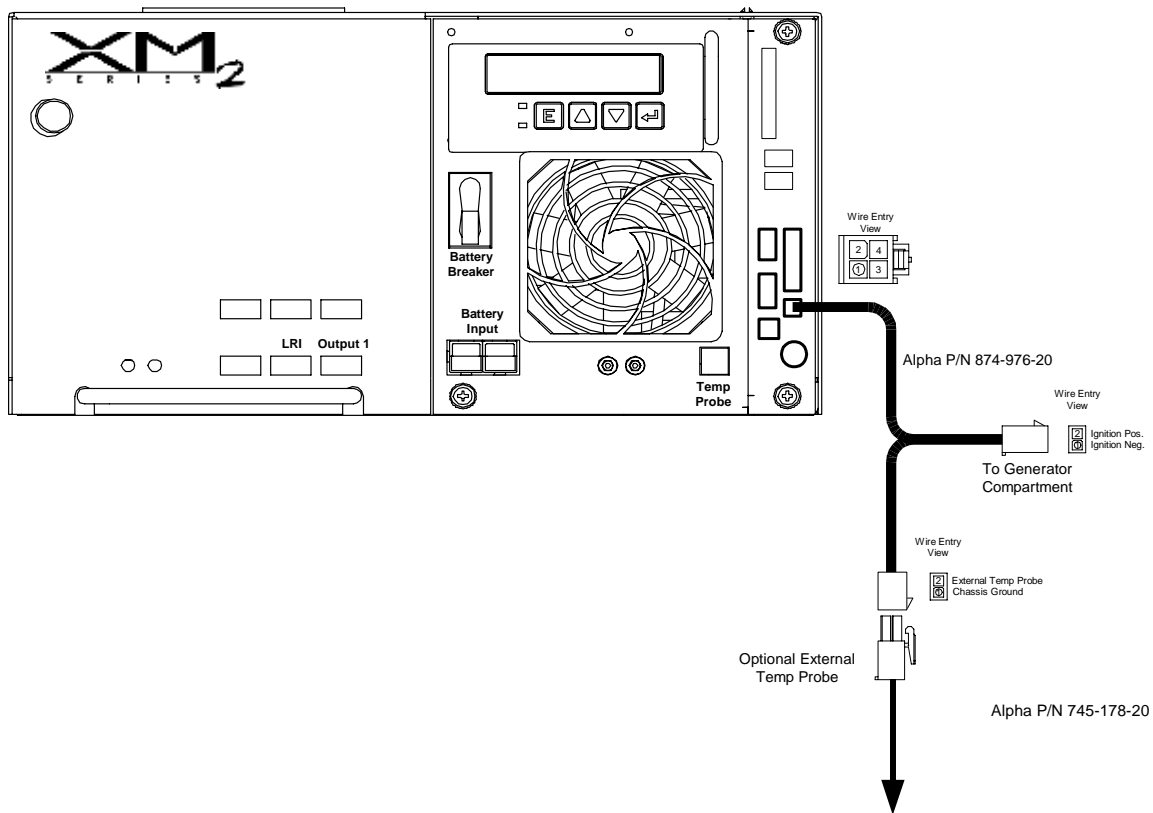

Figure 1-11 Generator Ignition battery connection

1.6 COMM and RF Connections

The COMM connector allows the technician to bypass the RF modulator and communicate with the transponder through a PC's RS-232 serial port.

The RF connector is the primary I/O port to the head-end modem.

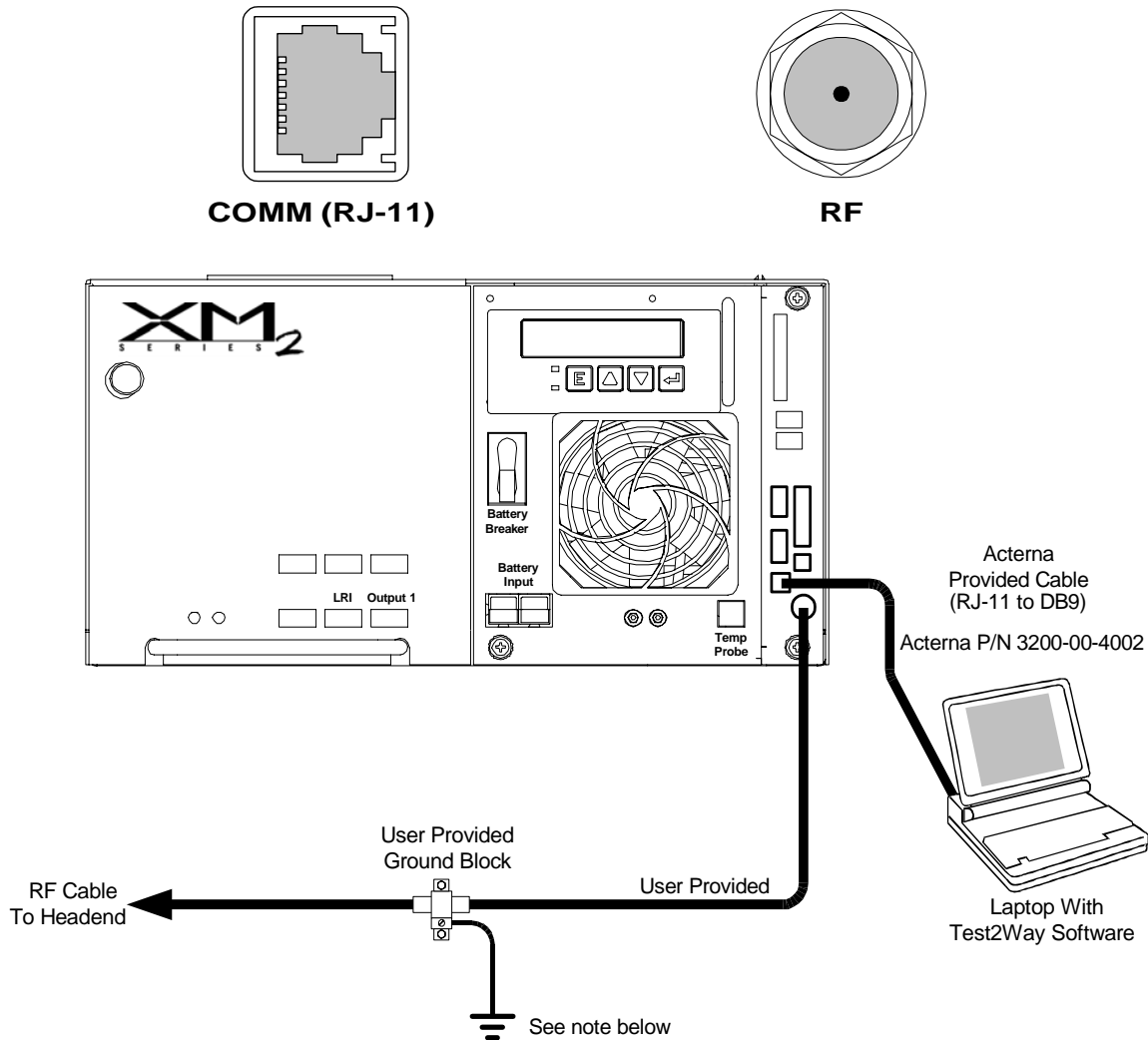

Figure 1-12 COMM / RF connections



NOTE: Wire from the ground block **MUST** be connected to the enclosure's grounding lug, or ground bar. Ensure that all connections are clean and bare. Coax **MUST** share the same ground as the power supply.

2. Specifications

2.1 Channel Parameters

Channel Description	Parameter name	Units	Maj Low	Min Low	Min Hi	Maj Hi	Note
Analog Inputs	Internal Temperature	(C)	0	10	50	60	
Analog Inputs	External Temperature	(C)	0	10	50	60	3
Analog Inputs	AC Output Current 1	(AMPS)	0.5	2	25	25.5	
Analog Inputs	AC Output Current 2	(AMPS)	0.5	2	25	25.5	
Analog Inputs	Battery Voltage #1	(VDC)	10	11	14.4	14.8	
Analog Inputs	Battery Voltage #2	(VDC)	10	11	14.4	14.8	
Analog Inputs	Battery Voltage #3	(VDC)	10	11	14.4	14.8	
Analog Inputs	Battery Voltage #4	(VDC)	10	11	14.4	14.8	
Analog Inputs	Battery Voltage #5	(VDC)	10	11	14.4	14.8	
Analog Inputs	Battery Voltage #6	(VDC)	10	11	14.4	14.8	
Analog Inputs	Battery Voltage #7	(VDC)	10	11	14.4	14.8	
Analog Inputs	Battery Voltage #8	(VDC)	10	11	14.4	14.8	
Analog Inputs	Battery Voltage #9	(VDC)	10	11	14.4	14.8	
Analog Inputs	Battery Voltage #10	(VDC)	10	11	14.4	14.8	
Analog Inputs	Battery Voltage #11	(VDC)	10	11	14.4	14.8	
Analog Inputs	Battery Voltage #12	(VDC)	10	11	14.4	14.8	
Analog Inputs	Generator Battery	(VDC)	10	11	14.4	14.8	
Analog Inputs	AC Output Voltage	(VAC)	50	55	95	98	
Analog Inputs	AC Input Voltage	(VAC)	95	100	125	128	2
Analog Inputs	AC Input Voltage	(VAC)	200	210	245	255	4
		Hi State	Lo State				
Digital input	Standby Mode	Normal	Standby				
Digital input	Tamper Switch	Open	Closed				
Digital input	Output Fail Alarm	Normal	Alarm				
Digital input	General Alarm	Normal	Alarm				1
Digital input	APU Test Fail	Alarm	Normal				1
Digital input	Engine Status	OFF	ON				1
Digital input	APU Fail / ECM	Alarm	Normal				1
Digital input	APU Response	Alarm	Normal				1
Digital input	Gas Hazard Alarm	Alarm	Normal				1
Digital input	APU Engine Alarm	Alarm	Normal				1
Digital input	Generator Enclosure	Open	Closed				1
Digital input	Generator Tamper	Closed	Open				1
Digital output	Standby ON / OFF	OFF	ON				
Digital output	Equalize ON / OFF	OFF	ON				
Digital output	Engine ON / OFF	OFF	ON				
Note 1 - Generator							
Note 2 - AC Input 120 VAC Models							
Note 3 - External Temperature							
Note 4 - AC Input 240 VAC Models							

Table 2-1 Channel Parameters

3.1 Important Troubleshooting Notes

Always troubleshoot communication problems before working on battery-related and/or generator-related problems. The embedded transponder runs off of the power supply's USM2.5 logic voltages, and does not require the sensing cables (from the batteries or the generator) to communicate.

1. USM2.5 Switch Set-up: The 8 position "DIP" switch on the USM2.5 board must be set correctly. See the complete chart in the *USM2.5 Status Monitor Operator's and Technical Manual P/N 704-683-B0-xxx*. Note that SW1-4 (the fourth switch from the front) must be turned ON when using an internal Acterna transponder.

USM2.5 Switch Settings for Embedded Acterna Transponders

XM2 Models	SW 1	SW 2	SW 3	SW 4	SW 5	SW 6	SW 7	SW 8
all XM2 -610 & -615; all XM2-910 & -915; XM2-1350 @ 75VAC or 90VAC	ON	ON	off	ON	off	ON	off	off
XM2-1350 @ 60VAC	ON	ON	ON	ON	off	ON	off	off
XM2-1350-48 @ 75VAC or 90VAC	off	off	off	ON	off	ON	off	off
XM2-1350-48 @ 60VAC; all XM2-922	off	off	ON	ON	off	ON	off	off

2. Transponder Address: The transponder address is the five (5) digit number printed on the sticker on the FRONT of the Embedded Transponder Assembly, above the "F" connector. *The address is not the printed circuit board serial number (typically in the format of 1B followed by six numbers) from the sticker on the PCB itself.* The address can be verified from the SOC (Systems Operation Center).
3. Transponder Driver: The correct Acterna device driver must be downloaded from the HEC to the transponder. The following is Acterna's list of device drivers for embedded (internal) transponders in Alpha Technologies XM2 power supplies, as of 17 October 2002.

Acterna Driver #	Battery Voltage	Battery Monitoring	Input / Utility Power Voltage	Generator	Supply
8028	36VDC	4 battery strings max	120VAC	none	single
8029	36VDC	3 battery strings max	120VAC	with generator	single
8030	48VDC	3 battery strings max	120VAC	none	single
8031	48VDC	2 battery strings max	120VAC	with generator	single
8033	36VDC	4 battery strings max	240VAC	none	single
8034	36VDC	3 battery strings max	240VAC	with generator	single
8035	48VDC	3 battery strings max	240VAC	none	single
8036	48VDC	2 battery strings max	240VAC	with generator	single
8037	48VDC	1 battery strings max	240VAC	with generator	dual

For technical support for cable products, contact Tollgrade at:
 Tollgrade Communications, Inc.
 7020 Professional Parkway
 Sarasota FL 34240
 TAC Phone: 941-373-6850 / 1-888-486-3510
 TAC FAX: 941-373-6885
 Email: cheetahsupport@tollgrade.com

3. Troubleshooting

3.1 Important Troubleshooting Notes, *continued*

If there are two power supplies in the same enclosure, make sure that the interface cable from the generator ECM is connected to the correct embedded transponder.

4. **Battery Voltage Jumper:** Verify that the battery voltage jumper block is in the correct position:
 - The jumper will be installed in the bottom position for 36VDC battery systems (shorting the bottom two rows of pins, and with the top row of pins exposed)
 - The jumper will be installed in the top position for 48VDC battery systems (shorting the top two rows of pins, and with the bottom row of pins exposed).Use *extreme* care when removing the jumper – lift the jumper only, don't pry the pin assembly off the PC board.
5. **Battery Voltage Sensing:** Verify the battery sensing cables are connected correctly – battery polarity is critical. The battery numbering / labeling conforms to the requirements of the SCTE HMS standard. (Refer to section 1.3, Battery Monitor Connections.) The battery numbering shown in Acterna's CheetahNet display will be as listed in the manual.
 - Each string is labeled A, B, C, or D, shown as "x" below. Not all battery sensing wires will be present in all harnesses. For example, in a 2 string system, there may only be one NEG wire - connect to either string's battery # 1 negative post.

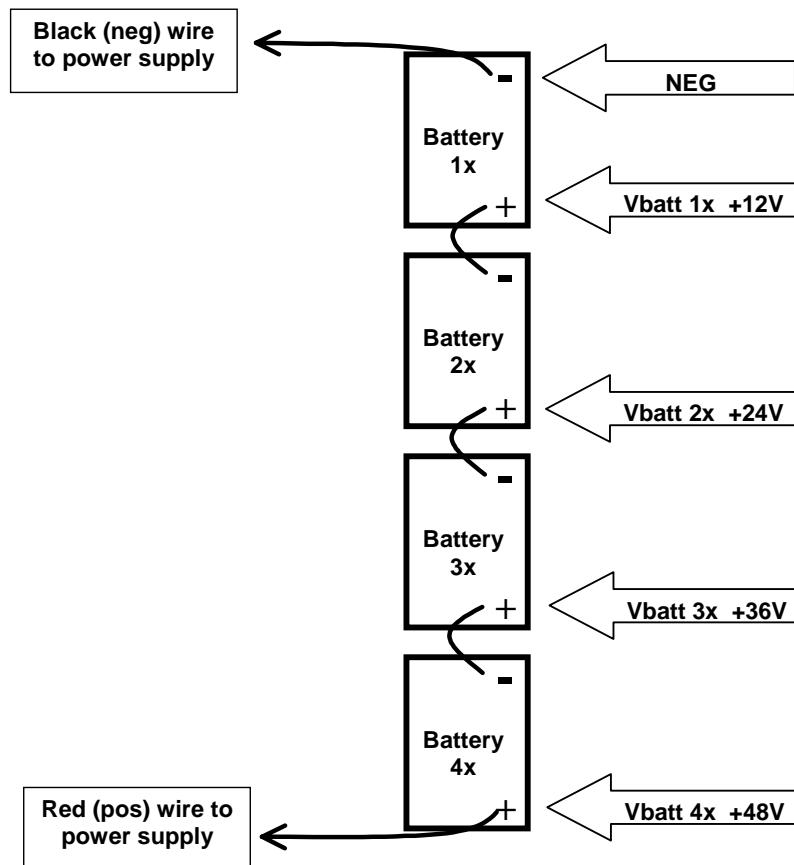

Figure 3-1 Battery String Example

3.2 Troubleshooting Specifics and Testing

Troubleshooting

Problem: Missing parts or shipping damage.

Solution: Contact Alpha Technologies at:

Alpha Technologies, Inc.
3767 Alpha Way
Bellingham, WA. 98226
360-647-2360

Problem: Unable to communicate with transponder.

Solution: Check port assignments, cables, and RPS name / port.

Problem: Incorrect device type selected when adding unit.

Solution: Check the device type in the Device Configuration screen (CheetahNet).

Problem: Incorrect address.

Solution: Verify that address in the Device Configuration screen (CheetahNet) matches address on front panel. If they do not match, contact network operations center technician.

Problem: Incorrect controller frequencies.

Solution: Verify that frequencies on the HEC port configuration screen match address on front panel. If they do not match, contact network operations center technician.

Problem: Incorrect signal level.

Solution: Verify forward and return signals are within Acterna specifications. Padding may have to be added or removed.

Problem: Unable to communicate with CheetahNet.

Solution: Verify that the transponder is not in 'R' mode. Use laptop computer running 'Test2Way' to verify what code is running.

If the CPU LED is on steady, unit is in 'R-code', if the LED is flashing, unit is in 'P-code' (normal operation).

Testing

All testing shall be performed via Acterna's CheetahNet and Test2way software. Refer to software manufacturer's instructions.

4. Part Numbers

4.1 Cable Kit Options

Combination Kits

<u>Part Number</u>	<u>Description</u>
745-181-20	Combo Batt Sense Kit, 1x36V, w/ Gen Interface
745-197-23	Combo Batt Sense Kit, 2x36V, w/ 35' Ext.
745-197-22	Combo Batt Sense Kit, 3x36V, w/ 2x35' Ext.
745-198-21	Combo Batt Sense Kit, 3x36V, 1 @ 6', 2 @ 9'
745-180-20	Combo Batt Sense Kit, 4x36V, w/ 2x35' Ext.
745-182-20	Combo Batt Sense Kit, 4x36V, 2 @ 6', 2 @ 9'
745-246-20	Combo Batt Sense Kit, 1x48V, w/ Gen Interface
745-197-20	Combo Batt Sense Kit, 2x48V, w/ 35' Ext.
745-197-21	Combo Batt Sense Kit, 3x48V, w/ 2x35' Ext.
745-198-20	Combo Batt Sense Kit, 3x48V, 2 @ 6', 1 @ 9'
745-245-20	Combo Generator Xpdr Wire Kit

Individual Kits

<u>Part Number</u>	<u>Description</u>
874-842-21	Wire Kit, Battery Sense, 1x36V, 6'
874-842-20	Wire Kit, Battery Sense, 2x36V, 6'
874-842-27	Wire Kit, Battery Sense, 1x36V, 9'
874-842-28	Wire Kit, Battery Sense, 2x36V, 9'
874-841-21	Wire Kit, Battery Sense, 1x48V, 6'
874-841-20	Wire Kit, Battery Sense, 2x48V, 6'
874-841-25	Wire Kit, Battery Sense, 1x48V, 9'
874-841-24	Wire Kit, Battery Sense, 2x48V, 9'
874-841-23	Extension Wire Kit, Battery Sense, 6'
874-841-22	Extension Wire Kit, Battery Sense, 35'
874-975-20	Emb. Transponder Generator Interface Wire Kit
874-976-20	Emb. Transponder Ignition Battery Wire Kit

Ribbon Cable Kits (for spare parts or replacement)

<u>Part Number</u>	<u>Description</u>
874-992-20	Wire Assy, Ribbon Cable, 14p, Int/Ext, USM2.5
875-045-20	Wire Assy, Ribbon Cable, 14p, 3 Skt, Int/Ext, USM2.5

Dual Power Supply Monitor Conversion Kit

<u>Part Number</u>	<u>Description</u>
745-238-20	Kit, 1Xpndr, 2Pwr Sply, Interconn, XMS2

Table 4-1 Cable kit part numbers

Power

Alpha Technologies

Corporate

Alpha Technologies
3767 Alpha Way
Bellingham, WA 98226

USA

Tel: (360) 647-2360
Fax: (360) 671-4936
Web: www.alpha.com

Alpha Technologies Ltd.
4084 McConnell Court
Burnaby, BC, V5A 3N7

CANADA

Tel: (604) 430-1476
Fax: (604) 430-8908

Alpha Technologies
Europe Ltd.
Cartel Business Estate
Edinburgh Way
Harlow, Essex CM20 2TT
UNITED KINGDOM
Tel: +44-1279-422110
Fax: +44-1279-423355

Alpha Technologies
Hansastrasse 8
D-91126 Schwabach
GERMANY
Tel: +49-9122-79889-0
Fax: +49-9122-79889-21

Alphatec
339 St. Andrews Street
Suite 101
Andrea Chambers
Limassol, Cyprus
CYPRUS
Tel: +357-25-375675
Fax: +357-25-359595

Alpha Technologies
Unit R5-R7 Regents Park
Estate
Corner Park Rd and Prince's
Rd East
Regents Park, NSW 2143
AUSTRALIA
Tel: +61-2-9722-3320
Fax: +61-2-9722-3321