

VMX Standby Power Supply



Technical Manual VMX Series Standby Power Supply

Effective: October, 2007

Power Alpha Technologies ®

VMX Standby Power Supply

017-940-B0-001, Rev A

Effective Date: October, 2007
Copyright© 2007
Alpha Technologies, Inc.

member of The  Group™

 **NOTE:**

Photographs contained in this manual are for illustrative purposes only. These photographs may not match your installation.

 **NOTE:**

Operator is cautioned to review the drawings and illustrations contained in this manual before proceeding. If there are questions regarding the safe operation of this powering system, please contact Alpha Technologies or your nearest Alpha representative.

 **NOTE:**

Alpha shall not be held liable for any damage or injury involving its enclosures, power supplies, generators, batteries, or other hardware if used or operated in any manner or subject to any condition not consistent with its intended purpose, or is installed or operated in an unapproved manner, or improperly maintained.

Notice of FCC Compliance

Per FCC 47 CFR 15.21:

Changes or modifications not expressly approved by the party responsible for compliance could void the user's authority to operate the equipment.

Per FCC 47 CFR 15.105:

This equipment has been tested and found to comply with the limits for a Class A digital device, pursuant to part 15 of the FCC Rules. These limits are designed to provide reasonable protection against harmful interference when the equipment is operated in a commercial environment. This equipment generates, uses, and can radiate radio frequency energy and, if not installed and used in accordance with the instruction manual, may cause harmful interference to radio communications. Operation of this equipment in a residential area is likely to cause harmful interference in which case the user will be required to correct the interference at their own expense.

Contact Alpha Technologies: www.alpha.com

or

For customer service (7 AM to 5 PM, Pacific Time), call: **1-800-863-3930**

For complete technical support, call: **1-800-863-3364**

7 AM to 5 PM, Pacific Time, or 24/7 emergency support

In the UK call: **+44 0 1279 501110**

In Germany call: **+49 9122 79889 0**

To report errors in this document, send an email to:

Techpubs@alpha.com

Table of Contents

Safety Notes.....	7
Utility Power Connection Notes	9
Signal Ground.....	11
1.0 Introduction to the VMX Power Supply	12
1.1 Connections Overview	13
1.2 Inverter Overview	14
1.3 Optional Status Monitoring Modules	15
1.4 Optional Features	16
2.0 Theory of Operation.....	17
2.1 AC (Line) Operation.....	17
2.2 Standby Operation.....	17
2.3 Charger Operation	18
3.0 Installation.....	20
3.1 Installation Procedure	21
3.2 Service Power Inserter Connections.....	22
3.3 Installing the Coax Cable Connector Outputs.....	25
4.0 Configuration	26
4.1 Micro Board Setup	26
4.2 AC Output Voltage Reconfiguration	27
5.0 Operation.....	28
5.1 Start-up and Test.....	28
5.2 Smart Display.....	31
5.2.1 Operation Normal.....	33
5.2.2 Additional Information Display.....	34
5.2.3 Setup Menu.....	35
5.2.4 Alarm Indications.....	38
5.2.5 Control Panel LEDs.....	40
5.2.6 Detailed Menu Structure and Navigation	41
5.3 Smart Display Glossary	43
5.4 Automatic Performance Test.....	45

5.5	Providing Power via External Source.....	46
5.5.1	DC Powering	46
5.5.2	AC Powering	46
5.5.3	Using a Truck-mounted Inverter or Generator	47
5.6	Resumption of Utility Power.....	48
6.0	VMX Power Supply Maintenance	49
6.1	Check Battery Open Circuit Voltage	49
6.2	System Information	49
6.3	Check Battery Voltage Under Load.....	50
6.4	Check Battery Charger Voltage	51
6.5	Check Battery Terminals and Connecting Wires.....	51
6.6	Check Output Voltage	51
6.7	Check Output Current.....	51
6.8	Replacing the Metal Oxide Varistors.....	52
6.9	Maintenance Log	53
7.0	Specifications.....	54
7.1	Safety and EMC Compliance.....	55
8.0	Troubleshooting	56
8.1	Return/Repair Information.....	56
8.2	Parts Ordering Instructions	56
8.3	Emergency Shutdown.....	57

List of Figures and Tables

Fig. 1-1, VMX Power Supply	12
Fig. 1-2, VMX Terminal Block Overview	13
Fig. 1-3, Inverter Overview	14
Fig. 2-1, Charger Modes.....	18
Fig. 2-2, VMX Block Diagram	19
Fig. 3-1, SPI Cover Removal.....	22
Fig. 3-2, Coaxial Cable Insertion and Securing.....	22
Fig. 3-3, Cover Replaced, SPI Switched On	23
Fig. 3-4, SPI Grounding Lug.....	23
Fig. 3-5, Enclosure Ground Bar.....	23
Fig. 3-6, Wire/Connector Assembly	23
Fig. 3-7, SPI to Output 1-4 Connection	24
Fig. 4-1, Micro Board Settings	26
Fig. 4-2, Transformer Output Tap Connector	27
Fig. 5-1, Configuration Screen.....	28
Fig. 5-2, Smart Display	31
Fig. 5-3, Additional Info Display	34
Fig. 5-4, Setup Menu Display	37
Fig. 5-5, Smart Display LEDs	40
Fig. 6-1, MOV Removal.....	52
Fig. 6-2, MOV Replacement.....	52
Table 5-1, Setup Menu Parameters.....	36
Table 5-2, Major Alarms.....	39
Table 5-3, Minor Alarms.....	39

Safety Notes

Review the drawings and illustrations contained in this manual before proceeding. If there are any questions regarding the safe installation or operation of this product, contact Alpha Technologies or the nearest Alpha representative. Save this document for future reference.

To reduce the risk of injury or death, and to ensure the continued safe operation of this product, the following symbols have been placed throughout this manual. Where these symbols appear, use extra care and attention.

ATTENTION:

The use of ATTENTION indicates specific regulatory/code requirements that may affect the placement of equipment and /or installation procedures.



NOTE:

A NOTE provide additional information to help complete a specific task or procedure.



CAUTION!

The use of CAUTION indicates safety information intended to PREVENT DAMAGE to material or equipment.



WARNING!

WARNING presents safety information to PREVENT INJURY OR DEATH to the technician or user.

Safety Precautions

- Only qualified personnel may service the VMX Power Supply.
- The VMX shall be installed in an appropriate enclosure in accordance with the requirements of IEC 60364-4-482.
- Verify the voltage requirements of the equipment to be protected (load), the AC input voltage to the power supply (line), and the output voltage of the system prior to installation.
- Equip the utility service panel with a properly rated circuit breaker for use with this power supply.
- When connecting the load, DO NOT exceed the output rating of the power supply.
- Always use proper lifting techniques whenever handling the power supply or batteries.
- The VMX Power Supply contains more than one live circuit! Even though AC voltage is not present at the input, voltage may still be present at the output.
- If batteries are being stored prior to installation, charge at least once every three months to ensure optimum performance and maximum battery service life.
- To reduce the chance of spark, and wear on the connectors, always switch the inverter's battery circuit breaker off before connecting or disconnecting the battery pack.
- The battery pack, which provides backup power, contains dangerous voltages. Only qualified personnel should inspect or replace batteries.
- In the event of a short circuit, batteries present a risk of electrical shock and burns from high current. Observe proper safety precautions.
- Always wear protective clothing, insulated gloves and eye protection (safety glasses or face shield) whenever working with batteries.

Safety Precautions, continued

- Do not allow live battery wires to contact the enclosure chassis. Shorting battery wires can result in a fire or possible explosion.
- Always replace batteries with those of an identical type and rating. Never install old or untested batteries.
- Avoid using uninsulated tools or other conductive materials when handling batteries or working inside the enclosure.
- Remove all rings, watches and other jewelry before servicing batteries.
- Spent or damaged batteries are environmentally unsafe. Always recycle used batteries. Refer to local codes for proper disposal of batteries.

Battery Safety Notes

- Always refer to the battery manufacturer's recommendation for selecting correct "FLOAT" and "ACCEPT" charge voltages. Failure to do so can damage the batteries.
- Verify the VMX battery charger's "FLOAT" and "ACCEPT" voltage settings. See Section 5.2.3, Setup Menu.
- Batteries are temperature sensitive. During extremely cold conditions, a battery's charge acceptance is reduced and requires a higher charge voltage. During extremely hot conditions, a battery's charge acceptance is increased and requires a lower charge voltage. To compensate for changes in temperature, the battery charger is temperature compensating.
- If the batteries appear to be overcharged or undercharged, first check for defective batteries and then verify the correct charger voltage settings.
- To ensure optimum performance, inspect batteries every three to six months for signs of cracking, leaking, or unusual swelling (note that some swelling is normal).
- Check battery terminals and connecting wires. Clean battery terminal connectors periodically and torque to manufacturer's specifications. Spray the terminals with an approved battery terminal coating such as NCP-2.



NOTE:

If installed, disconnect the AlphaGuard (AG-CMT) prior to measuring battery voltage.



NOTE:

Even with a AG-CMT present in the system, any battery which fails the 0.3V load test *must be replaced with an identical type of battery.*

- Check battery voltages UNDER LOAD. Use a load tester if available. Differences between any battery in the set should not be greater than 0.3Vdc.
- Refer to the battery manufacturer's recommendation for correct charger voltages.
- Number the batteries (1, 2, 3, etc.) inside the enclosure for easy identification (refer to the appropriate enclosure installation guide).
- Establish and maintain a battery maintenance log (see Section 6.9).



NOTE:

Always verify proper polarity of cables before connecting the batteries to the power module. The batteries are clearly marked for polarity. If the cables become interchanged at the batteries the battery breaker will trip.

Utility Power Connection Notes

ATTENTION:

Connecting to the utility should be performed only by qualified service personnel and in compliance with local electrical codes. Connection to utility power must be approved by the local utility before installing the power supply.

ATTENTION:

UL and NEC require that a service disconnect switch (UL listed) be provided by the installer and be connected between the power source and the VMX Power Supply. Connection to the power supply must include an appropriate service entrance weather head.



NOTE:

In order to accommodate the high-inrush currents normally associated with the start-up of ferroresonant transformers (400A, no-trip, first-half cycle), either a “high-magnetic” or HACR (Heating, Air Conditioning, Refrigeration) trip breaker must be used. Do not replace these breakers with a conventional service entrance breaker. Alpha recommends ONLY Square D breakers because of increased reliability in this powering application. High-magnetic Square D circuit breakers and BBX option (UL Listed service entrance) are available from Alpha Technologies.

Description	Alpha P/N	Square D Part Number
230V Installation — HACR (15A)	470-224-10	QO215
BBX — External Service Disconnect	020-085-10	QO2-4L70RB
BBX — External Service Disconnect	020-141-10	QO8-16L100RB

VMX Line Cord Options	Alpha P/N
Line Cord,3C, #14, SCHUKO/320 C19 RECT, 1M (EU)	875-432-10
Line Cord, 3C, #14, SCHUKO/IEC 320 C19 REPT, 2.5M (EU)	875-433-10
Line Cord,3C, #14, BS546/IEC 320 C19 RCPT, 1M (India)	875-434-10
Line Cord,3C, #14, BS1363/IEC 320 C19 RCPT, 2M (UK)	875-435-10
Line Cord,3C, CHN/IEC 320 C19 RCPT, 1M (China)	875-436-10
Line Cord, 3-conductor, 12AWG, NEMA 6-15P (US)	875-471-10

Utility Power Connection Notes

ATTENTION:

In most cases, the following configurations qualify for service entrance use when wiring a duplex receptacle to a service disconnect. Other codes may also apply. Always contact your local utility to verify that the wiring conforms to applicable codes.

240Vac Service Entrance, VMX 225V, U.S. Domestic Models

These configurations are equipped with a 240Vac duplex receptacle to provide power to the power supply and peripheral equipment. The receptacle, NEMA 6-15R, is protected by a single, 2-pole, common trip 15A circuit breaker located inside the service entrance. Wiring is typical 14AWG per NEC code, and a grounding clamp, located on the enclosure, facilitates dedicated grounding.



NOTE:

To bond the box to a neutral plate, use the long green bonding screw provided (Alpha P/N 523-011-10).

220, 230, 240Vac Service Entrance, VMX 225V, International Models

Typical 220, 230, 240Vac 15A Service Entrance Wiring, International

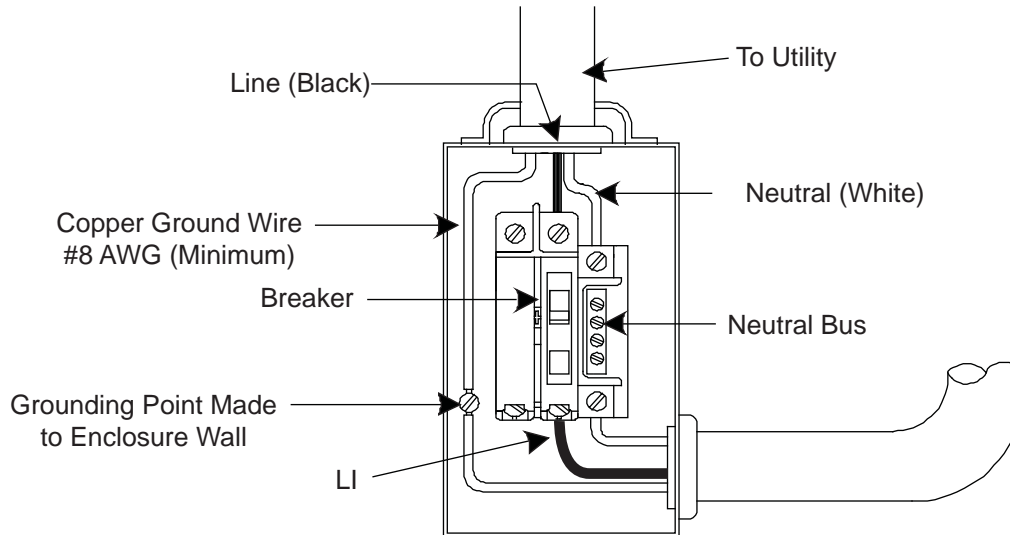

Grounding Connection Notes

In order to provide a ready, reliable, source of backup power, it is necessary to establish a grounding system that provides for the safety of service personnel and for the proper operation and protection of equipment within the network.

Safety Ground

The safety ground is a two-part system. The first part is a return path for stray current back to the input breaker, and the second is a return path from the Alpha enclosure to a second ground rod.

Typically, the utility ground provides a return path to the input breaker or fuse panel by means of a connection to an appropriate driven ground rod at the base of the power pole. This path must meet all local and national standards and regulations.

The second part of the safety ground arrangement is the ground path between the Alpha enclosure and a second ground rod located at least six feet away from the driven ground rod at the power pole. The second ground rod and enclosure are connected via #6AWG solid copper wire buried at a depth of 8 to 12 inches. The wire is connected to a ground lug on the back of the cabinet (for pole-mounted enclosures), or to a ground lug inside the cabinet (for ground-mounted enclosures). Connection to the ground rod is made with a listed grounding clamp suitable for direct burial, or by exothermic weld. Normally it is specified that the impedance of this ground can be no greater than 25 ohms at 60Hz. However, if dual ground rods are installed approximately eight feet apart, it is not necessary to measure the impedance of the ground rods (it is assumed that the impedance specification is met).

Signal Ground

For proper operation, the Service Power Inserter (SPI) must be securely grounded to the enclosure chassis. For systems utilizing ESM/DSM status monitoring, the coax drop ground connection is made through a separate chassis ground block (Alpha P/N 162-028-10).

Strike (Lightning) Ground

Lightning strikes, grid switching, or other aberrations on the power line all have the potential to cause “fast rise-time currents” that can cause damage to the powering system. Without a low-impedance path to ground, the current, while traveling through wires of varying impedance, can produce high voltages that will damage the powering equipment. The most viable method available to protect the system from damage is to divert these unwanted fast rise-time currents along a low-impedance path to ground. A low-impedance path to ground will prevent these currents from reaching high voltage levels and posing a threat to equipment. The single-point grounding system provides a low-impedance path to ground, and the key to its success is the proper bonding of the ground rods, so the components of the grounding system appear as a single point of uniform impedance.



WARNING!

Low impedance grounding is **mandatory for personnel safety** and critical for the proper operation of the cable system.

1.0 Introduction to the VMX Power Supply

The Alpha family of VMX Uninterruptible Power Supplies is designed for powering signal processing equipment in cable television and broadband LAN distribution systems. The VMX provides a critical load with current-limited, regulated, AC power that is free of spikes, surges, sags and noise.

During AC line operation, AC power entering the power supply is converted into a *quasi* square wave and is regulated by a ferroresonant transformer at the required output voltage. The regulated voltage is connected to the load via the OUTPUT 1-4 ± terminal block connections, and some power is directed to the battery charger to maintain a float charge on the batteries.

When the incoming AC line voltage significantly deviates from normal, the VMX Power Supply automatically switches from the AC line to Standby mode, maintaining power to the load. During the switch to standby operation, energy in the module's ferroresonant transformer continues to supply power to the load. While in Standby mode, the VMX powers the load until the battery voltage reaches a low-battery cutoff point.

When utility power returns, the VMX Power Supply waits a short time (approximately 10 to 20 seconds) for the utility voltage and frequency to stabilize, and then initiates a smooth, in-phase transfer back to AC line power. Once the transfer is complete, the battery charger recharges the batteries in preparation for the next event.

Key components of the VMX Power Supply include a line-conditioning ferroresonant transformer, resonant capacitor, transfer isolation relay, and inverter. The inverter contains circuitry for the three-stage temperature-compensated battery charger, DC to AC converter (inverter), AC line detector, and Smart Display. An optional communication module provides remote status monitoring.

The VMX Power Supply features:

- Line Interactive Ferro Technology (LIFT)
- Smart Display
- Built-in programmable battery self-test
- 3-stage temperature compensated battery charger
- Automatic battery detection
- Field programmable flash memory
- Four-Output Protection Interface Module
- Digital status monitoring (optional)



Fig. 1-1, VMX Power Supply

1.0 Introduction to the VMX Power Supply, continued

1.1 Connections Overview

Below is a brief description of each terminal.

Connections:

- **AUX OUT** (Auxiliary Output): The Auxiliary Output is an uninterruptible supply of power that can be used to power external devices such as cable modems or ethernet hubs. The auxiliary output is rated at 220V 150W and uses a 2A 250V fast blow fuse (Alpha P/N 460-157-19).
- **LRI** (Local/Remote Indicator): The LRI lamp option connects to the LRI ± terminals on the terminal block. The LRI circuit is rated at 12Vdc, 250mA. This option duplicates the function of the red ALARM LED by illuminating an externally mounted red lamp.
- **Voltage Out:** The Protective Interface Module (PIM) allows the VMX Uninterruptible Power Supply to provide programmable current limits for four output channels. The Service Power Inserter (SPI) connects into the Voltage Out terminals.
- **Ground:** A ground wire (up to 6 AWG) can be connected to the ground lug to permanently tie the chassis to utility ground. This may be desired when an AC generator is connected to the power supply, because the chassis ground through the line cord is removed when the line cord is plugged into the generator.
- **V SEL** (Voltage Select): The voltage select jumper can be configured for either the 63V output or the 48V output. The voltage values may vary between models.

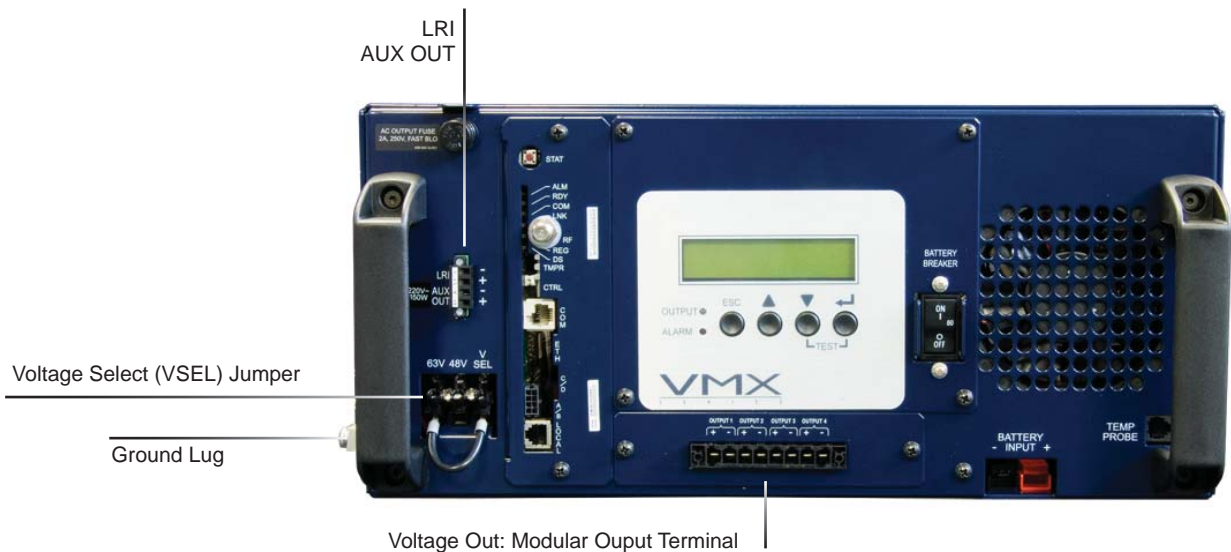

Fig. 1-2, VMX Terminal Block Overview



NOTE:

If using the Alpha SPI with the VMX power supply, cut the Anderson connector off of the SPI and strip the wires 3/8" and connect them to the output terminal.

1.0 Introduction to the VMX Power Supply, continued

1.2 Inverter Overview

The inverter provides uninterrupted power to the ferroresonant transformer (via the batteries) during line failures. During line operation, the inverter charges the batteries using a three-stage (Bulk, Accept, and Float) charger.

Components:

- **Smart Display:** All operational functions, system testing, setup items, and alarms are available via the Smart Display panel on the front of the VMX Power Supply (the Smart Display is covered in detail in Section 5.2). Display functions are accessible by pressing any of the four keys: ESCAPE, UP, DOWN, and ENTER. Backlighting is activated when any of the four keys are pressed, and stays illuminated for one hour. There are four levels of menu items: Operation Normal, Additional Information, Setup, and Alarms. Press ENTER to display one level lower. Press ESCAPE to display one level higher. Press ESCAPE to toggle between the main menu and alarm menu when alarms are present.
- **Battery Breaker:** The battery breaker disconnects the batteries from the inverter's DC circuit. With the battery breaker turned off, the VMX Power Supply will not transfer to standby mode, the inverter is disabled, and the battery charger cannot charge the batteries. If an overcurrent is detected in the DC circuitry the breaker will trip.
- **Battery Input Connector (Red = Positive; Black = Negative):** The batteries plug directly into the inverter's battery connector. The connector is color-coded and fits in one direction only.
- **Inverter Cooling Fan:** The inverter is equipped with a cooling fan that operates during standby operation, or when the inverter heatsink temperature reaches 85°C. The fan stays on until the temperature drops below 75°C. The fan also operates any time a self-test is in progress.
- **Battery Temp Probe Connector:** The Remote Temperature Sensor (RTS) plugs directly into the temperature probe (RJ-11C type) connector. The sensor end of the RTS is routed to the battery compartment and taped directly to the side of the center battery. The RTS provides battery temperature measurements used to adjust the battery charge voltage.

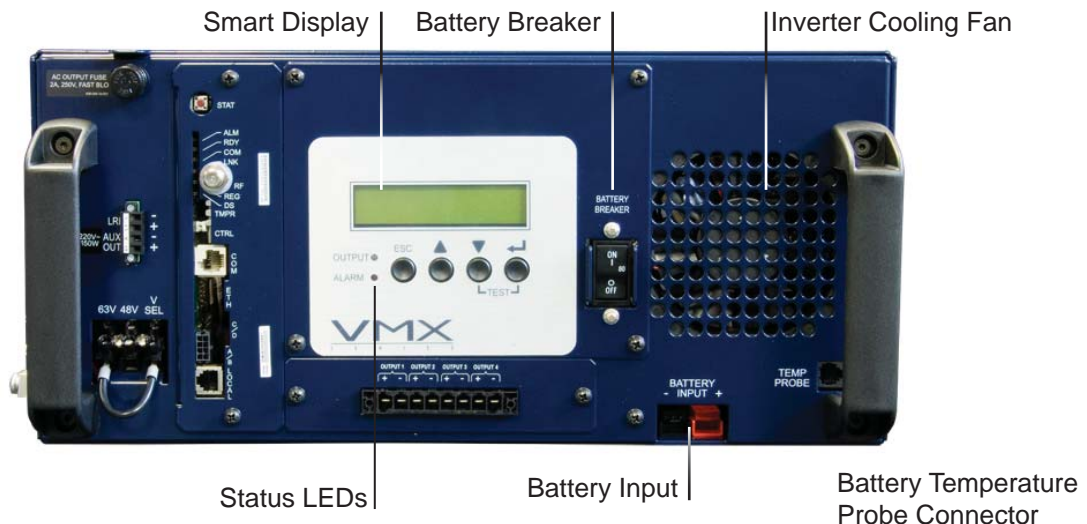

Fig. 1-3, Inverter Overview

1.0 Introduction to the VMX Power Supply, continued

1.3 Optional Status Monitoring Modules

The VMX Power Supply supports a number of Alpha Technologies communications modules. The modules may be ordered factory-installed or as user-installed field upgrades.



CAUTION!

Handle these modules with extreme care. Circuit boards and logic upgrades are static-sensitive and susceptible to damage.

AlphaNet™ Ethernet Status Monitor (ESM)

The AlphaNet ESM (Alpha P/N 745-814-40) allows monitoring of your VMX Power Supply via a network connection. Advanced features and networking services provide for quick reporting and access to critical powering information, keeping your broadband network running reliably.

The AlphaNet ESM supports the standard networking protocols required for effective power network management. The ESM provides efficient network status monitoring and diagnostics using Simple Network Management Protocol (SNMP) and standard MIBs. A Web interface enables authorized personnel direct access to powerful, advanced diagnostics using a common Web browser. No custom software is required. *Refer to the AlphaNet ESM Technical Manual, Alpha P/N 704-782-B0, for more information.*



AlphaNet ESM

AlphaNet™ DOCSIS Status Monitor (DSM) and Euro DSM

The AlphaNet DSM (Alpha P/N 745-825-30) and EuroDSM (745-814-43) provide the same functionality as the AlphaNet ESM, but feature an environmentally hardened embedded DOCSIS® cable modem for convenience and reliability. *Refer to the AlphaNet XP-DSM Technical Manual, Alpha P/N 745-814-B0, for more information.*



AlphaNet EuroDSM



NOTE:

A hardware kit (Alpha P/N 745-818-22) is available for the ESM, DSM, or EuroDSM, communications modules. This kit contains sheetmetal and interconnect cabling, and should be ordered along with the modules.

AlphaGuard™ Battery Charge Management System

The AlphaGuard Battery Charge Management System extends battery life by providing the precise voltage required for each battery. You can replace single batteries as they fail, not the entire string. It spreads charge voltage equally across batteries, and batteries no longer need to be matched. It adjusts for battery changes as they age. The optional communications module monitors individual battery voltage during inverter operation, protecting against damage from over discharge. The AG-CMT-3 model supports 36V battery strings. The AG-CMT-4 supports 48V battery strings. *Refer to the AlphaGuard Installation Instructions, Alpha P/N 012-306-C0, for detailed information.*



AlphaGuard CMT

1.0 Introduction to the VMX Power Supply, continued

1.4 Optional Features

The following options can be factory installed, or upgraded in the field by the user:

Local and Remote Indicator (LRI)

The LRI (red) lamp is located on the outside of pole-mount enclosures. During normal AC line operation, the LRI remains off. The LRI comes on only when the power supply is running in Standby Mode. Whenever a fault is detected during self-test, the LRI flashes to indicate that service is required. The LRI is a simple form of status monitoring that allows operators to check the operational status of the power supply without having to climb the pole and open the enclosure (Alpha P/N: 740-139-20).

AC Indicator (ACI)

The AC Indicator (green lamp) is located next to the LRI on the outside of pole-mount enclosures. As long as there is voltage present at the output, the ACI remains on. As with the LRI, it acts as a simple form of status monitoring that allows cable technicians to check the output status of the power supply without having to climb the pole and open the enclosure. Alpha recommends using the ACI-LL (long life LED) because it provides much longer life than the original light bulb design. Models for 60V and 90V are available. ACIs are *not* recommended for ground mount enclosures (Alpha P/N: 740-167-21).

LA-P+ 240V (Lightning Arrestor)

The LA-P+ plugs directly into the enclosure's convenience outlet, to provide additional protection from voltage spikes caused by lightning and other power disturbances. It eliminates the need for hard-wired MOVs. No additional wiring is necessary (Alpha P/N: LA-P+240)

ATTENTION:

Utility safety ground must meet all local and national standards and regulations.

2.0 Theory of Operation

2.1 AC (Line) Operation

During AC line operation, utility power is routed into the primary winding of the ferroresonant transformer through the contacts of the transfer isolation relay. At the same time, power is directed to the rectifier circuitry in the inverter which provides power for the control circuitry. The bidirectional inverter also serves as a battery charger during AC line operation. The ferroresonant transformer and an AC capacitor form the resonant tank circuit, which provides excellent noise and spike attenuation, output short circuit current limiting, and output voltage regulation. The ferroresonant transformer produces a *quasi* square wave output which resembles a rounded square wave.



CAUTION!

To minimize the possibility of the transformer entering unstable operation, the VMX Power Supply requires a minimum load of at least one ampere connected to the output. Unstable transformers will self-correct as soon as a load of one ampere or greater is connected to the power supply.

2.2 Standby Operation

When incoming AC line voltage drops or rises significantly, or a complete power outage occurs, the VMX line monitor activates standby operation. During the transfer from AC line to standby operation, the battery powered inverter comes on-line as the isolation relay opens to prevent AC power from back-feeding to the utility. The energy contained in the ferroresonant transformer continues to supply power to the load. The following changes also occur within the VMX Power Supply:

- The control logic drives the inverter field-effect transistors (FETs) on and off. This switching action converts the DC battery current into AC current in the inverter winding of the ferroresonant transformer, which provides regulated power to the load.
- The control logic, which includes a microprocessor and other circuits to protect the inverter FETs from overcurrent damage, monitors the condition of the batteries and the inverter during standby operation. Since a prolonged AC line outage would severely discharge the batteries, resulting in permanent damage, the control logic disables the inverter when the batteries drop to approximately 10.5Vdc per battery.

When acceptable AC line voltage returns, the power supply transfers back to AC line operation within 10 to 20 seconds. This delay allows the AC line voltage and frequency to stabilize before the control logic phase-locks the inverter's output to the utility input. The control logic then de-energizes the isolation relay, reconnects the AC line to the primary of the ferroresonant transformer and disables (turns off) the inverter. This results in a smooth, in-phase transfer back to utility power without interruption of service to the load. The battery charging circuit then activates to recharge the batteries in preparation for the next power outage. In the case of a prolonged AC outage where the inverter shuts off due to low battery voltage, the output will return as soon as the AC line voltage returns.



NOTE:

The duration of battery-backed standby operation depends upon the type and number of batteries and the load on the power supply.

2.0 Theory of Operation, continued

2.3 Charger Operation

The VMX Power Supply uses a three-stage, temperature-compensated battery charger. During AC line operation, the inverter winding on the ferroresonant transformer feeds the charger circuit which provides BULK, ACCEPT, and FLOAT charge voltages to the batteries.

Charger Modes:

TEST: When the power supply first starts, transfers back to line, or when batteries are first connected, the power supply will indicate the charger mode is TEST for a period of up to 10 minutes. The charger will operate the same as BULK mode, but with a slightly different battery detection method. The charger mode will also indicate TEST during self-test.

BULK charge is a “Constant Current” charge. The maximum charger current is 10 Amps. As the charge is returned to the batteries, their voltage increases to a specific threshold (2.27Vdc per cell). This cycle ends when the charging current into the batteries becomes less than 0.5A. The charger then switches to ACCEPT mode. The BULK charger mode generally returns the battery charge state to 80 percent of rated battery capacity.

ACCEPT charge is a “Constant Voltage” charge. This voltage, 2.40Vdc (adjustable) per cell, is temperature-compensated to ensure longer battery life and proper completion of the charge cycle. This cycle is complete when the charging current into the batteries becomes less than 0.5A, or approximately six hours from the time ACCEPT mode was entered. When the batteries are fully recharged the charger switches to the FLOAT mode of operation.

FLOAT charge is a temperature-compensated “pulsed voltage” charge, averaging about 2.27Vdc (adjustable) per cell. During FLOAT mode, the batteries are fully charged and ready to provide backup power. The charger provides a small maintenance charge to overcome the batteries self-discharge characteristics and other minor DC loads within the power supply. As the battery voltage reaches the “full charge” level the time delay between pulses increases.

The cell voltage is temperature-compensated at -0.005Vdc per cell per degree Celsius (adjustable) to ensure a safe battery cell voltage and maximize battery life. The temperature compensation is limited to an absolute battery voltage minimum of 2.20V per cell and a maximum of 2.50V per cell regardless of the temperature compensation settings.

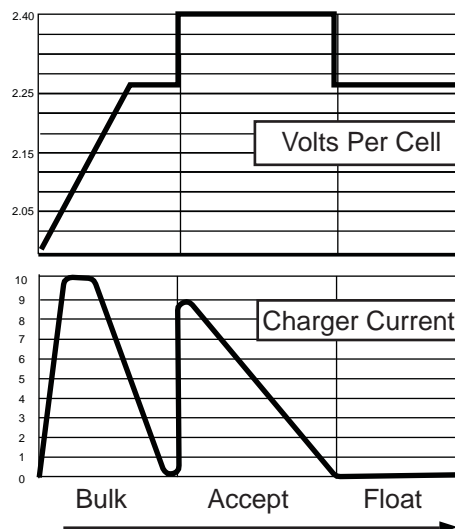

Fig. 2-1, Charger Modes

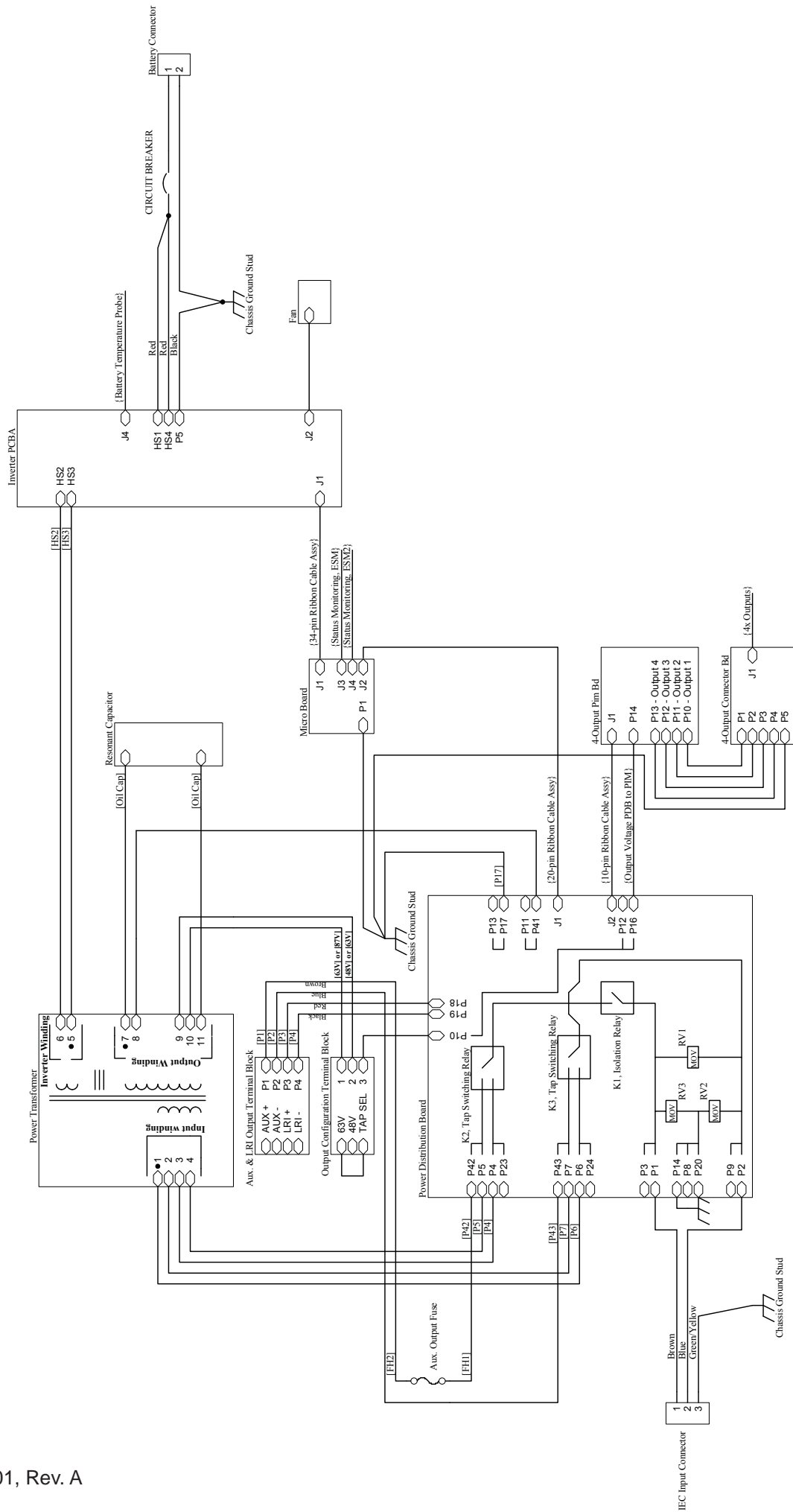

Fig. 2-2, VMX Block Diagram

3.0 Installation



CAUTION!

Refer to the Safety Precautions, Utility Power Connection Notes, and Grounding Connection Notes (pages 7-12) prior to installation.

To Ensure Operator Safety:

- Only qualified personnel should install the power supply in accordance with all applicable electrical codes.
- Use eye protection whenever working with batteries.
- Use only sealed, lead-acid type batteries with a minimum rating of 55Ah (gelled-electrolyte or equivalent).

Unpacking and Inspection:

Remove the VMX Power Supply from the shipping container. Verify that the power supply (including Remote Temperature Sensor) and any other ordered options have been included.

Carefully inspect the contents of the shipping container. If any items are damaged or missing, contact Alpha Technologies or the shipping company immediately. Most shipping companies have only a short claim period.

Preinstallation Inspection:

- During shipping, movement of components may occur. Inspect the power supply for possible shipping-related failures, such as loosened or damaged connectors. If needed, inspect the interior for loose or damaged connectors. Correct any discrepancies before proceeding with the power supply installation.
- Do not attempt to install a damaged power supply without first passing a complete Preinstallation Inspection and Start-up Test.



NOTE:

Please refer to the “VMX Standby Power Supply — Quick Start Guide” (Alpha P/N 017-940-B1) that accompanies each power supply. **SAVE THE ORIGINAL SHIPPING CONTAINER.**



CAUTION!

Use the original shipping container if the VMX Power Supply needs to be returned for service. If the original container is not available, make sure the unit is packed with at least three inches of shock-absorbing material in all orientations to prevent shipping damage. Do not use popcorn-type material. Alpha Technologies is not responsible for damage caused by improper packaging on returned units.

3.0 Installation, continued

3.1 Installation Procedure

The VMX Power Supply has been designed for shelf mounting in the horizontal configuration or wall-mounting in the vertical configuration.

1. Before installing the power supply, inspect for damage, loose connectors, or other potential failures. Correct discrepancies before proceeding.
2. For horizontal configurations, place the VMX Power Supply on the appropriate enclosure mounting shelf. The unit is placed in the lower-right compartment of PME enclosures, the upper compartment of PWE, UPE, UPE/M Enclosures, and on the equipment trays of PN Series enclosures.

For vertical configurations, mount the VMX Power Supply securely to a wall allowing for plenty of space for connections and servicing (vertical dimensions in/mm: H 11.7/297 x W 20/508 x D 9/229).



NOTE:

Alpha enclosures are designed to properly vent the VMX Power Supply. If using a non-Alpha enclosure, it is the customer's responsibility to ensure the VMX Power Supply remains within its environmental specifications.



CAUTION!

Batteries are an important part of the VMX Power Supply. Properly install and test all batteries, battery connections, and battery cables before connecting to the power supply.

3. Make sure the battery breaker is off. After the batteries, battery connections, and battery cables have been tested, plug the quick connects from the battery cable into the Battery Input connection. The connector is keyed and color-coded to fit in only one direction.
4. Plug the Remote Temperature Sensor into the Temp Probe connection. Route the sensor end of the cable into the battery compartment, and attach it to the side of the center battery.
5. If the optional LRI (Local and Remote Indicator) is included, connect the LRI terminal block connections. Make connections to the auxiliary output if applicable.
6. If ESM or DSM status monitoring is used, plug the tamper switch connector into the 2-pin TMPR connector on the front of the ESM.
- 6a. Connect the auxiliary output terminal block connections, if needed.
7. If using a Service Power Inserter, proceed to Section 3.2. If you are not using an SPI, connect the load to the Output 1-4 ± terminals on the terminal block and tighten clamping screws.

3.0 Installation, continued

3.2 Service Power Inserter Connections

SPI Connection Procedure:

1. Ensure the SPI is unplugged from the power supply prior to removing cover.
2. Remove the two screws holding the cover to the SPI's chassis.
3. Remove the SPI cover, exposing the circuit board and seizure screw assembly.

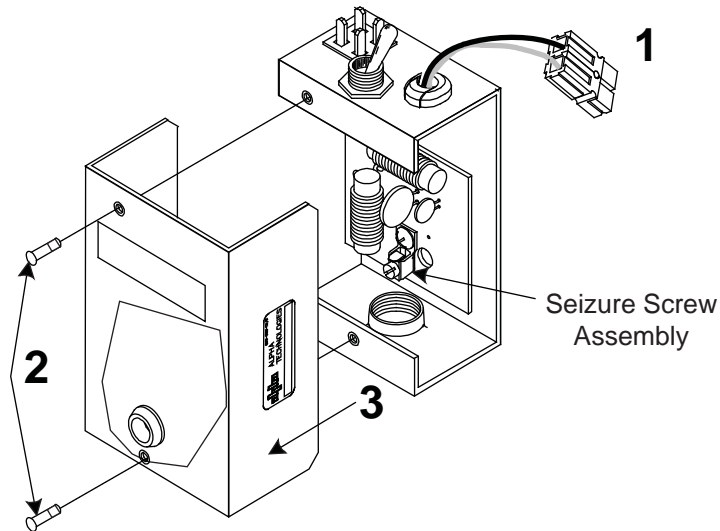

Fig. 3-1, SPI Cover Removal

4. Insert the coaxial termination into the output port on the bottom of the SPI and tighten the nut snug.
5. Tighten the seizure screw to 4 Nm (35 in-lbs).

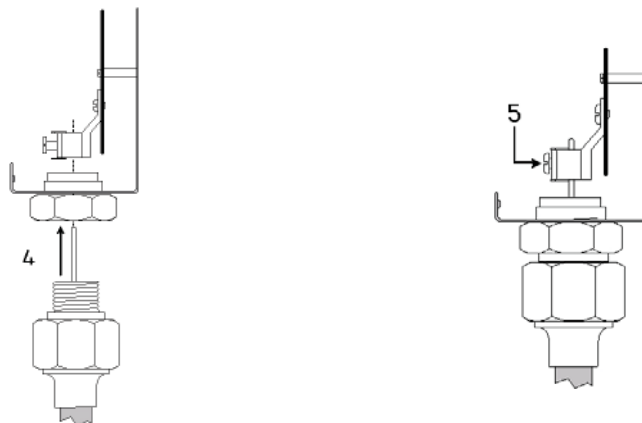

Fig. 3-2, Coaxial Cable Insertion and Securing

CAUTION!
To prevent arcing, insert the center conductor (stinger) of the coaxial termination completely inside the seizure screw assembly (5). Tighten to 4 Nm (35 in-lbs).

3.0 Installation, continued

3.2 Service Power Inserter Connections, continued

6. Replace the SPI cover and reinstall the screws.
7. Verify the switch on the top of the SPI is in the ON position. The switch in the ON position selects the VMX Power Supply as the power source to the cable plant. The switch should only be in the ALT position when a service power supply is connected to the cable. At this time, the standby power supply is bypassed for service or removal.
8. Verify the SPI is properly grounded. Typically, grounding is accomplished by one of two methods:
 - a. If the SPI has been installed with a mounting bracket, ground connection is made with paint-cutting star washers (Fig. 3-3) used in conjunction with SPI grounding wire.
 - b. If the SPI doesn't utilize the mounting bracket, the ground connection is made via a #8AWG wire connected to the cover of the SPI (Fig. 3-4) and terminated at the ground bar of the cabinet (Fig. 3-5).

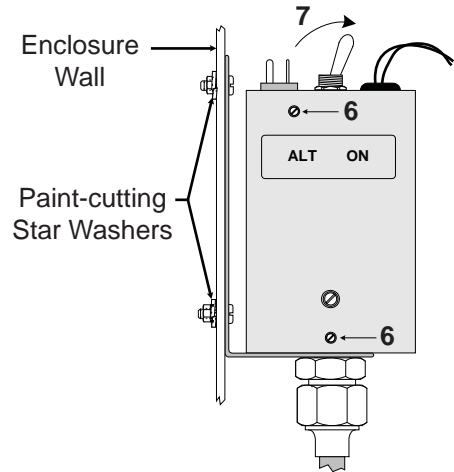

Fig. 3-3, Cover Replaced, SPI Switched On

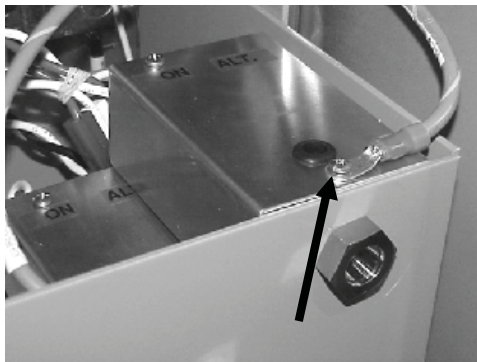

Fig. 3-4, SPI Grounding Lug



Fig. 3-5, Enclosure Ground Bar

9. Remove the black and white wires from the Anderson connector (see Fig. 3-6) and strip the wire ends 8mm (3/8").

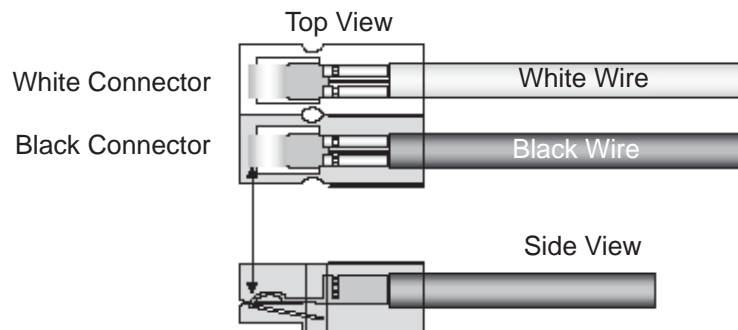

Fig. 3-6, Wire/Connector Assembly

3.0 Installation, continued

3.2 Service Power Inserter Connections, continued

10. Insert the Black wire into the Output 1-4 + (positive) terminal and tighten the clamping screw.
11. Insert the White wire into the Output 1-4 - terminal (negative) terminal and tighten the clamping screw.

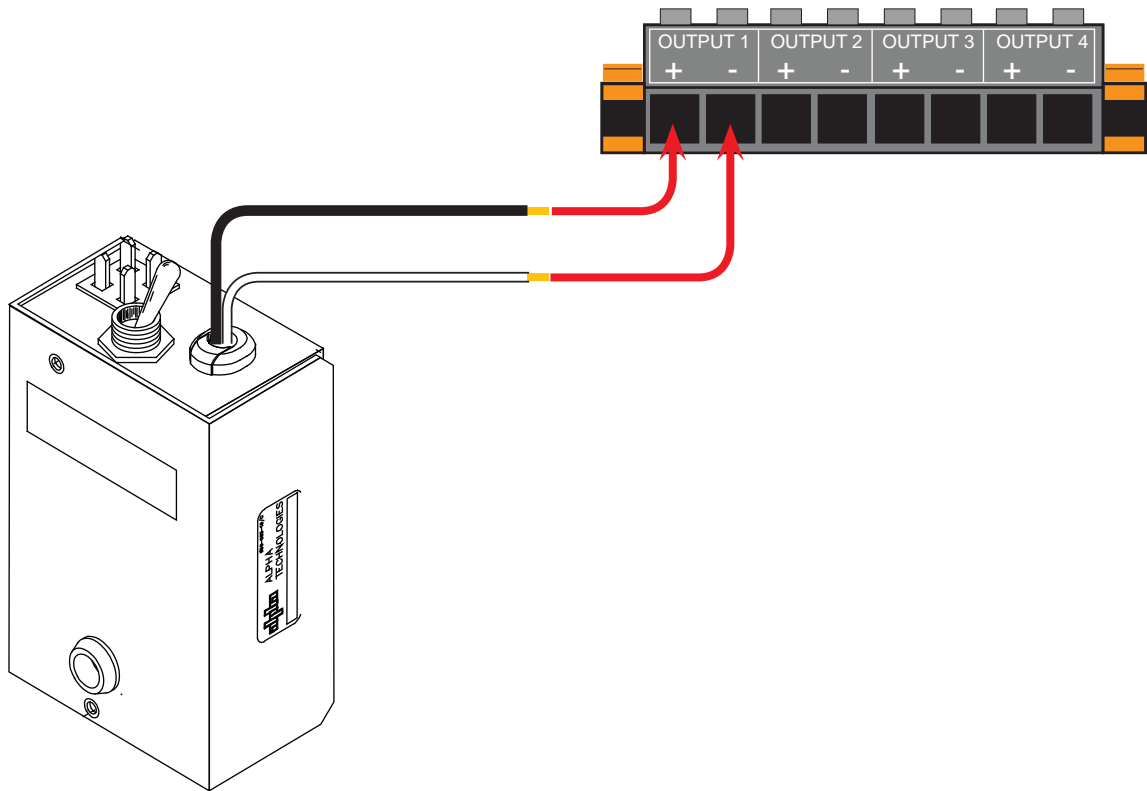

Fig 3-7, SPI to Output 1-4 Connection

3.0 Installation, continued

3.3 Installing the Coax Cable Connector Outputs



WARNING!

Before performing the following procedure, disconnect the power supply from line voltage and switch the battery breaker OFF.

The VMX Standby Power Supply can be adapted to support four coax cable outputs.

Necessary Tools:

Philips Screwdriver

Procedure:

1. Remove the two small bolts securing the four-output connector plate.



2. Pull the connector plate clear of the chassis and disconnect the five wires.

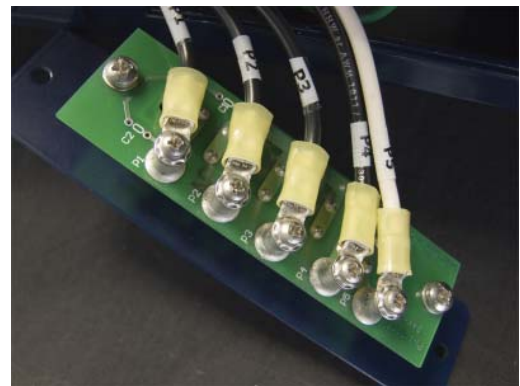

3. Connect the wires to their appropriate terminals on the coax cable connector. The neutral wire mounts below the board.

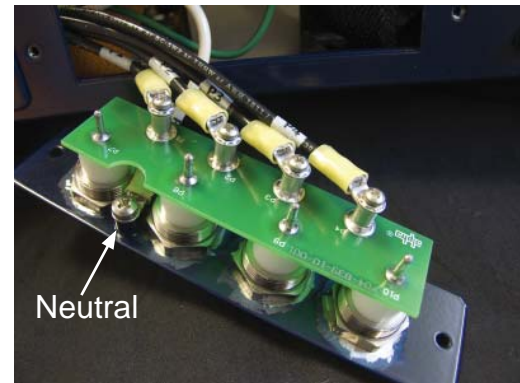

4. Secure the coax cable connector plate to the power supply using the two small bolts. Reconnect line power and switch the battery breaker ON.



4.0 Configuration

4.1 Micro Board Setup

The Micro Board comes factory set, but the Micro Board switches are accessible should a configuration change be necessary. Setup details are included in this manual as an aid to troubleshooting, and as a reference to verify configuration. Only qualified technicians should perform reconfiguration. To access the Micro Board, remove the eight front panel Phillips screws indicated.

Input Voltage (SW1-1): Factory set to order. Never change this setting.

Frequency (SW1-2): Factory set to match the ferroresonant transformer operating frequency of either 60Hz or 50Hz. This setting should never be changed.

Output Current Rating (SW1-3 and SW1-4): Factory set. Output Current Rating is set to match the model of the power supply. Never change this setting.

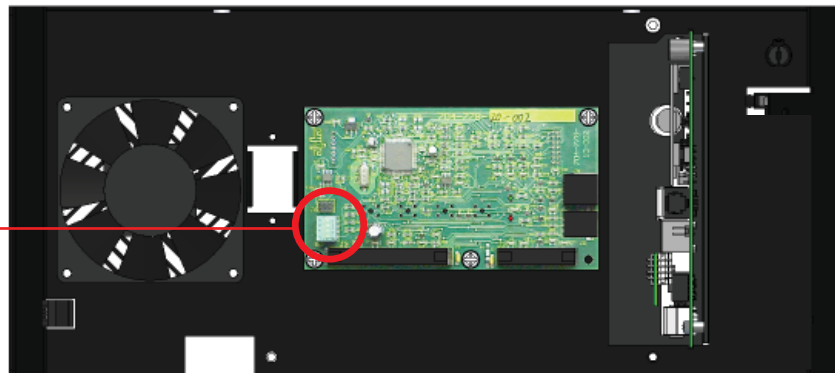

Back of front panel

	OFF	ON					
V_{in}, SW1-1	225V	115V	I_{out}	15A	22A	NA	NA
Freq, SW1-2	60Hz	50Hz	SW1-3	OFF	ON	OFF	ON
			SW1-4	OFF	ON	ON	OFF

Factory set. Do not change settings.

Fig. 4-1, Micro Board DIP Switch Settings

4.0 Configuration, continued

4.2 AC Output Voltage Reconfiguration

Tools Required: Small flat-blade torque screwdriver

The output voltage on VMX Power Supplies can be easily reconfigured by moving the Output Tap jumper to 63 or 48Vac, or 63 or 87Vac, depending on the VMX model.

ATTENTION:

Output voltage reconfiguration must only be performed by qualified personnel.



WARNING!

Before proceeding, make certain *all* power has been removed from the power supply by unplugging the power supply from the AC power source, front panel connections, and disconnecting the battery connector. Failure to do so could expose the technician to potentially lethal voltages.

Output Voltage Reconfiguration Procedure:

1. Unplug the Line cord. Turn off the battery breaker and unplug the battery connector on the front of the unit.
2. Loosen the Tap Select wire screw on the terminal block. Move the Tap Select wire to the 87V, 63V, or 48V output voltage position, as desired.



CAUTION!

Do not jumper the 87V terminal, 63V terminal, or 48V terminal together.

3. Re-tighten the Tap Select wire screw and torque to 0.8 Nm (7.0 in-lbs).
4. Reconnect the front panel connections. Turn on the battery breaker, and plug in the line cord. Verify operation of the power supply.

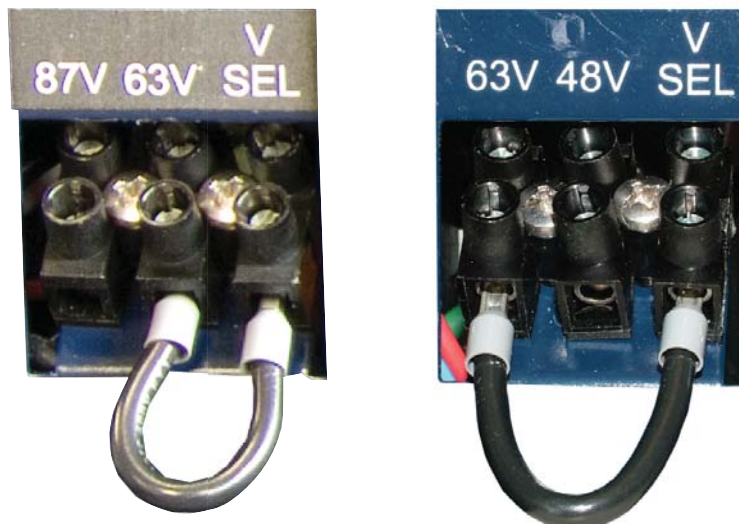

Fig. 4-2, Transformer Output Tap Connectors

5.0 Operation

5.1 Start-up and Test

AC Line Operation

1. Before making any power supply connections, verify the correct voltage, polarity, and frequency are available from both the AC utility power source and the DC battery system.
2. Verify the AC circuit breaker (located on customer supplied service disconnect) and the battery breaker on the VMX Power Supply are off.
3. Plug the VMX Power Supply power cord into the enclosure convenience outlet, and the battery cable into the Battery Input connector on the front of the power supply. Plug the RTS into the Temp Probe connection and attach it to the side of the center battery. If applicable, connect the LRI wiring to the LRI \pm terminals and the auxiliary output wires to the AUX \pm terminals on the terminal block.
4. Switch the AC (service disconnect) circuit breaker on to start initial power up. During this stage the power supply performs a “display self-test”, and verifies the configuration for the power supply. The configuration screen looks similar to the figure below. After the initial display self-test, a No Batteries alarm message appears in the Smart Display because the battery breaker is still off. The green output LED remains off, and the red alarm LED continues to flash until the battery breaker is switched ON and the power supply qualifies the batteries (this may take up to one minute).



Fig. 5-1, Configuration Screen

5. Switch on the battery breaker. Within one minute the flashing red alarm LED turns OFF, the green output LED turns ON, the No Battery alarm clears, and the power supply resumes normal operation. Use the Smart Display to verify operations and Setup as needed.

5.0 Operation, continued

5.1 Start-up and Test, continued

AC Line Operation, continued

6. Use the Smart Display or a true RMS voltmeter to verify AC output ($\pm 5\%$) at the module's AC Output test point. If a non-RMS voltmeter is used, the output reading can vary by as much as 10% due to the "quasi" square wave output of the ferroresonant transformer.

SETTING	LOW (-5%)	HIGH (+5%)
87Vac	82.65Vac	91.35Vac
63Vac	59.85Vac	66.15Vac
48Vac	45.60Vac	51.40Vac

**NOTE:**

The Configuration Screen can be accessed any time by simultaneously pressing UP and ENTER (↑ ←).

7. Use the Smart Display to verify VMX Power Supply operations. Press ENTER (←) to view Normal Information. Press ENTER (←) again to view Additional Information. Press ENTER (←) a third time to view the Setup Menu. If desired, the No Battery alarm can be disabled by changing Battery Capacity to "0".

**NOTE:**

Disabling the No Battery alarm is only recommended for applications not using batteries.

Self-test Operation

1. The VMX Power Supply should be operating correctly with no alarms present. Use the Smart Display to verify Normal and Additional Information. Verify test duration in the Setup Menu as needed.
2. Press and hold DOWN and ENTER simultaneously to start Self-test. The test runs for a preset time (5 to 180 minutes, set in the Setup Menu). Self-test can also be entered by setting Self-test to ON in the Setup Menu.
3. While in Self-test mode, use the Smart Display or a true RMS voltmeter to verify output at the terminal block OUTPUT 1-4 terminals. Output voltages should appear within $\pm 5\%$ of 87Vac (for 90V units), 63Vac (for 60V units), and 48Vac (for 48V units) at nominal line input voltage.

SETTING	LOW (-5%)	HIGH (+5%)
87Vac	82.65Vac	91.35Vac
63Vac	59.85Vac	66.15Vac
48Vac	45.60Vac	50.40Vac

4. To cancel a Self-test in progress, push and hold DOWN and ENTER a second time, or change Self-test to OFF in the Setup Menu.

5.0 Operation, continued

5.1 Start-up and Test, continued

Standby Operation

1. Perform the following procedure after successful completion of a self-test with the VMX Power Supply operating normally in AC line mode: Momentarily fail the AC utility input power by switching the AC circuit breaker (service disconnect) to OFF.
2. The VMX Power Supply should start operating in the inverter mode. Use the Smart Display or a true RMS voltmeter to verify output at the OUTPUT 1-4 \pm terminals. Output voltages should appear within $\pm 5\%$ of 87Vac (for 90V units), 63Vac (for 60V units), or 48Vac (for 48V units) at nominal line input voltage.

SETTING	LOW (-5%)	HIGH (+5%)
87Vac	82.65Vac	91.35Vac
63Vac	59.85Vac	66.15Vac
48Vac	45.60Vac	50.40Vac

3. Return the VMX Power Supply to AC Line mode by switching the AC (service disconnect) circuit breaker to ON. The transfer back to utility power may take 10 to 20 seconds. This delay allows the utility voltage and frequency to stabilize before the module's phase-lock circuitry is activated. The module then synchronizes the inverter's waveform to the utility's before initiating a smooth, in-phase transfer back to utility power. Once the transfer is complete, the smart display will report: OPER MODE = LINE.
4. The VMX Power Supply is now fully operational.

5.0 Operation, continued

5.2 Smart Display

All operational functions, system testing, setup menus, and alarms are available via the illuminated display panel on the front of the VMX Power Supply. Display functions are accessible by pressing any of the four keys: ESCAPE, UP, DOWN, and ENTER. Descriptions of key functions are as follows:

ESCAPE:

ESCAPE offers the following features:

Move up one level in the menu tree.

Allow the operator to leave the EDIT mode without saving the changes made to the selected menu item.

UP: ▲

UP serves two primary functions:

- To scroll up in a branch of the menu tree.
- To increase a parameter (or value) while in the EDIT mode.

DOWN: ▼

DOWN serves two primary functions:

- To scroll down in a branch of the menu tree.
- To decrease a parameter (or value) while in the EDIT mode.

ENTER: ↵

ENTER provides the following functions:

- Displays the next lower level in the menu tree.
- In the EDIT mode, ENTER accepts the new value into memory.
- Depressing ENTER for two seconds or longer initiates Display Test mode. Display Test mode switches all LED and LCD pixels (dots) on for several seconds. The display then shows the Engineering Diagnostics screen. Press ESC to return to the Main Menu.

Self-test: ▼ and ↵

The VMX Power Supply can manually be placed in a self-test mode by pressing DOWN and ENTER together:

- Press and hold DOWN and ENTER simultaneously for about three seconds. A self-test initiates and runs between 5 to 180 minutes (set in the setup menu).
- To cancel a self-test in progress, simultaneously press and hold DOWN and ENTER for about three seconds.



Fig. 5-2, Smart Display

5.0 Operation, continued

5.2 Smart Display, continued

Display Backlighting

The display will normally be unlit. Press any key once to activate backlighting. This will illuminate the display without deactivating Auto Scroll.

Auto Scroll



The display will normally be in the Auto Scroll mode, continually cycling through the sub-menu items at a two-second interval. In Auto Scroll mode the operator can quickly view menu items without the need to press any keys.

Single Step

Pressing either arrow key will activate Single Step mode, allowing the operator to step through the individual menu items. Each press of the arrow key will step up or down through the sub-menu items. Press ESC to return to the Auto Scroll mode.

Direction Indicator Symbols

The rightmost character of the display (may appear on either line) indicates the proper key function when manually scrolling. Where more than one choice is available multiple characters will appear. The following characters or text may appear:

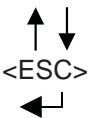
-  Access more menu items by pressing either the UP or DOWN arrow keys.
-  Use the ENTER key to select this function.
- <ESC> Use the ESCAPE key to leave the selected function without altering any values or to go back to the previous menu in the display.
-  Press UP or DOWN arrows to change a display value or mode. Press ESCAPE to leave this menu item without making any changes (and go back to the previous menu). Press ENTER to save the change into memory. This type of multiple display choice is normally available in the programming mode.

5.0 Operation, continued

5.2 Smart Display, continued

5.2.1 Operation Normal

If no alarms are present, the VMX Power Supply operates in the Operation Normal mode. This mode allows the operator to view the primary operating parameters of the power supply. In this mode, the display will auto scroll through the available menu items at two-second intervals. In the Normal Operation mode, the displayed items are all “metered” items, and are for informational purposes only (not programmable) with respect to the operational status of the power supply.

The Normal Operation menu contains the following items:

Top Line (provides additional instructions):

- OPERATION NORMAL
- ↑↓ TO MANUAL SCROLL
- ← FOR ADDIT'L INFO

Second Line (cycles through the following parameters):

- INPUT VOLTAGE *xxxV*
- BATT VOLTS *xx.xV*
- OUTPUT VOLTAGE *xxV*
- OUTPUT 1 CURRENT *xx.xA*
- OUTPUT 2 CURRENT *xx.xA*
- OUTPUT 3 CURRENT *xx.xA*
- OUTPUT 4 CURRENT *xx.xA*
- INPUT WATTS *xxxxW*
- *xx* EVENTS *xxx* MIN
- CHARGER MODE = *float*
- OPER MODE = *line*



NOTE:

Lower case *italicized* items indicate variables that change according to the operating mode, setup, or measured values. These items will appear as normal UPPER CASE text in the actual display.

5.0 Operation, continued

5.2 Smart Display, continued

5.2.2 Additional Information Display

Press ENTER to activate the Additional Information display, which is an extension of the Normal Operation mode and displays information of secondary importance to the operator. When the Additional Information display is first accessed, information is displayed in the Auto Scroll mode. Pressing UP or DOWN allows the information to be accessed one step at a time. Pressing ENTER will access the Setup Menu (discussed in Section 5.2.3, Setup Menu). Pressing ESCAPE reactivates Auto Scroll mode. Pressing ESCAPE a second time reactivates the Normal Operation display (up one level).

The Additional Information display contains the following items:

Top Line (Provides additional instructions):

- ADDITIONAL INFO
- ↓↑ TO MANUAL SCROLL
- ← TO SETUP MENU
- <ESC> TO SYSTEM INFO

Second Line (cycles through the following parameters):

- BATTERY TEMP *xx*°C
- CHARGER CURR *xx.x*A
- INPUT FREQ *xx.x* HZ
- OUTPUT WATTS *xxx* W
- OUTPUT VA *xxx*
- PERCENT LOAD *xx*%
- INPUT CURRENT *xx.x*A

 **NOTE:**

Lower case *italicized* items indicate variables that change according to the operating mode, setup, or measured values. These items appear as normal UPPER CASE text in the actual display. INPUT FREQ is not valid during inverter operation.

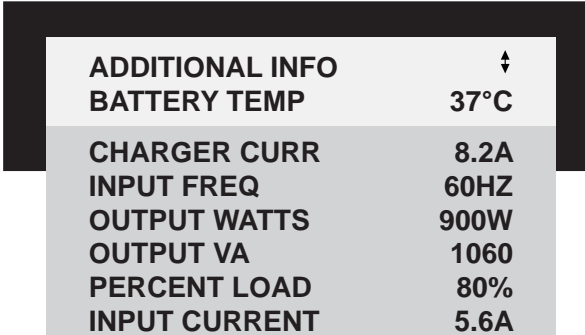

ADDITIONAL INFO	↓↑
BATTERY TEMP	37°C
CHARGER CURR	8.2A
INPUT FREQ	60HZ
OUTPUT WATTS	900W
OUTPUT VA	1060
PERCENT LOAD	80%
INPUT CURRENT	5.6A

Fig. 5-3, Additional Info Display
(Examples are given for values in the display)

5.0 Operation, continued

5.2 Smart Display, continued

5.2.3 Setup Menu

The Setup Menu is one level below the Additional Information display and is reached by pressing ENTER. Use this menu to view and change the programmable operating parameters of the power supply. Navigation is similar to the Normal Operation menu. Pressing UP or DOWN accesses the Single Step mode, where sub-menu items can be individually selected.

To select and change a value in the Setup Menu:

1. Press either UP or DOWN to put the display in the Manual Scroll mode.
2. Continue pressing UP or DOWN until the desired item displays.
3. Press ENTER to select the item for editing.
4. Use UP to increase the displayed value, or DOWN to decrease the value. Pressing and holding either UP or DOWN for more than two seconds while in edit mode causes the displayed value to change more rapidly.

NOTE:

The actual parameter being modified in EDIT mode doesn't change until the new data is saved by pressing the ENTER key twice.

5. Press ENTER when the desired value displays. This accesses an additional display, giving the operator a chance to back out of the programming mode (ESCAPE) and not save the new value. To accept and save the new value to memory, press ENTER.
6. Once the value is entered into memory, the display returns to the Setup Menu. You may now check and view the new value or select additional parameters to modify.

If an incorrect value is accidentally entered, repeat the above process and enter the proper value; or select the Set Defaults menu selection on the Setup Menu and press ENTER twice to reset all parameters to their factory default values.

NOTE:

The Set Defaults menu selection will not reset Standby Time, Standby Events, Device Address, or Total Runtime; the operator must manually reset these settings.

In addition to increasing or decreasing numerical values with UP and DOWN, the operator can select ON or OFF and YES or NO. These are selected and entered as described above. The PIM Option, CODE VER, VMX_CLASS VER, and Total Run Time selections are informational display only items and cannot be edited. To return to the "Operation Normal" menu from the Setup Menu, press ESCAPE three times.

5.0 Operation, continued

5.2 Smart Display, continued

5.2.3 Setup Menu, continued

The Setup Menu contains the following items:

Top Line (provides additional information)

- SET UP MENU
- ↕ TO MANUAL SCROLL
- <ESC> TO ADD'L INFO

Second Line (cycles through the following parameters):

	Default	Minimum	Maximum
Float V/C	2.27	2.1V/Cell	2.35V/Cell
Accept V/C	2.40	2.2V/Cell	2.45V/Cell
Temp Comp	5mV/Cell/°C	0mV/Cell/°C	5mV/Cell/°C
Battery Capacity*	100Ah	0Ah	1000Ah
Self-test	Off	On	Off
Test Inhibit	N/A	7 days	7days
Test Interval	30 days	0 days	360 days
Test Countdown	0 days	0 days	360 days
Test Duration	10 minutes	5 minutes	180 minutes
Frequency Range	3Hz	1Hz	6Hz
Reset Out 1		No	Yes
Reset Out 2		No	Yes
Reset Out 3		No	Yes
Reset Out 4		No	Yes
Peak Current 1	Rating of the unit (15A or 22A)	3A	25A
Peak Current 2	Rating of the unit (15A or 22A)	3A	25A
Peak Current 3	Rating of the unit (15A or 22A)	3A	25A
Peak Current 4	Rating of the unit (15A or 22A)	3A	25A
RMS Current 1	Rating of the unit (15A or 22A)	3A	25A
RMS Current 2	Rating of the unit (15A or 22A)	3A	25A
RMS Current 3	Rating of the unit (15A or 22A)	3A	25A
RMS Current 4	Rating of the unit (15A or 22A)	3A	25A
Peak Retry Delay	60s	5s	301s
Peak Retry Limit	10	0 (retry disabled)	40
Peak Current Tolerance	40ms	20ms	9900ms
RMS Retry Delay	300s	60s	600s
RMS Retry Limit	10	0	10
RMS Current Tolerance	60s	Read Only	Read Only
Standby Time	0 minutes	0 minutes	65,535 minutes
Standby Events	0 events	0 events	65,535 events
Set Defaults	No	No	Yes
Code Version	2.00.0		
VMX_Class Version	6		
Device Address	1	0	7
Total Runtime	0 days	0 days	65,535 days
Language	English	Spanish, French, German, Portuguese	
* 100Ah = 1 battery string, 200Ah = 2 battery strings, 300Ah = 3 battery strings			

Table 5-1, Setup Menu Parameters



NOTE:

Refer to Section 5.3, Smart Display Glossary, for descriptions of the setup menu parameters.

5.0 Operation, continued

5.2 Smart Display, continued

5.2.3 Setup Menu, continued

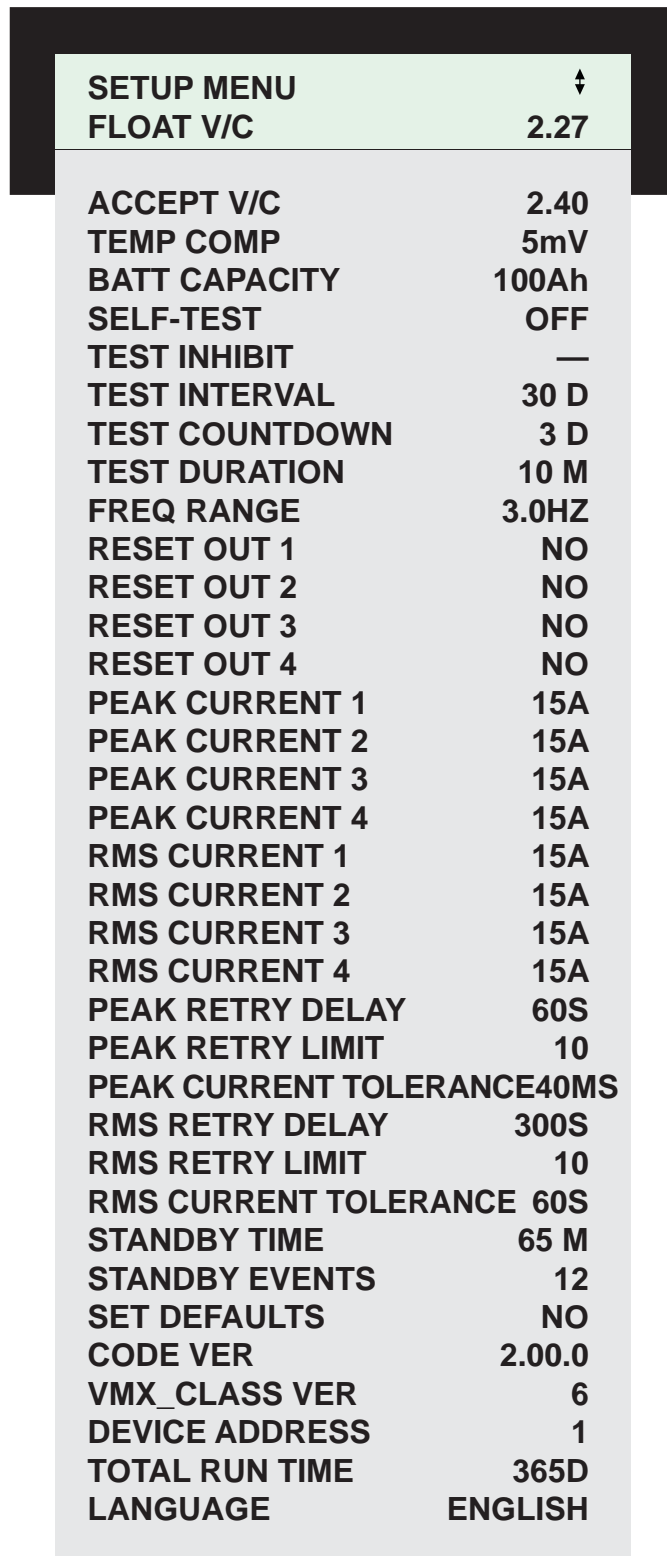

SETUP MENU	↕
FLOAT V/C	2.27
ACCEPT V/C	2.40
TEMP COMP	5mV
BATT CAPACITY	100Ah
SELF-TEST	OFF
TEST INHIBIT	—
TEST INTERVAL	30 D
TEST COUNTDOWN	3 D
TEST DURATION	10 M
FREQ RANGE	3.0HZ
RESET OUT 1	NO
RESET OUT 2	NO
RESET OUT 3	NO
RESET OUT 4	NO
PEAK CURRENT 1	15A
PEAK CURRENT 2	15A
PEAK CURRENT 3	15A
PEAK CURRENT 4	15A
RMS CURRENT 1	15A
RMS CURRENT 2	15A
RMS CURRENT 3	15A
RMS CURRENT 4	15A
PEAK RETRY DELAY	60S
PEAK RETRY LIMIT	10
PEAK CURRENT TOLERANCE	40MS
RMS RETRY DELAY	300S
RMS RETRY LIMIT	10
RMS CURRENT TOLERANCE	60S
STANDBY TIME	65 M
STANDBY EVENTS	12
SET DEFAULTS	NO
CODE VER	2.00.0
VMX_CLASS VER	6
DEVICE ADDRESS	1
TOTAL RUN TIME	365D
LANGUAGE	ENGLISH

Fig. 5-4, Setup Menu Display
(Examples are given for values in the display)

5.0 Operation, continued

5.2 Smart Display, continued

5.2.4 Alarm Indications

In the event of a failure, the Active Alarm display indicates detected alarms and items to check to correct the alarm condition. Major alarms also cause the red LED to flash. Press either UP or DOWN to stop Auto Scroll. The arrows appearing at the right-hand side of the display text indicate keys to press to show the next item in the menu. Use UP or DOWN to select the alarm of interest. Press ENTER to select the alarm and display diagnostic information. Press ESCAPE to return to the alarm list.



NOTE:

If only one alarm is active, the alarm list is bypassed and the display shows diagnostic information for the single active alarm.

To assist the operator in troubleshooting an active alarm condition, a Help sub-menu offers possible remedies relating to the displayed alarm. To access the Active Alarm Help sub-menu, scroll to the alarm of interest and press ENTER. The diagnostic information autoscrolls initially. Enter manual scroll mode by pressing either UP or DOWN. Press DOWN to scroll through the list of remedies.

Alarms are classified in two categories:

Major Alarms are indications of a serious failure within the VMX Power Supply, such as a loss of output voltage or a failed battery charger. Any situation that causes output failure is considered a Major Alarm. Major alarms require immediate action by the operator to correct the failure. To correct major alarms, follow the Smart Display on-screen instructions.

Minor Alarms indicate a less serious failure, such as defective RTS or loss of utility power. Corrective action can be delayed for a short time. To correct, follow the Smart Display on-screen instructions.

The alarm matrices on the following pages indicate the MAJOR/MINOR active alarms, the probable cause, and troubleshooting items to check to correct the alarm condition.

5.0 Operation, continued

5.2 Smart Display, continued

5.2.4 Alarm Indications, continued

Major Alarms		
Active Alarm	Corrective Action	Probable Cause
Self-test FAIL*	<ol style="list-style-type: none"> 1. Check batteries 2. Check inverter 	<ul style="list-style-type: none"> • 36V battery string below 33.3Vdc • 48V battery string below 44.3Vdc • Inverter failure • Batteries will not sustain load
LOW BATT VOLTS	<ol style="list-style-type: none"> 1. Shutdown imminent 2. Check AC input 3. Connect generator 	36V battery string below 33Vdc 48V battery string below 44Vdc
HIGH BATT VOLTS	<ol style="list-style-type: none"> 1. Check charger settings 	36V battery string above 45.0Vdc 48V battery string above 60Vdc
NO BATTERIES	<ol style="list-style-type: none"> 1. Check battery breaker 2. Check connections 3. Check battery fuse 	Absence of batteries detected (alarm is inactive when battery capacity is set to 0)
LINE ISOLATION**	<ol style="list-style-type: none"> 1. Replace power supply 	Line isolation has failed. All inverter operations are suspended
OUTPUT FAIL	<ol style="list-style-type: none"> 1. Check configuration switches 2. Output overloaded? 	The AC output has failed (check configuration)
OUTPUT OVERLOAD	<ol style="list-style-type: none"> 1. Check configuration switches 2. Output short circuit? 3. Excessive load 4. Check output current 	The VMX is overloaded
CHARGER FAILURE	<ol style="list-style-type: none"> 1. Perform self-test 	Charger has failed or shutdown, possible battery over-temperature
INVERTER TEMP	<ol style="list-style-type: none"> 1. Check fan 	Inverter heatsink has exceeded set temperature (Standby operations are suspended until temperature drops to safe level)
CONFIG ERROR	<ol style="list-style-type: none"> 1. Check configuration switches 2. Check Inverter 	The VMX is improperly configured. Operation is suspended until error is corrected.
* To clear a Latched Self-test Fail Alarm, initiate and complete a successful self-test. ** Remove and replace VMX Power Supply. Do not try to clear alarm.		

Table 5-2, Major Alarms

Minor Alarms		
Active Alarm	Corrective Action	Probable Cause of Alarm
BATT TEMP PROBE	<ol style="list-style-type: none"> 1. Check connection 2. Check sensor 3. Input connections 	Remote Temp Sensor (RTS) failed, or is not connected
INPUT FAILURE	<ol style="list-style-type: none"> 1. Utility failure 2. Circuit breaker input 	Utility AC input has failed

Table 5-3, Minor Alarms

5.0 Operation, continued

5.2 Smart Display, continued

5.2.5 Control Panel LEDs

Two front panel LEDs indicate the condition and status of the VMX Power Supply. The green Output LED, when illuminated, indicates the power supply is functioning normally and supplying output AC to the load. A flashing output LED indicates that a minor alarm has been detected. If the Output LED is off, a major alarm has been detected.

The red Alarm LED either flashes or is off depending on the operating state of the power supply. A flashing Alarm LED indicates that a major alarm has been detected. This state clears when the alarm is no longer present. Normally, the red Alarm LED is OFF indicating normal power supply operation.

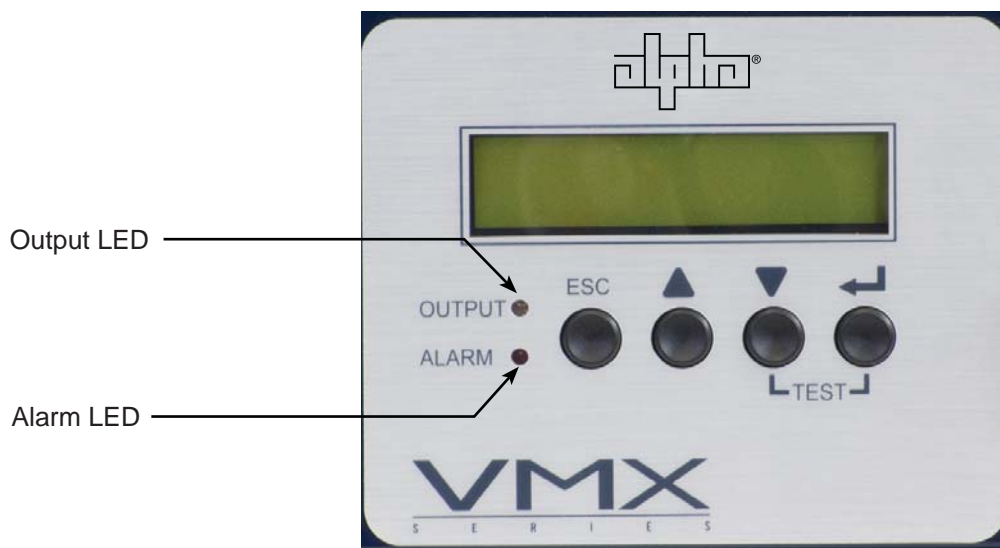

Fig. 5-5, Smart Display LEDs

Major Alarms are indications of a serious failure within the VMX Power Supply, such as a loss of output voltage or a failed battery charger. Any situation that causes the output to be off can be considered a Major Alarm. Any Major Alarm, when encountered, requires immediate action to be taken by the operator to correct the failure. To correct, simply, follow the Smart Display on-screen instructions.

Minor Alarms indicate a less serious failure, such as defective RTS or loss of utility power. Corrective action can be delayed for a short time. To correct, simply, follow the Smart Display on-screen instructions.

5.2 Smart Display, continued

5.2.6 Detailed Menu Structure and Navigation

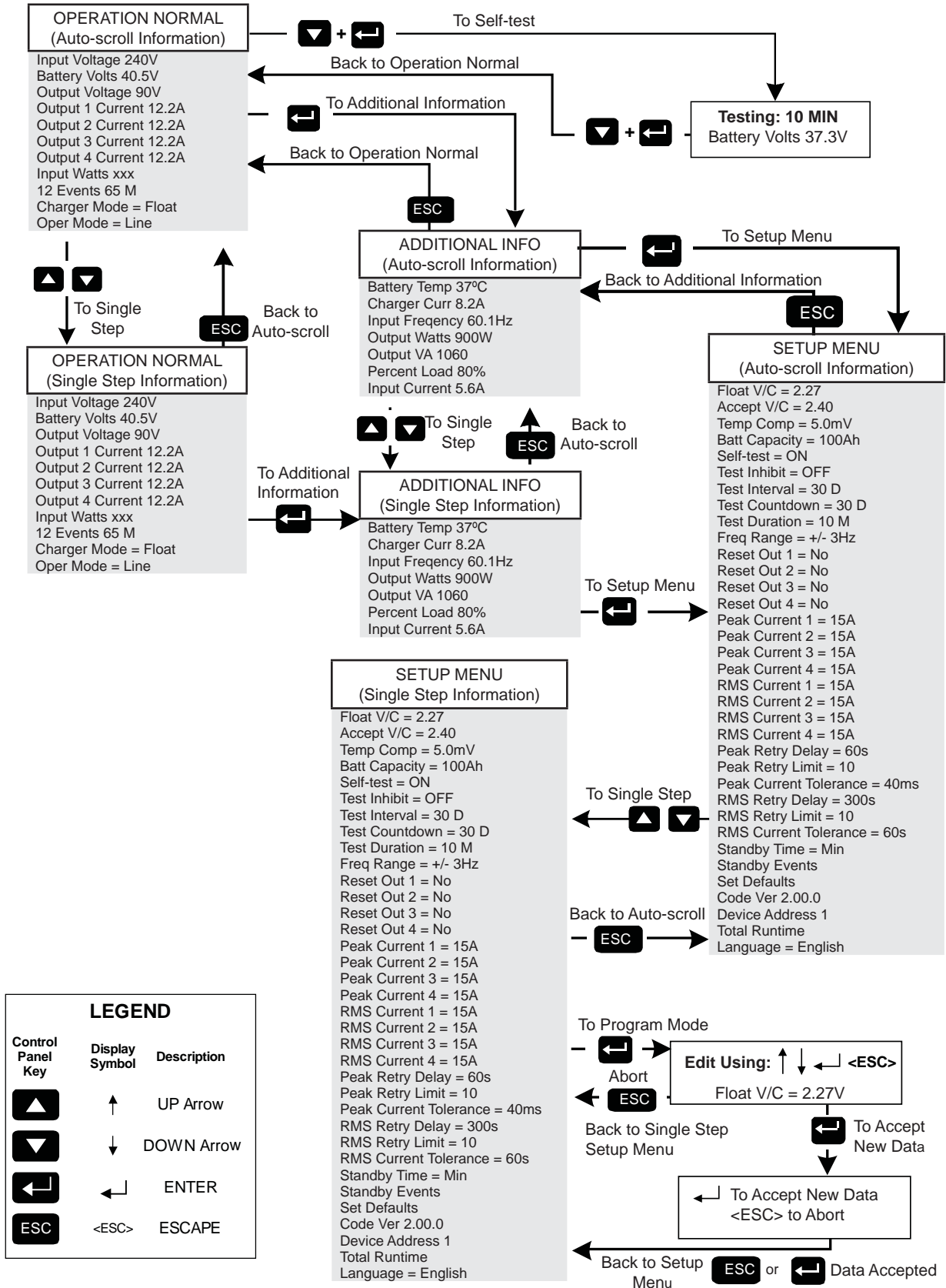

5.2 Smart Display, continued

5.2.6 Detailed Menu Structure and Navigation, continued

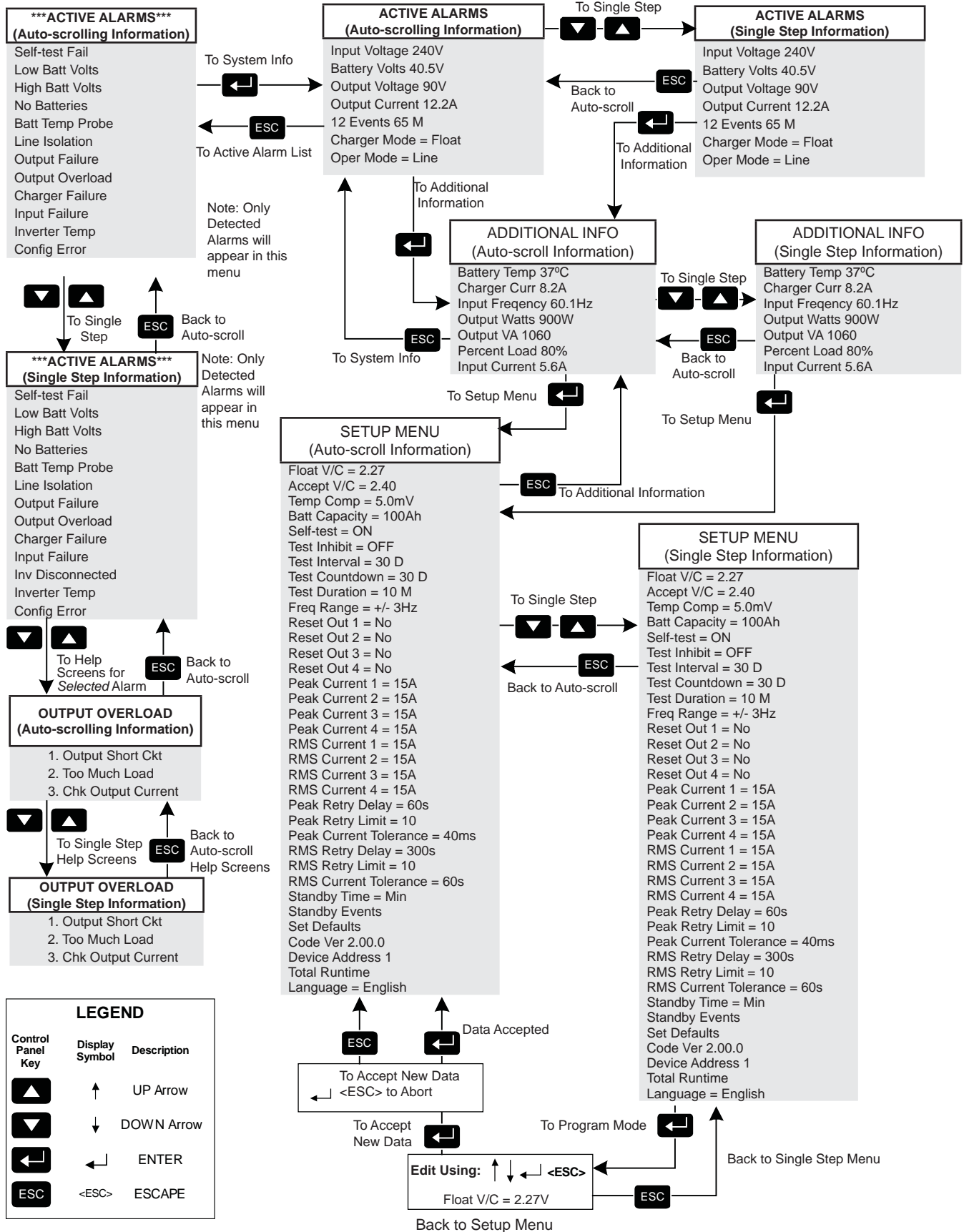

5.0 Operation, continued

5.3 Smart Display Glossary

Battery Capacity: The capacity of the battery strings attached to this VMX Power Supply. When batteries are not attached, the setting may be programmed to “0.” This disables standby operations, including test mode, and disables the No Batteries Alarm. If batteries are attached, then this setting should be programmed to the total rating of all battery strings. This setting can be programmed to higher values to accommodate multiple battery strings (i.e., 1 battery string = 100Ah, 2 battery strings = 200Ah, 3 battery strings = 300Ah).



NOTE:

If an VMX Power Supply is used in a non-standby application, this variable must be programmed to “0” to disable the battery maintenance cycle portion of a self-test.

BULK charge is a “Constant Current” charge. The maximum charger current is 10 Amps. As the charge is returned to the batteries, their voltage increases to a specific threshold (2.27Vdc per cell). This cycle ends when the charging current into the batteries becomes less than 0.5A. The charger then switches to ACCEPT mode. The BULK charger mode generally returns the battery charge state to 80 percent of rated battery capacity.

Charger Accept Voltage: Battery Accept charge voltage control in volts per cell. This voltage, 2.40Vdc (adjustable) per cell, is temperature compensated to assure longer battery life. It properly completes the charge cycle and is factory set for Alpha Cell batteries. If other manufacturer’s batteries are used, consult the battery manufacturer for Accept voltage levels.

Charger Float Voltage: Battery Float charge voltage control in volts per cell. It averages about 2.27Vdc (adjustable) per cell. It is factory set for Alpha Cell batteries. If other manufacturer’s batteries are used, consult the battery manufacturer for Float voltage levels.

Charger Temperature Compensation: Battery charger temperature compensation control. Programming this parameter to “0.0” will disable temperature compensation. It is factory set for Alpha Cell batteries (5mV/cell/°C). If other manufacturer’s batteries are used, consult the battery manufacturer for Charger Temperature compensation ranges.

Device Address: The VMX Power Supply must have a unique address to communicate with a system controller. The system controller uses the address as an identifier to query the VMX Power Supply for information. Each VMX Power Supply on the same communications bus must be identified with a value between 1 and 7.



NOTE:

The device address will not reset to 1 when factory defaults are reset.

End of Battery Discharge (EOD): The point at which the batteries are fully discharged (1.75V/C°, 18 cells for 36V inverter; 24 cells for 48V) and the power supply shuts off, preventing permanent damage to the batteries.

Frequency Range Limit (may be used when powering with AC Generator): AC input voltage frequency range limit. This limit establishes the acceptable input frequency range outside of which standby operation is initiated.

Set Defaults: When programmed by the operator to YES, all the programmable data levels (except DEVICE ADDRESS, Standby Time and Events, and Language) are reset to the original factory settings.

Self-test: When programmed by the operator to YES, the VMX Power Supply will test inverter operation.

Standby Events: VMX Power Supply standby events counter. This does not include self-test events. Use the Setup Menu to reset Standby Events to zero.

5.0 Operation, continued

5.3 Smart Display Glossary, continued



NOTE:

Resetting factory defaults does not clear Standby Events or Standby Time.

Standby Time: The total amount of time the VMX Power Supply has operated in standby mode. This does not include self-test time and thus represents the sum total number of minutes of AC line failure since the last time this counter was reset. Use the Setup Menu to reset Standby Time to zero.

Test Countdown: The number of days remaining before the next scheduled automatic self-test is initiated. This variable is programmable and allows the operator to select the day that the autotest sequence will begin. This counter has no effect if test interval is set to 0.

Test Duration: Automatic self-test duration timer. The number of minutes the VMX Power Supply performs battery maintenance cycle test. This timer applies to initiated tests automatically or manually.

Test Inhibit: Becomes active when programmed by the operator (or when the unit runs in inverter mode for more than 5 minutes). The VMX Power Supply delays the start of a scheduled self-test for seven days if the test countdown is less than seven days (See Section 5.4, Automatic Performance Test for complete details).

Test Interval: Automatic self-test control timer. The number of days between battery maintenance cycle tests. Setting this value to zero disables automatic self-test.

Total Run Time: The amount of time (in days) the power supply has functioned in any mode of operation. This is not a re-settable value.

5.0 Operation, continued

5.4 Automatic Performance Test

Automatic Self-test: The VMX Power Supply can periodically perform an automatic self-test to verify the state of the batteries and the inverter circuitry. The automatic test feature has several programmable parameters that affect the frequency and duration of automatic tests. In addition to automatic testing, you can manually put the VMX Power Supply into test mode by pressing ENTER and DOWN simultaneously. A running test may be halted manually by pressing ENTER and DOWN a second time.

The test sequence starts with a check to verify that batteries are attached and the battery circuit breaker is closed. If the batteries are discharged or not connected, the VMX Power Supply does not attempt to operate in inverter test mode, and thus not drop the load if the inverter does not have sufficient batteries to operate. Next, the VMX Power Supply switches to standby mode for a pre-programmed period. Successful completion of a test sequence means that the VMX Power Supply operated normally in standby mode, the battery voltage didn't drop below a preset threshold and the output was stable throughout the test. Failure of a test is indicated by a Self-test Fail alarm, which can be cleared by subsequently running a successful test for at least one minute.

Test Control: A manual test may be initiated (or a running test may be halted) at any time by pressing ENTER and DOWN simultaneously or by changing the Self-test switch via the front panel interface or status communications. A self-test may also be started via the status monitoring card.

To prevent an automatic test that is scheduled to occur in the next week, issue a Test Inhibit command. This command is useful if periodic maintenance is scheduled to occur on the power supply near the time that the next automatic test is to start. This control feature may also be used when inclement weather is expected that may cause a utility failure. The Test Inhibit command only affects an automatic test scheduled to run in the next seven days. Multiple issues of the Test Inhibit command will result in the deferral of the next automatic test until at least seven days after the last request. This command has no effect if an automatic test is not scheduled to take place in the next week. Starting a test manually overrides the Test Inhibit command.

The automatic test feature is on by default, but may be turned off. To turn auto-test off, change Test Interval to 0 days in the Setup Menu. Auto-test may be enabled at any time by changing the test interval to any nonzero value. The default test interval is 30 days.

Test Countdown: Informs the operator of a pending automatic test, or allows the operator to schedule the next automatic test.

Test Duration: Test Duration can be adjusted to meet the customer's needs. Exercise caution when increasing the parameter because long self-tests compromise the standby capability during, and shortly after, the test.

Standby Time and Standby Events: Counters that are not incremented during VMX Power Supply self-tests.

5.0 Operation, continued

5.5 Providing Power via External Source

In the event of an extended utility failure, an external AC or DC power source can provide backup power to the system. The backup power source allows the power supply to continue charging the batteries, and ensures uninterrupted service to the network. Follow the procedures outlined in the documentation and/or connection procedures listed below.

5.5.1 DC Powering

A convenient method of providing backup DC power to the network is the AlphaGen Portable Generator. On loss of commercial AC power, the existing battery string(s) immediately supply voltage to the inverter. After some point of battery discharge, an operator can deploy the portable generator to the site to supply power to the DC bus. *Refer to the AlphaGen Portable Generator Operator's Manual, Alpha P/N 041-028-B0, for complete connection and operation information.*

5.5.2 AC Powering

Should it become necessary to power your network with a portable AC generator, truck-mounted AC generator, or truck-mounted inverter, the procedures below must be followed for the protection of service personnel and system powering equipment.

Connection Procedure:

1. Determine if there is output power to the cable system by reading the Smart Display. If there is still power to the system then check the battery voltage on the Smart Display. If the battery voltage is greater than 34.5Vdc (3-battery system) or 46Vdc (4 battery system) then approximately one hour remains to complete the changeover to generator power before the cable system loses customer power. If the battery voltage is less than the previous numbers, move rapidly as there is not much time until system failure. Use extreme caution, there are dangerous voltages in the system that can shock you or damage the cable amplifiers.
2. Verify the AC Input breaker from the utility powering system is in the OFF position. This ensures that if power returns suddenly, both you and the system will not experience a surge in power, and that when you connect the generator, it does not put AC voltage back onto the power lines.
3. Properly ground the generator. This is accomplished by connecting a #6 AWG wire from the grounding lug on the output panel of the generator to either a driven ground rod or the strand ground on the pole to which the power supply is mounted. If working with a ground-mounted power supply, locate the grounding point inside the enclosure and clamp on to that point.



Grounding of the generator is *mandatory* for safety and for proper operation of the power supply.

4. After properly grounding the generator, unplug the power supply from the convenience outlet inside the enclosure and plug the power supply input cable into the generator output. An approved extension cord must be used.

5.0 Operation, continued

5.5 Providing Power via External Source, continued

5.5.2 AC Powering, continued

5. Start and operate the generator according to the generator operation manual.
6. If the generator kilowatt rating is twice the kilowatts used by the power supply indicated on the Smart Display, leave the battery breaker on and the generator will charge the batteries. If the generator fails the power supply will continue to provide battery backup. If the generator output is not approximately twice the kilowatt rating indicated on the Smart Display, switch the battery breaker off (this reduces the load on the generator but battery backup of the system is unavailable).
7. In either case, after the power from the generator is applied to the power supply, use the Smart Display to increase the Frequency Input Tolerance to $\pm 6\text{Hz}$ from the normal $\pm 3\text{Hz}$. This limits the power supply from switching to battery backup if the generator occasionally does not operate on the proper frequency. It is not uncommon for smaller (4 kilowatt or less) sized generators to get “off frequency” due to the step loading of the power supply.

5.5.3 Using a Truck-mounted Inverter or Generator



WARNING!

Ground the vehicle before operating the truck inverter or truck-mounted generator. Failure to do so will place service personnel at risk for electric shock.

To use a truck-mounted inverter or generator follow the steps listed in Section 5.5.2 with the additional step of grounding the truck. Run the ground wire from an unpainted point on the truck chassis to either a driven ground rod or strand ground to complete the grounding circuit. The rubber tires on the truck insulate it from being grounded in all but the most exceptional circumstances.

5.0 Operation, continued

5.6 Resumption of Utility Power



WARNING!

Use caution when disconnecting a generator and reconnecting to utility power. Dangerous voltages are present.



CAUTION!

Care must be exercised to ensure that both powering systems are not connected at the same time, or damage to the power supply and/or the generator may result.

1. Use a voltmeter to verify the input voltage is within specifications before turning on the AC voltage input breaker.
2. Once the proper voltage is present, verify the battery voltage indicated on the Smart Display is greater than 31.5V for a 36V system, or 42V for a 48V system. Disconnect the power supply from the generator output and plug the power supply input cord into the convenience outlet within the enclosure. The power supply operates on battery backup for a short period of time. Exercise caution during this changeover. The grounding circuit to the power supply is broken while in the act of unplugging and reconnecting the power supply.

If the batteries are at or below the low voltage cutoff, the power supply will not transfer to battery back-up and there will be a momentary power outage to the cable system while you make this changeover.

3. Turn on the AC input power.
4. Shut down the generator and remove the grounding system.

6.0 VMX Power Supply Maintenance

Maintenance must be performed every three to six months. By establishing a routine maintenance program, and following the guidelines contained in this manual, the VMX Power Supply will provide years of trouble-free operation.

Care of the batteries is the first step in any power supply maintenance program. In addition to voltage checks, visually inspect the batteries for signs of cracking, leaking, or swelling. To aid in quick identification and tracking of voltages in the maintenance log, number the batteries inside the enclosure using labels or masking tape, etc. Batteries are temperature sensitive and susceptible to overcharging and undercharging. Since batteries behave differently in the winter than in the summer, Alpha's battery chargers automatically compensate for changes in temperature by adjusting float and accept charge voltages.



CAUTION!

- The VMX Power Supply must be serviced by qualified personnel.
- Alpha Technologies is not responsible for battery damage due to improper charger voltage settings. Consult the battery manufacturer for correct charger voltage requirements.
- When removing batteries, ALWAYS switch the battery breaker off before unplugging the battery connector.
- Always wear safety glasses when working with batteries.

6.1 Check Battery Open Circuit Voltage

Prior to testing, record the battery manufacturer, date code, lot number, and power supply's model number and serial Number.

Inspect all battery posts, verify that all connections are clean and tight. Reapply corrosion inhibitor.

Disconnect the AlphaGuard CMT (if used) and switch the front panel battery breaker of the VMX Power Supply Inverter to OFF. Disconnect the battery connector from the inverter and measure the individual voltage across each battery. The difference between any battery in the string should not be greater than 0.3Vdc. Defective or marginal batteries should be replaced with an identical type of battery. Record the unloaded battery voltages in the maintenance log.

6.2 System Information

Observe and record the following system information from the Normal Operation and Additional Information menus in the maintenance log. See Section 6.9.

Operation Normal
Input Voltage
Output Voltage
Output Current (1-4)
Standby Events
Battery Voltage
Charger Mode
Total Standby Time
Operation Mode

Additional Information
Battery Temperature
Output Voltage
Input Frequency
Output Watts
Output VA
Percent Load

6.0 VMX Power Supply Maintenance, continued

6.3 Check Battery Voltage Under Load

In order to completely verify a battery's ability to supply load, the battery must be tested while under a load. This is the most accurate method to determine the condition of the batteries. If available, use a battery load tester and follow the manufacturer's instructions to test the individual batteries. If a battery load tester is not available, use the following procedure.



WARNING!

Weak or severely discharged batteries can explode when put under load. As an added safety precaution, place the enclosure's door between the operator and batteries before attempting standby operation.



NOTE:

- If installed, disconnect the AlphaGuard–Charge Management Technology Card (AG-CMT) prior to measuring battery voltage.
- Even with an AG-CMT present, any battery which fails the 0.3V load test must be replaced with an identical type of battery.

Test Procedure:

1. If the batteries appear functional (i.e., if they have passed “Check Battery Open Circuit Voltage” test), reconnect the Battery Input connector to the Inverter Module, switch on the battery breaker, and wait for the No Batteries alarm to reset.
2. Simultaneously press ENTER and DOWN on the Smart Display to manually start an inverter self-test.



NOTE:

The VMX Power Supply will not go to self-test if the batteries are defective or disconnected. Initially, the battery voltage will appear to drop quickly (this is “surface” charge), but the battery voltage should stabilize quickly.

3. When the battery voltage appears to stabilize (approximately 8-10 minutes), use a multimeter to measure individual battery voltages under load.
4. The difference between any of the batteries should not be greater than 0.3Vdc. Replace defective or marginal batteries with an identical type of battery.
5. Record the loaded battery voltages in the maintenance log.

6.0 VMX Power Supply Maintenance, continued

6.4 Check Battery Charger Voltage

The advanced three-stage charging features of the VMX Power Supply are completely self-monitoring. During normal power supply operations, the power supply continuously verifies the operating condition of the battery charger. If, for any reason, the battery charger fails, a Charger Fail alarm displays on the Smart Display. No operator voltage checks are required.

6.5 Check Battery Terminals and Connecting Wires

Check each battery terminal and connection. Verify the posts are clean and the crimped connectors are tight. Terminal connectors should be torqued in accordance with the battery manufacturer's recommendation. If there is an in-line fuse in the battery cable, check the fuse holder and fuse. Verify the terminals are properly protected with an approved battery terminal corrosion inhibitor such as NCP-2. Record date of maintenance in the maintenance log.



NOTE:

Whenever the battery breaker is turned off, or the batteries are not connected, the VMX Power Supply automatically reports a No Batteries alarm. This is normal, and is a built in safety feature. The unit does not attempt inverter operations, either standby or test, during a No Battery alarm.

6.6 Check Output Voltage

Measure the AC output voltage at the VMX Power Supply Transformer Module's Output test points using a true RMS AC voltmeter. Only use a True RMS meter, as other meters may not give a correct reading.

Output voltages should appear within $\pm 5\%$ of rated output at a nominal line input.

Record the voltages in the maintenance log. Output voltages can also be observed by using the Smart Display.

Setting	Low (-5%)	High (+5%)
87Vac	82.65Vac	91.35Vac
63Vac	59.85Vac	66.15Vac
48Vac	45.60Vac	50.40Vac

6.7 Check Output Current

With the VMX Power Supply in normal operating mode, observe the Output current values indicated by the Smart Display. The values of output current will be dependent on the total amount of load connected to each output of the power supply. Record the current in the maintenance log.

6.0 VMX Power Supply Maintenance, continued

6.8 Replacing the Metal Oxide Varistors

The Power Distribution Board (PDB) uses three Metal Oxide Varistors (MOVs) for lightning suppression. If the MOVs fail, Alpha offers a replacement board option to bring the unit back into service.

Tools Required: #2 Phillips screwdriver
Wire cutters

WARNING!

Before proceeding, verify all power has been removed from the power supply by unplugging the power supply from the AC power source and disconnecting the battery connector. Failure to do so could expose the technician to potentially lethal voltages.

NOTE:

Use a backup power source at this time as the VMX will not provide any power during this procedure.

Procedure:

1. Remove all power to unit. Turn off battery breaker and unplug battery connector. Unplug line cord and remove all front panel connectors.
2. Remove the screws securing the power supply front panel. Set the screws aside in a safe location.
3. Tip the front panel forward to gain access to the Power Distribution Board.
4. Remove the damaged MOVs using your wire cutters. See Fig. 6-1.
5. Replace with the MOV replacement card option (Alpha P/N 704-804-20). Position the card over P3, P9, and P8 and seat firmly as shown in Fig. 6.2.
6. Replace the front cover.

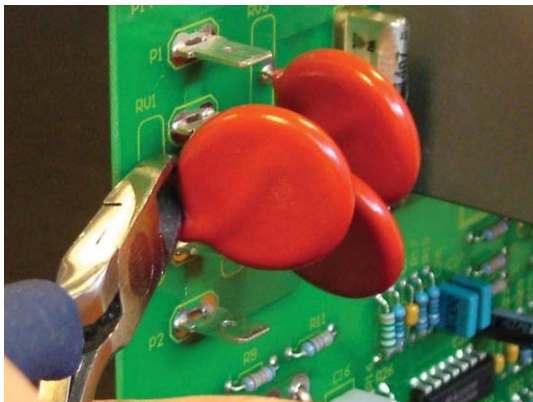

Fig. 6-1, MOV Removal

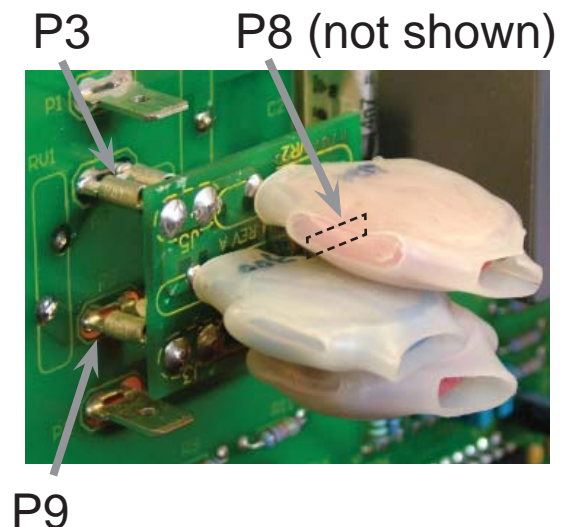

Fig. 6-2, MOV Replacement

6.0 VMX Power Supply Maintenance, continued

6.9 Maintenance Log

Battery Maintenance								
Battery Number	1	2	3	4	5	6	7	8
Battery Manufacturer								
Date Code/Lot Number								
Terminal Check								
Voltage (Unloaded)								
Voltage (Loaded)								

VMX Maintenance	
Model Number	
Serial Number	

Normal Operation	
Input Voltage	
Output Voltage	
Output Current (1-4)	
Battery Voltage	
Standby Events	
Standby Time	
Charger Mode	
Operation Mode	

Additional Information	
Battery Temperature	
Charger Current	
Input Frequency	
Output Watts	
Output VA	
Percent Load	

Commissioning	
Service Technician	
Date Serviced	

7.0 Specifications

Model:	VMX 615CE		VMX 622CE-48		VMX 915E	
Electrical						
Input Voltage:	230Vrms		230Vrms		230Vrms	
Input Tolerance:	Operating: ±158 to 292Vrms Line Return: ±169 to 281Vrms		Operating: ±158 to 292Vrms Line Return: ±169 to 281Vrms		Operating: ±158 to 292Vrms Line Return: ±169 to 281Vrms	
Nominal Input Current ¹ :	5A		7A		7A	
Input Frequency:	50Hz, ±3Hz		50Hz, ±3Hz		50Hz, ±3Hz	
DC Voltage:	36VDC		48VDC		36VDC	
Low DC Voltage Cutout:	1.75V/Cell		1.75V/Cell		1.75V/Cell	
Output Voltage:	63V rms		48/63V rms (Field Selectable)		63/87V rms (Field Selectable)	
Output Regulation, High TAP ² :	±3%		±3%		±3%	
Output Regulation, Low TAP ² :	±4%		±4%		±4%	
Rated Output Current:	15A rms		22A rms		15A rms	
Output Configuration:	4 Programmable Outputs		4 Programmable Outputs		4 Programmable Outputs	
Output Frequency:	50Hz, ±1Hz (Inverter Operation)		50Hz, ±1Hz (Inverter Operation)		50Hz, ±1Hz (Inverter Operation)	
Waveform:	Quasi Square wave		Quasi Square wave		Quasi Square wave	
Slew Rate:	<200 V/ms, <100 V/ms typical		<200V/ms, <100V/ms typical		<200V/ms, <100V/ms typical	
Crest Factor Ratio (Peak: RMS):	1.3:1 typical		1.3:1 typical		1.3:1 typical	
Auxiliary Output 150W rated UPS:	205-260V (line), 170-265V (Inv)		205-260V (line), 170-265V (Inv)		205-260V (line), 170-265V (Inv)	
Efficiency @ Default TAP Settings						
@100% Load:			91% typical at nominal input			
@75% Load:			90% typical at nominal input			
@50% Load:			88% typical at nominal input			
@25% Load:			80% typical at nominal input			
On Inverter (40 to 100% load):			80% typical			
Overload Protection						
Fold back (Typical @ Nominal Input)						
87V TAP:	N/A		N/A		24A rms	
63V TAP:	33A rms		35A rms		33A rms	
48V TAP:	N/A		45A rms		N/A	
Output Current Into Short (@ Nominal Input)						
87V TAP:	N/A		N/A		<22.5A rms	
63V TAP:	29A rms typical		<30A rms		29A rms typical	
48V TAP:	N/A		<33A rms		N/A	
Overload Current Operation						
0% to 110% Load:			Continuous Operation			
110 to 115% Load:			Continuous Operation with Alarm			
115 to 125% Load:			Shut Down approx. 30min			
125 to 150% Load:			Shut Down approx. 10min			
>150% Load:			Shut Down <10sec			
Battery Charging						
Charge Current ³ :			10A			
Temperature Compensation:			-5mV/Cell/°C (Programmable)			
Constant Current Operation:			High Rate Charge to 90% Capacity			
Constant Voltage Operation:			2.40V/Cell (Programmable)			
Environmental						
Operating Range:			-40 to 55°C at Front Air Inlet of Power Supply			
Humidity:			0 to 95% non-condensing			
Altitude:			0 to 10000ft (3000m) above sea level			
Mechanical						
	Vertical Mount	Shelf Mount	Vertical Mount	Shelf Mount	Vertical Mount	Shelf Mount
Height (in/mm):	11.7/297	8.4/212	11.7/297	8.4/212	11.7/297	8.4/212
Width (in/mm):	20/508	16.5/420	20/508	16.5/420	20/508	16.5/420
Depth (in/mm):	9/229	12.5/317	9/229	12.5/317	9/229	12.5/317
Weight (lbs/kg):	67/30.5	67/30.5	67/30.5	67/30.5	67/30.5	67/30.5
Front Panel Display (LCD):	2 x 20 Character LCD		2 x 20 Character LCD		2 x 20 Character LCD	
Front Panel Indicators (LED):	Output Status & Alarm		Output Status & Alarm		Output Status & Alarm	
Finish:	Dark Blue Powder Coat		Dark Blue Powder Coat		Dark Blue Powder Coat	
Communication						
Status Monitoring ⁴ :			Optional ESM/DSM			
Agency						
Safety Recognition:	EN 50091-1-2, IEC 60950, CB Scheme. CE				EN 50091-1-2, IEC 60950, CB Scheme.	
Emissions:			EN 50091-2, CE Class A			
Notes:						
¹ Batteries fully charged						
² Output regulation at nominal input frequency. Frequency variations will proportionally affect the output voltage (i.e., a 1% reduction in frequency will result in approximately a 1% drop in output voltage)						
³ Varies with input line voltage and output load. ⁴ Status monitoring and embedded transponders are optional.						

7.0 Specifications, continued

7.1 Safety and EMC Compliance

European Union Product Compliance:	
Safety (CE):	
Low Voltage Directive:	72/23/EEC, 93/68/EEC
Technical Standards:	EN 50091-1:1993, EN 60950:1992
Electromagnetic Compatibility (EMC):	
EMC Directive:	89/336/EEC, 92/31/EEC, 93/68/EEC
Technical Standards:	EN 50091-2:1996

8.0 Troubleshooting

The Smart Display troubleshooting guide is designed to display typical symptoms, causes and solutions, starting with the most obvious and working systematically through the VMX Power Supply. Alpha Technologies recommends that the power supply's maintenance log accompany units brought in for bench service to aid the operator in troubleshooting the problem.

8.1 Return/Repair Information

In the event the Power Supply must be returned to Alpha Technologies for service, a Return Material Authorization (RMA) form must accompany the unit. The form can be found at Alpha's Web site (www.alpha.com/support). Follow the instructions contained in the form to obtain an RMA. Once an RMA number has been issued, pack the unit per instructions and return to the service center assigned by Alpha Technologies. Or, if preferred, contact Alpha Technologies at (800) 322 5742 for assistance.



NOTE:

Any information pertaining to the nature of the power supply failure or problem, along with a copy of the power supply's maintenance log, should be included with the returned VMX Power Supply.

8.2 Parts Ordering Instructions

When ordering parts from Alpha Technologies, contact the Customer Service Department directly:

Asia Pacific	+1 (360) 647 2360	Middle East	+357 25 375675
Canada	+1 (604) 430 1476	Germany	+49 9122 79889 0
Latin America	+1 (360) 647 2360	United States	+1 (360) 647 2360
United Kingdom	+44 1279 501110		

8.0 Troubleshooting, continued

8.3 Emergency Shutdown

The VMX Power Supply contains more than one live circuit. During an emergency, utility power may be disconnected at the service entrance or main electrical panel to protect emergency personnel. Power may still present at the output. To prevent the possibility of injury to service or emergency personnel, always follow this procedure to safely shutdown the power supply.

Emergency Shutdown Procedure:

- STEP 1:** Turn the battery breaker to OFF.
- STEP 2:** Unplug the AC Input Line Cord from the service entrance.



This page intentionally blank

This page intentionally blank

Power

Alpha Technologies



Alpha Technologies
3767 Alpha Way
Bellingham, WA 98226
USA
Tel: +1 360 647 2360
Fax: +1 360 671 4936
Web: www.alpha.com

Alpha Technologies Ltd.
4084 McConnell Court
Burnaby, BC, V5A 3N7
CANADA
Tel: +1 604 430 1476
Fax: +1 604 430 8908

Alpha Technologies
Europe Ltd.
Twyford House
Thorley
Bishop's Stortford
Hertfordshire
CM22 7PA
UNITED KINGDOM
Tel: +44 1279 501110
Fax: +44 1279 659870

Alpha Technologies GmbH
Hansastrasse 8
D-91126 Schwabach
GERMANY
Tel: +49 9122 79889 0
Fax: +49 9122 79889 21

Alphatec, Ltd
P.O. Box 56468
Limassol, Cyprus
CYPRUS
Tel: +357 25 375675
Fax: +357 25 359595

AlphaTEK ooo
Khokhlovskiy Pereulok 16
Stroenie 1, Office 403
109028 Moscow
RUSSIA
Tel: +7 495 916 1854
Fax: +7 495 916 1349

Alphatec Baltics
S. Konarskio G. 48
Vilnius 2009
LITHUANIA
Tel: +370 5 213 8822
Fax: +370 5 213 7799

Alpha Technologies
9 impasse Sans Souci
92140 Clamart France
FRANCE
Tel: +33 1 41 90 07 07
Fax: +33 1 41 90 93 12